

Solar power & basic IC projects

60c ■ DEC. 1967

# Radio-Electronics

TELEVISION • SERVICING • HIGH FIDELITY

A  
GERNSBACK  
PUBLICATION

**BUILD**

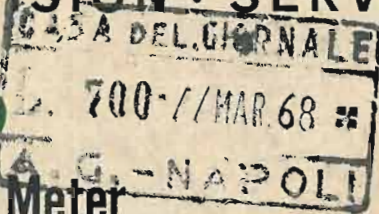

Flutter Meter  
Transmitter Monitor  
Hi-Intensity Lamp

**SPECIAL FEATURE**  
Career Opportunities  
Your future in electronics

**SERVICE**

TV Vertical Sweep  
Rotary Stepping Switches

Stereo Tape Recorder Syncs  
Slide Projector Automatically

(See page 32)



**WORLD'S LARGEST SELLING  
AND WORLD'S NEWEST**

**Hand Size V-O-M's**

**TRIPLET**



**MODEL 310**  
World's Largest Selling  
Volt-Ohm-Milliammeter

**MODEL 310-C**  
World's Newest  
Volt-Ohm-Milliammeter

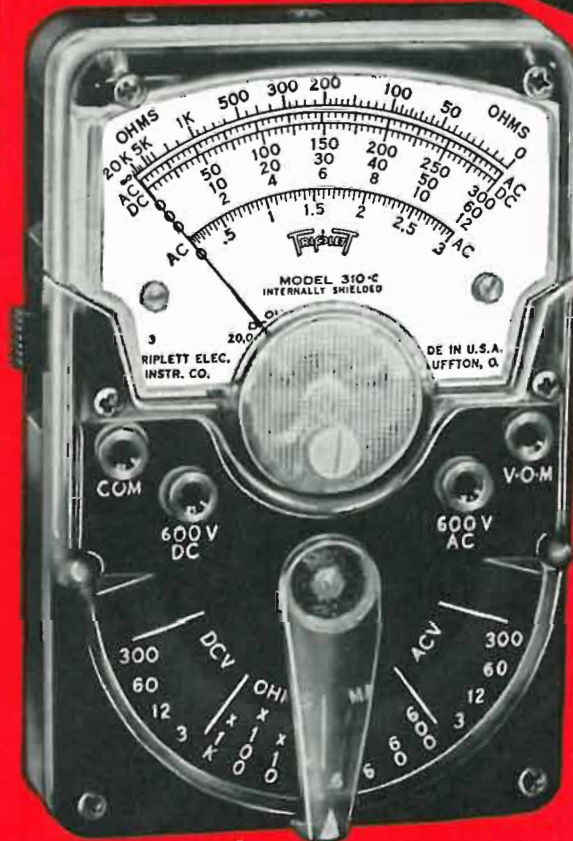

**BOTH TESTERS  
SHOWN  
ACTUAL SIZE**

- 1** HAND SIZE AND LIGHTWEIGHT, but with the features of full-size V-O-M's.
- 2** 20,000 OHMS PER VOLT DC; 5,000 AC (310)—15,000 AC (310-C).
- 3** EXCLUSIVE SINGLE SELECTOR SWITCH speeds circuit and range settings. The first miniature V-O-M's with this exclusive feature for quick, fool-proof selection of all ranges.

SELF-SHIELDED Bar-Ring instrument; permits checking in strong magnetic fields. FITTING INTERCHANGEABLE test prod tip into top of tester makes it the common probe, thereby freeing one hand. UNBREAKABLE plastic meter window. BANANA-TYPE JACKS—positive connection and long life.

Model 310—\$42.00      Model 310-C—\$53.00      Model 369 Leather Case—\$4.00

ALL PRICES ARE SUGGESTED U.S.A. USER NET, SUBJECT TO CHANGE

**THE TRIPLET ELECTRICAL INSTRUMENT COMPANY, BLUFFTON, OHIO**

### 310-C PLUS FEATURES

1. Fully enclosed lever range switch
2. 15,000 Ohms per volt AC (20,000 O/V DC same as 310)
3. Reversing switch for DC measurements

### MODELS 100 AND 100-C

Comprehensive test sets. Model 100 includes: Model 310 V-O-M, Model 10 Clamp-on Ammeter Adapter; Model 101 Line Separator; Model 379 Leather Case; Model 311 leads. (\$78.00 Value Separate Unit Purchase Price.)

MODEL 100—U.S.A. User Net..\$74.00  
MODEL 100-C—  
Same as above, but  
with Model 310-C,  
Net.....\$84.00



**USES UNLIMITED: FIELD ENGINEERS • ELECTRICAL, RADIO, TV, AND APPLIANCE SERVICEMEN • ELECTRICAL CONTRACTORS • FACTORY MAINTENANCE MEN • ELECTRONIC TECHNICIANS • HOME OWNERS, HOBBYISTS**  
THE WORLD'S MOST COMPLETE LINE OF V-O-M's • AVAILABLE FROM YOUR TRIPLET DISTRIBUTOR'S STOCK

# What Does electronics Mean To You?

As you know, this is the "electronics age." And electronics technology is changing so rapidly that the average technician's store of knowledge is highly obsolescent. He must get more education or get out of this field! He must understand *fundamental principles and concepts*. Only on the basis of such understanding can he easily adapt to the swift changes now occurring.

The technician who knows only the "how" of electronics is left behind again and again by new designs and techniques. But by comprehending the "why," he remains an *expert* — well paid and respected in his field.

## Where Do YOU Go From Here?

Are you standing still? If you mean to be an electronicsman, get with it. You must prepare for the swift changes which are now occurring. Grantham strong-foundation training in electronics engineering technology leads to non-obsolescent skills — to skills which are based more on reasoning than on merely doing.

## Earn Your FCC License and Associate Degree

The entire Grantham educational program is *five semesters* in length. Semesters 1, 2, and 4 are offered by correspondence. In the first two semesters (by correspondence\*) you earn your first class FCC license and radar endorsement. But you don't have to stop there.

In today's world of electronics employment, an FCC license is important and worthwhile, but it's not enough! Without further education, you can't make it to the top. Train with the School which gives associate-degree credits for your license training, and offers you the opportunity to advance beyond the FCC license level to a college degree in electronics. The entire curriculum is as follows:

**Semester 1** — Basic Electronics Technology  
(by correspondence, \* 80 lessons)

**Semester 2** — Communications Circuits & Systems  
(by correspondence, \* 80 lessons)

At this point you are prepared to pass the FCC examination for your first class radiotelephone license.

**Semester 3** — Electronics Laboratory  
(in residence, or credit given for practical experience)

**Semester 4** — Advanced Technical Mathematics  
(by correspondence, 80 lessons)

**Semester 5** — Circuit Design, & Computer Technology  
(in resident classes)

Upon completion of the five-semester curriculum, you are awarded the Degree of *Associate in Science in Electronics Engineering*.

## Grantham School of Electronics

1505 N. Western Ave.      818 18th Street, N.W.  
Hollywood, Calif. 90027    or    Washington, D.C. 20006

Telephone:  
(213) 469-7878

Telephone:  
(202) 298-7460

## Credit for Practical Experience

Technicians who have had extensive practical experience in electronics may receive credit in advance for Semester 3, thus reducing the *resident-instruction* requirement for the associate degree to one semester — Semester 5. Also, credit for Semester 1 may be obtained by the passing of an advanced-standing examination. Details concerning these credits are found in our current School Bulletin. Ask for your free copy.

## Accreditation, and G.I. Bill Approval

Grantham School of Electronics is *accredited* by the National Home Study Council, and is *approved* under the G.I. Bill. For seventeen years, Grantham has been preparing men for successful electronics careers.

## It's Your Move

The move you make today can shape your future. Begin now with a step in the right direction — Step #1 — and then follow through with Steps #2, #3, and #4.

**Step #1** is a simple request for full information on the Grantham Associate Degree Program in Electronics. You take this step by filling out and mailing the coupon shown below. We'll send full information by return *mail*. No salesman will call.

**Step #2** is earning your FCC first class radiotelephone LICENSE and radar endorsement. You complete this step in the first two semesters of the Grantham educational program.

**Step #3** is earning your ASEE DEGREE. This degree is conferred when you have earned credit for all five semesters of the Grantham curriculum.

**Step #4** is getting a better job, greater prestige, higher pay on the basis of your extensive knowledge of electronics.

It's your move! Why not begin now with Step #1.

\*Semesters 1, 2, and 3 of the Grantham electronics curriculum are available *also in resident classes* at our Washington, D.C. school — at the address shown below.

**Grantham School of Electronics**      12-67-RE  
1505 N. Western Ave., Hollywood, Calif. 90027

Please mail me free literature describing Grantham courses in electronics. I understand no salesman will call.

Name \_\_\_\_\_ Age \_\_\_\_\_

Address \_\_\_\_\_

City \_\_\_\_\_ State \_\_\_\_\_ Zip \_\_\_\_\_

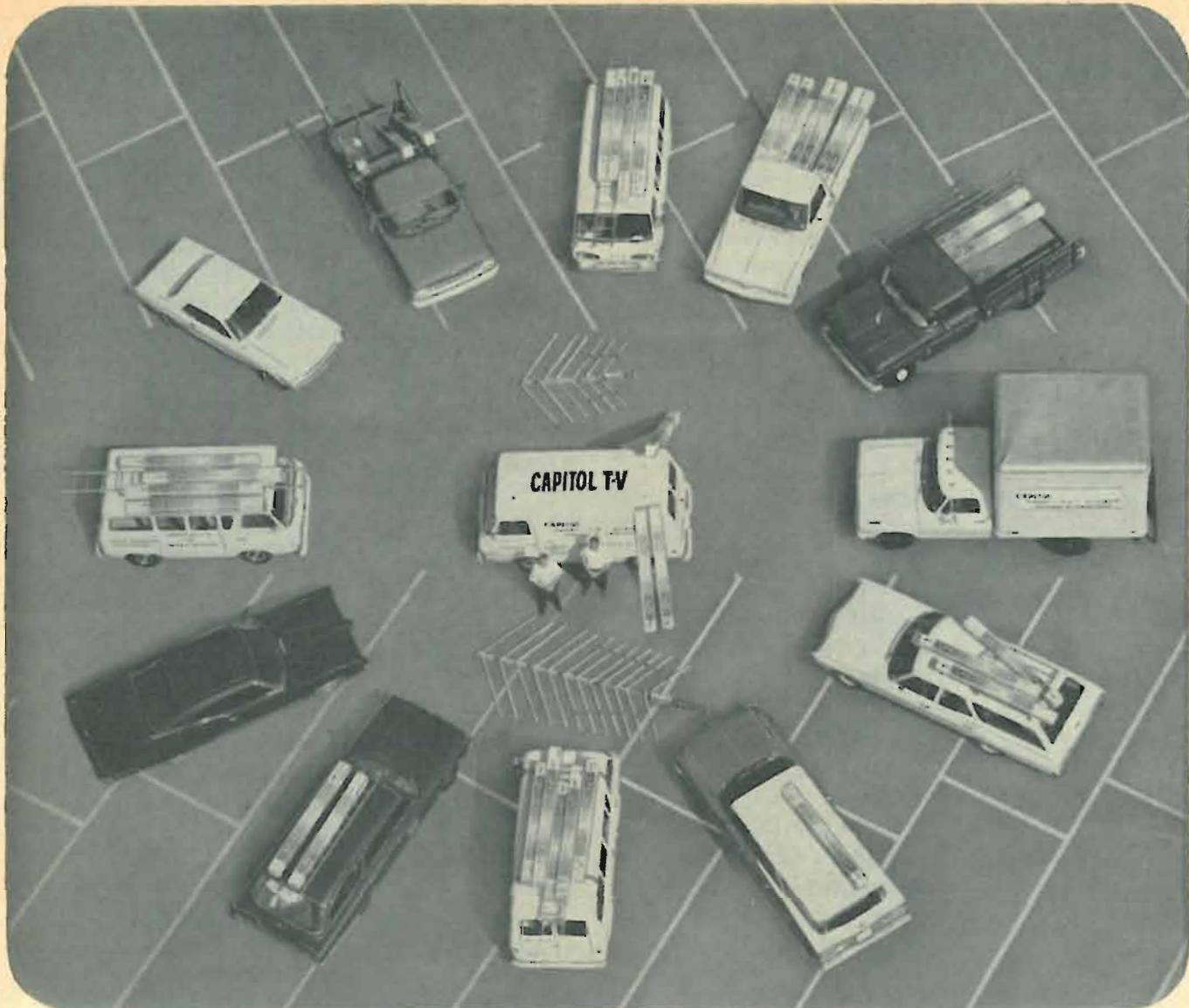

## "When you guarantee finer color pictures..."

...like we do, you *better* deliver!" says George Comer and Bob Garrison, of Capitol TV Sales and Service, Atlanta, Georgia.

"We install antennas for many dealers, retailers, chains and department stores here in the Atlanta area. They look to us to give their customers the fine color reception their customers were guaranteed when they bought their sets. We make sure we deliver the best possible color pictures by installing JFD Color Lasers.

"Before using Color Lasers, we installed VHF LPV Log Periodics. Frankly, we didn't think a combination 82-channel antenna would work so well across the VHF, UHF and FM bands. But the Color Laser is proving it to us where it counts — in happy customers and protected profits."

George Comer and Bob Garrison know from experience—like other professionals

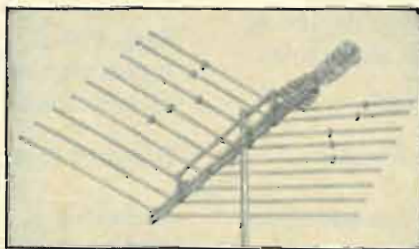

— that JFD Color Lasers come through with the superb reception people expect from a professional service company.

Only Color Lasers offer:

**BRILLIANT COLOR** — flat (frequency independent) response across each channel, free from suck-outs or roll-off. Keeps colors vivid and alive.

**PATENTED W-I-D-E BAND LOG PERIODIC DESIGN** — the most efficient ever developed — provides higher gain, better

signal-to-noise ratios, needle-sharp directivity. Eleven patents cover its revolutionary space-age design.

**MORE DRIVEN ELEMENTS.** Harmonically resonant capacitor coupled design makes dual-function elements work on both VHF and UHF frequencies. *Entire* antenna (not just part of it as in other log periodic imitations) responds on every channel.

**LUSTROUS, ELECTRICALLY CONDUCTIVE GOLD ALODIZING** promotes signal transfer, protects against corrosion, enhances appearance.

*The Best Antenna for Color TV is The Color Laser by*

# JFD®

*Now at your JFD distributor!*

**JFD ELECTRONICS CO.** 15th Avenue at 62nd Street, Brooklyn, N.Y. 11219

JFD International, 64-14 Woodside Ave., Woodside, N.Y. 11377 JFD Canada, Ltd., Ontario, Canada

JFD de Venezuela, S.A., Avenida Los Haticos 125-97, Maracaibo, Venezuela

LICENSED UNDER ONE OR MORE OF U.S. PATENTS 2,958,081; 2,985,879; 3,011,168; 3,108,280; 3,150,376; 3,210,767. RE. 25,740 AND ADDITIONAL PATENTS PENDING IN U.S.A. AND CANADA. PRODUCED BY JFD ELECTRONICS CO. UNDER EXCLUSIVE LICENSE FROM THE UNIVERSITY OF ILLINOIS FOUNDATION. LICENSED UNDER ONE OR MORE OF U.S. PATENTS 2,955,287 AND 3,015,821 AND ADDITIONAL PATENTS PENDING.

Circle 9 on reader's service card

# Radio-Electronics

December 1967 VOL. XXXVIII No. 12  
Over 55 Years of Electronics Publishing

## CAREERS

- 38 **Your Future in Electronics** . . . . . Ray Clifton  
*Upgrade yourself . . . opportunity is knocking*
- 40 **Q & A on an Electronics Career**
- 40 **Electronic Schools Directory**
- 41 **The FCC License . . . and How to Get It** . . . . Thomas R. Haskett  
*Your ticket to exciting jobs*

## CONSTRUCTION PROJECTS

- 32 **Build a Solid-State Tape/Slide Synchronizer** . . Robert S. Havenhill  
*Let your tape recorder trigger your slide projector*
- 34 **The Solar-Powered Gamma Goat** . . . . . John Hoke  
*One way to get your youngsters interested in electronics*
- 43 **30 Basic IC Projects** . . . . . R. M. Marston  
*Useful applications for an 80-cent integrated circuit—Part 1 of a series*
- 52 **A Compact, High-Performance Flutter Meter** . . . Earl T. Hansen  
*Spot tape recorder speed variations within 0.1%*
- 56 **Build a Professional Quality Transmitter Monitor** . . . . J. P. Neil  
*Keep tabs on your CB, ham or commercial two-way rig*
- 59 **Build a Two-Way, Two-Way Lamp** . . . . . Byron G. Wels  
*Inexpensive low-cost, high-intensity light and transformer-less too*

## SERVICING

- 16 **In the Shop . . . With Jack** . . . . . Jack Darr  
*Service Clinic*
- 49 **Vertical Sweep Manual** . . . . . Homer L. Davidson  
*Ups and downs scanning problems*

## GENERAL ELECTRONICS

- 46 **Rotary Stepping Switches** . . . . . Tom Jaski  
*Part 2 of 2 parts . . . round and round it goes*
- 62 **Equipment Report: Ampex 985 Music Center**
- 67 **Equipment Report: Amphenol Millivolt Commander**

## THE DEPARTMENTS

- |                          |   |
|--------------------------|---|
| 82 Annual Index          | 88 New Semiconductors and Microcircuits |
| 6 Correspondence         | 4 News Briefs                           |
| 78 Miss-Q                | 92 Noteworthy Circuits                  |
| 78 New Antenna Equipment | 87 Technotes                            |
| 75 New Audio Equipment   | 93 Try This One                         |
| 80 New Literature        | 72 Reader's Service Page                |
| 79 New Products          |   |



p 38—BETTER JOBS AHEAD



p 34—IT RUNS ON SUNLIGHT

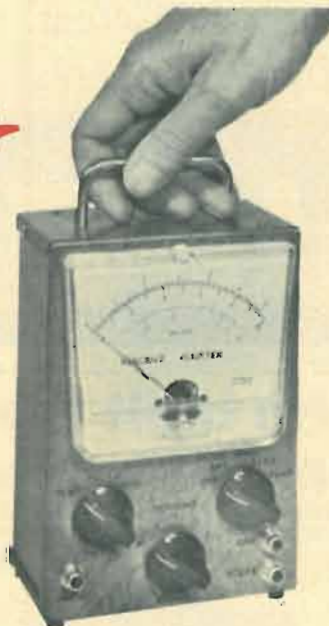

p 52—FLUTTER METER

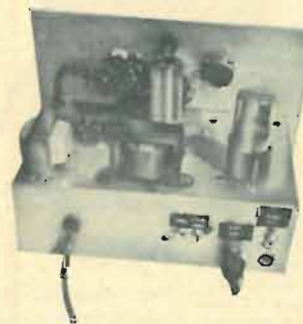

p 56—XMTR MONITOR

p 49—VERTICAL BUGS



RADIO - ELECTRONICS, DECEMBER 1967, Volume XXXVIII; No. 12, Published monthly by Gernsback Publications, Inc., at Ferry St., Concord, N. H. 03302

Editorial, Advertising, and Executive offices: 154 West 14th Street, New York, N. Y. 10011. Circulation Office, Boulder, Colo. 80302.

Second-class postage paid at Concord, N. H. Printed in U.S.A. One-year subscription rate: U. S. and possessions, Canada, \$5. Pan-American countries, \$6. Other countries, \$6.50. Single copies: 60c. © 1967, by Gernsback Publications, Inc. All rights reserved.

POSTMASTERS: Notices of undelivered copies (Form 3579) to Boulder, Colo. 80302.

## COVER FEATURE



p 32—SLIDE TRIGGER ON TAPE

Equipment shown on cover: Sony Superscope Tape recorder TC-200 and Nikkormat Autofocus Slide Projector.

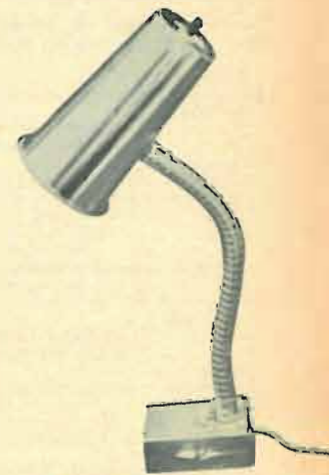

p 59—HI-INTENSITY LAMP



Member, Institute of High Fidelity. Radio-Electronics is indexed in Applied Science & Technology Index (formerly Industrial Arts Index)

The new Sony FM Stereo Tuner is highly sensitive. It pulls in the weakest stations sharply and clearly. For all its sensitivity, it is unusually insensitive. An ingenious new cadmium-sulfide CdS bandpass RF attenuator protects weak stations from being blanketed by strong signals. There's so much to recommend the ST-5000W. Double-tuning IF transformers, at all 8 stages of the IF section, reject spurious signals and noise. A 5-gang, high precision, silver-plated tuning capacitor contributes to excellent sensitivity. A

tuning meter pinpoints the center of any channel visually. Another meter helps adjust the antenna for maximum signal pick-up. A stereo switch automatically selects the correct mode—stereo or mono. An indicator light spots stereo programs. An adjustable muting switch suppresses interstation noise. Tune in the ST-5000W at your hi-fi dealer. Suggested list \$399.50. Sony Corp. of America, Dept. H., 47-47 Van Dam St., Long Island City, New York 11101

**SONY**

## Can a sensitive FM Stereo Tuner also be insensitive? Tune in and find out.

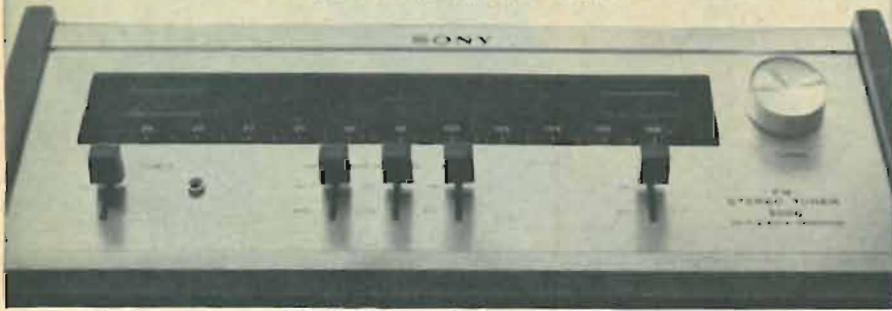

Circle 10 on reader's service card

## People who built their own Schober Organs wrote this ad

Here's what they say about the pleasure of assembling the Schober Electronic Organ from kits . . . and enjoying the magnificent sound of an instrument they've created in their spare time.

**Building was fun**  
"Building it was at least as much fun as playing it!"  
Mr. Lester F. Schwartz,  
Somerset, N. J.

**So proud I could pop**  
"I've done over 90 per cent of the work on this organ myself—and I'm so proud I could about pop!"  
Mrs. V. P. Allbert,  
Topeka, Kansas

**Nothing as fine under \$5,000**  
". . . I could not find any organ that sounded as fine as the Schober under \$5,000."  
Mr. Jerome J. Fraenkel,  
Franklin Square, N. Y.

**Proud to own**  
"I am proud to own such a valuable instrument."  
Mr. Jean J. Juteau,  
Montreal, Canada



The NEW Schober THEATRE ORGAN—  
one of four models available

**Most cherished possession**  
"My spinet has become the most cherished possession in our home—fabulous, indeed."  
Mr. Frank J. Marion,  
North Bergen, N. J.

**Tremendous sound**  
"The sound is conservatively, tremendous."  
Mr. Paul DeForest Wren,  
Westbrook, Conn.

**Unbelievably easy to build**  
"When we ran out of instruction, the organ was finished . . . To me it was unbelievable!"  
Mr. Ted Sowinski,  
Chicago, Illinois

Thousands of music lovers in every walk of life—from teen-agers to grandmothers, from people who are "all thumbs" to electronic engineers—have enjoyed the pleasure of assembling, playing and hearing the magnificent sound of the Schober organ. Whether you favor Bach or Bop, there is a Schober organ that gives you full range of expressional and tonal quality—so like a fine pipe organ that many listeners can't tell the difference. You can build a Schober organ for as little as \$645. And—even if you've never played a note before—Schober's self-teaching courses give you immediate musical results.

Over 50% of Schober Organ owners never handled an electronic job before and didn't play a note, yet assembled some of the best organs ever designed and get a daily thrill from making their own music. Isn't it time for you to take this cost-saving road to greater musical

pleasure—and enjoy the satisfaction of doing it yourself?

**Free Information and Demonstration Recording**  
Send today for your free copy of Schober's 16-page, full color booklet, plus 7" free recording.

The Schober Organ Corp., Dept. RE-52  
43 West 61st Street, New York, N. Y. 10023

- Please send me Schober Organ Catalog and free 7-inch "sample" record.
- Enclosed please find \$1.00 for 12-inch L.P. record of Schober Organ music.

NAME \_\_\_\_\_  
ADDRESS \_\_\_\_\_  
CITY \_\_\_\_\_ STATE \_\_\_\_\_ ZIP \_\_\_\_\_

Circle 11 on reader's service card

# NEWS BRIEFS

## TRANSISTORS— THREE FOR A PENNY?

That's the prediction of a major semiconductor manufacturer. By 1970, according to Philco-Ford's Microelectronics Division, the cost-per-transistor will be a few tenths of a cent. By 1975, cost should be down to a few hundredths of a cent.

The reason is LSI, or large-scale integration. Now being produced is an IC package containing 10 IC's, each of which contains 1,200 transistors fabricated at the same time. The package total is 12,000 transistors in a space only slightly larger than an ordinary IC.

## NEW LIGHT GENERATOR AND DETECTOR

An *acoustic domain*—a concentration of crystal lattice vibrations moving at the speed of sound—has been used by Bell Telephone Laboratories to generate light from an array of pn junctions (see sketch).

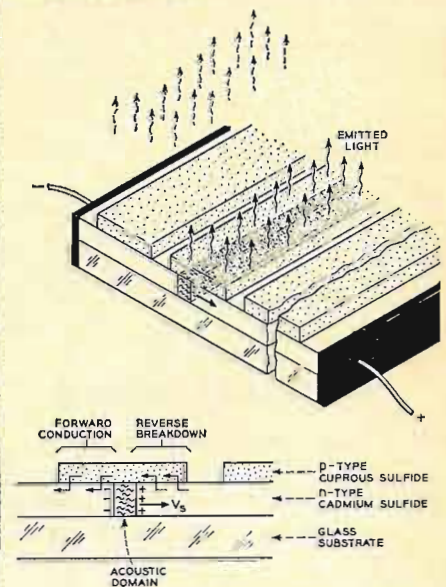

When excited by an external electric field, SALS (for Solid-state Acousto-electric Light Scanner) emits light. Unlike other light-emitting solid-state devices, each SALS pn junction need not be connected in the circuit; the acoustic domains travel down the rows, exciting each junction in turn.

Depending on junction breakdown voltage and applied voltage, SALS may also be used as a light detector.

**R-E**

# Amazing "power tool" for electronics men

Still working electronics problems with that old-fashioned manual tool, the pencil? You're not alone. And that's kind of a shame in this wonderful age when power tools have speeded up so many manual jobs. Now here is an amazing "power tool" that zips through electronic calculations like a power saw through soft pine. The CIE Electronics Slide Rule. It has a special scale that works reactance problems in seconds. And another scale that does the same for resonance problems. Plus two more scales that tell exactly where the decimal points go.

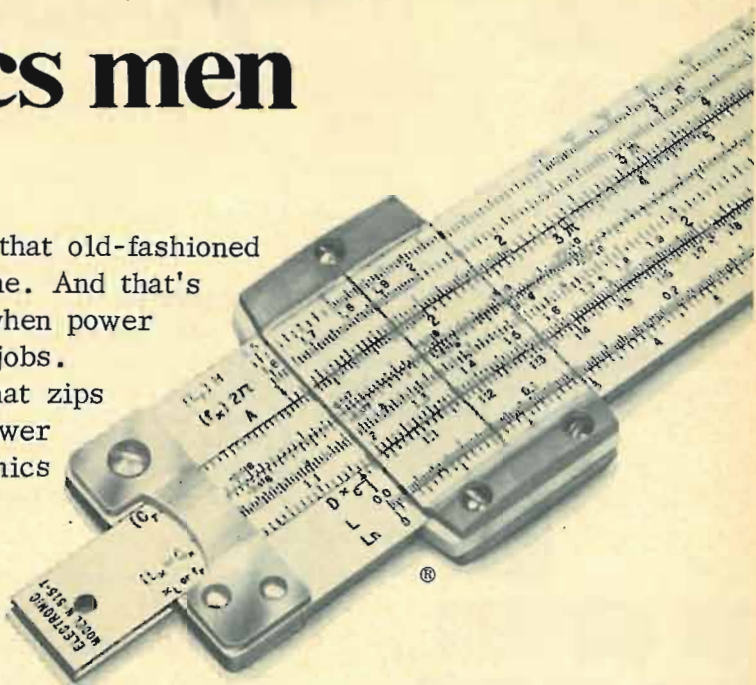

No guesswork. No paperwork. No rough calculations. You get an accurate answer in 20 seconds or less.

It also does the things ordinary slide rules do. Like multiply, divide and extract square roots in one setting. Or find reciprocals for resistance formulas, logarithms for decibel formulas, and trigonometric functions for AC circuitry formulas. And work the formulas in seconds.

The Electronics Slide Rule is easy to use even if you've never worked a slide rule before. It was developed by CIE, one of America's leading electronics schools. And it comes with a 4-lesson course that turns you into an expert. Not just an instruction manual, but a real Instruction Course. With assignments you may send in for grading by our instructors. And when you finish, a Certificate of Achievement that "tells the world" you're an electronics slide rule expert.

The slide rule and course are sold together -- for about half what we think they're worth. It's our way of getting acquainted with men around the country who want to get ahead in electronics.

Mail the coupon for FREE booklet describing this Electronics Slide Rule. Or write to Cleveland Institute of Electronics, Dept. RE-147, 1776 E. 17th Street, Cleveland, Ohio 44114. No charge or obligation.

**GET BOTH FREE!**

POCKET ELECTRONICS DATA GUIDE

How to Solve Electronics Problems in Seconds

With new Electronics Slide Rule and Instruction Course

**SEND COUPON TODAY ->**

**CIE** **Cleveland Institute of Electronics**  
1776 East 17th Street, Cleveland Ohio 44114

Please send me without charge or obligation your FREE booklet, "How To Solve Electronics Problems In Seconds," describing the CIE Electronics Slide Rule and Instruction Course.

Name \_\_\_\_\_ (please print)

Address \_\_\_\_\_

City \_\_\_\_\_ State \_\_\_\_\_ Zip \_\_\_\_\_

Also free if you act now—our famous shirt-pocket Electronics Data Guide with useful formulas, conversion tables, color codes, and more.

Accredited Member National Home Study Council • A Leader in Electronics Training... Since 1934

RE-147

Circle 12 on reader's service card

# Impedance mismatch problems?

When most voice coil impedances were either 3.2 ohms or 8 ohms, speaker replacement was relatively simple. Then came transistor sets, and equip-

ment without output transformers, and now voice coil impedances range all over the map.

It's important to remember that a mismatched impedance in a speaker replacement will almost surely create problems... from a loss of volume to a blown transistor.

# Quam... and only Quam... helps you avoid these problems these three ways:

**1. WIDE CHOICE**—As Photofacts/Counterfactors participants, we know in advance what voice coil impedance the new equipment will require, so we generally have the right speaker in our comprehensive line when you need it.

**2. VERSATILE SPEAKERS**—Quam multi-tap speakers offer a choice of impedances in a single unit. Available in all the sizes you need for automotive replacement, Quam multi-taps handle 10, 20, or 40 ohm applications.

**3. SPECIAL SERVICE**—Just in case you run across an oddball, we offer this convenient exclusive: any Quam speaker can be supplied with any voice coil impedance, only \$1.00 extra, list price.



**QUAM**

THE QUALITY LINE  
FOR EVERY SPEAKER NEED

**QUAM-NICHOLS COMPANY**

234 East Marquette Road • Chicago, Illinois 60637

Circle 13 on reader's service card

# Correspondence

## INSTRUCTIVE AND ENJOYABLE

Why not more of your articles on "Learn Color the Programed Way". It was very instructive and enjoyable to read. And for Jack Darr, once again, he is very helpful with his articles in "Service Clinic".

ANTHONY POLLIFIONE  
Fairview, N.J.

More of these articles coming up, Tony.

## RADIATION AND CROWD CONTROL

Do private and government broadcasting stations control crowds and riots by various and varying pulsations? I am interested in city planning and would like to know if the street lighting and ground pulsations of a city affect outer space radiation.

OTIS H. McLAUGHLIN, JR.  
Oklahoma City, Okla.

*Don't know about street lighting and ground pulsations, but the broadcast stations use propaganda and advertising to move crowds. However, it's an idea; could try modulating the lights and the earth's tremblings.*

## TAPE/SLIDE SYNCHRONIZER

In your June, 1967 issue there is an article by Lyman E. Greenlee describing a voice-controlled sound relay. I would like to control a slide projector from a specific sound recorded on a tape. Do you suppose Mr. Greenlee could write another article showing how this could be done?

ROBERT C. GAYHART  
Boulder, Colo.

*Bob, you must have been doing some mindreading . . . see page 32.*

## INFO ON HYPERBOLIC HORNS WANTED

I am taking your suggestion and writing to tell you what I would like to see in R-E. I liked Novak's article on speakers and enclosures ("Baffle: Speaker-Air Interface," June 1967). How about having him write an arti-

(continued on page 12)

# Radio-Electronics

154 WEST 14TH STREET  
NEW YORK, N. Y. 10011

HUGO GERNSBACK (1884-1967)

editor-in-chief and founder

M. HARVEY GERNSBACK, publisher

ROBERT CORNELL, editor

Robert F. Scott, W2PWG, senior editor

Thomas R. Haskett, managing editor

Jack Darr, service editor

Peter E. Sutherland, audio editor

I. Queen, editorial associate

Matthew Mandl, contributing editor

Linda Albers, assistant to editor

Wm. Lyon McLaughlin,

technical illustration director

Bruce Ward, production manager

Adelaide Cassity, production assistant

G. Aliquo, circulation manager

Cover by Harry Schlack

RADIO-ELECTRONICS is published by Gernsback Publications, Inc.

President: M. Harvey Gernsback

Vice President-Secretary: G. Aliquo

## ADVERTISING REPRESENTATIVES

### EAST

John J. Lamson,

RADIO-ELECTRONICS, 154 West 14th Street, New York, N. Y. 10011, 212-255-7755

MIDWEST/N.&S. Car., Ga., Tenn.

Robert Pattis, the Bill Pattis Co., 4761 West Touhy Ave., Lincolnwood, Ill. 60646, 312-679-1100

W. COAST/Texas/Arkansas/Oklahoma

J. E. Publishers Representative Co., 8380 Melrose Ave., Los Angeles, Calif. 90069, 213-653 5841; 420 Market St., San Francisco, Calif. 94111, 415-981-4527

### UNITED KINGDOM

Publishing & Distributing Co., Ltd., Mitre House, 177 Regent St., London W.1, England

**SUBSCRIPTION SERVICE:** Send all subscription correspondence and orders to RADIO-ELECTRONICS, Subscription Department, Boulder, Colo. 80302. For change of address, allow six weeks, furnishing both the old and new addresses and if possible enclosing label from a recent issue.

**MOVING?** Or writing about subscription? Be sure to fill out form below.

For FASTEST service on address change, missing copies, etc., attach old mailing label in first space below. Otherwise please print clearly your address as we now have it.

OLD ADDRESS (Attach old label if available)

Name .....

Address .....

City ..... State .....

Zip Code .....

### NEW ADDRESS

Name .....

Address .....

City ..... State .....

Zip Code .....

Mail to: RADIO-ELECTRONICS  
Subscription Dept. Boulder, Colo. 80302





# SEE WHY so many DeVry-trained Men Step Into Electronics Jobs the Day after Graduation!

## **EVERY GRADUATE CAN ALSO RECEIVE EMPLOYMENT HELP THROUGH HIS ENTIRE CAREER, AT NO ADDED COST**

DeVry's greatest claim to fame is the progress of its graduates. Our aim is to prepare a man so thoroughly that we can recommend him to employers . . . ready to step into a job the day after graduation. If we expect to continue to help employers, our graduates have to be good! That is why we provide top quality instruction—followed by career-long employment service at no added cost.

DeVry's educational programs are designed to prepare men 17-45 in their spare time at home or in any of our three well-equipped, modern resident schools in Chicago, Phoenix or Canada. Why not fill in and mail coupon for free facts today?

**Approved for Veterans.**

### For FREE Information

Lack of technical experience is no barrier to the man who wants to prepare for a career in ELECTRONICS. Send coupon for two FREE booklets and find out why.



Accredited Member of National Home Study Council

**DEVRY INSTITUTE OF TECHNOLOGY**  
4141 BELMONT AVENUE, CHICAGO, ILLINOIS 60641

### DEVRY INSTITUTE of TECHNOLOGY 4141 Belmont Avenue, Chicago, Ill. 60641, Dept. RE-12-X

Please give me your two free booklets, "Pocket Guide to Real Earnings," and "Electronics in Space Travel"; also include details on how to prepare for a career in Electronics. I am interested in the following opportunity fields (check one or more):

- |  |   |
|--|---|
| <input type="checkbox"/> Space & Missile Electronics | <input type="checkbox"/> Communications         |
| <input type="checkbox"/> Television and Radio        | <input type="checkbox"/> Computers              |
| <input type="checkbox"/> Microwaves                  | <input type="checkbox"/> Broadcasting           |
| <input type="checkbox"/> Radar                       | <input type="checkbox"/> Industrial Electronics |
| <input type="checkbox"/> Automation Electronics      | <input type="checkbox"/> Electronic Control     |

Name \_\_\_\_\_ Age \_\_\_\_\_

Address \_\_\_\_\_ Apt. \_\_\_\_\_

City \_\_\_\_\_ State or Province \_\_\_\_\_ Zone or Zip Code \_\_\_\_\_

Check here if you are under 16 years of age.

**HOME STUDY AND RESIDENT SCHOOL PROGRAMS  
AVAILABLE IN CANADA. SEND FOR DETAILS.**

2106

# Electronics comes alive with NRI Training Kits



# DISCOVER THE EASE AND EXCITEMENT OF TRAINING AT HOME THE NRI WAY

## New Achievement Kit—Custom Training Kits—"Bite Size" Texts

Only NRI offers you this pioneering method of simplified "3 Dimensional" home-study training in Electronics, TV/Radio and Broadcasting/Communications. It's a remarkable teaching idea unlike anything you have ever encountered, the result of more than half a century of simplifying, organizing and dramatizing learning-at-home techniques. If you are an ambitious man—regardless of your education—you can effectively learn the Electronics field of your choice the NRI way.

NRI has *simplified* Electronics by producing "bite size" lesson texts averaging only 40 pages each. Dozens of illustrations open wide a picture window through which you'll see and understand practical uses of Electronics. You start out with NRI's exclusive Achievement Kit, containing everything you need to get started fast. (Illustrated at right.)

NRI has *organized* Electronics training to take you step-by-step from the first stages into more intriguing areas. Once you know the fundamentals thoroughly, it's easy to grasp more advanced theory and techniques. You move with confidence and enthusiasm into a new adventure filled with the excitement of discovery.

NRI has *dramatized* Electronics through the careful development of special training equipment that is *programmed* into your training systematically... beginning with your first group of lessons. Things you read about come alive in your hands as you build, experiment, purposely cause "problems" in circuits—and solve them. You learn to use test equipment, to build radios and TV sets, transmitter, or computer circuits. It's the priceless "third dimension" in NRI training... practical experience.



## YOU GET MORE FOR YOUR MONEY FROM NRI

Mail postage-free card now for your free NRI catalog. Then, compare. You'll find—as have thousands of others—NRI training can't be beat. Read about the new Achievement Kit sent the day you enroll; about "bite-size" texts and custom designed training equipment. See why NRI gives you more value. Whatever your reason for wanting more knowledge of Electronics, NRI has an instruction plan for you. Choose from major programs in TV/Radio Servicing, Industrial Electronics and Complete Communications. Or select from special courses to meet specific needs. Check the course of interest to you on postage-free card and mail today for free NRI catalog. No salesman will call. NATIONAL RADIO INSTITUTE, Electronics Div., Washington, D.C. 20016.

Available Under

**NEW  
GI BILL**

If you served since January 31, 1955, or are in service, check GI line in postage-free card.

More than 50 years of leadership  
in Electronics Training



## Career? Part-Time Earnings? Hobby? Choose From 12 Training Plans

**1. TELEVISION-RADIO SERVICING** — Learn to fix all TV sets, including Color. Includes your choice of NRI Color Kit or 19" black-white TV Kit. Also covers radios, stereo hi-fi, etc. Profitable field spare or full-time.

**2. INDUSTRIAL-MILITARY ELECTRONICS** — Basics to computers. Starts with fundamentals, covers servos, telemetry, multiplexing, phase circuitry, other subjects.

**3. COMPLETE COMMUNICATIONS\*** — Operation, service, maintenance of AM, FM and TV broadcasting stations. Also covers marine, aviation, mobile radio, facsimile, radar, microwave.

**4. FCC LICENSE\*** — Prepares you for 1st Class FCC License exams. Begin with fundamentals, advance to required subjects in equipment and procedures.

**5. MATH FOR ELECTRONICS** — Brief course for engineers, technicians seeking quick review of essential math: basic arithmetic, short-cut formulas, digital systems, etc.

**6. BASIC ELECTRONICS** — For anyone wanting a basic understanding of Radio-TV Electronics terminology and components, and a better understanding of the field.

**7. ELECTRONICS FOR AUTOMATION** — Not for beginners. Covers process control, ultrasonics, telemetering and remote control, electromechanical measurements, other subjects.

**8. AVIATION COMMUNICATIONS\*** — Prepares you to install, maintain, service aircraft in-flight and landing systems. Earn your FCC License with Radar Endorsement.

**9. MARINE COMMUNICATIONS\*** — Covers electronic equipment used on commercial ships, pleasure boats. Prepares for FCC License with Radar Endorsement.

**10. MOBILE COMMUNICATIONS\*** — Learn to install, maintain mobile transmitters and receivers. Prepares for FCC License exams.

**11. ELECTRICAL APPLIANCE REPAIR** — Learn to repair all appliances, including air conditioning, refrigeration, small gas engines. Leads to profitable part or full-time business.

**12. ELECTRONICS FOR PRINTERS** — Operation and maintenance of Electronic equipment used in graphic arts industry. From basics to computer circuits. Approved by major manufacturers.

\* You must pass your FCC License exams (any Communications course) or NRI refunds in full the tuition you have paid.

# Reward

for the recovery of each of these shunt regulator tubes

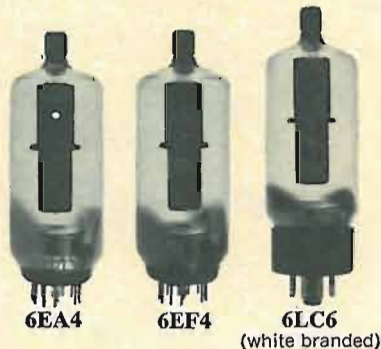

General Electric has discovered that certain of its large screen color TV sets containing these high voltage regulator tubes could emit soft X-radiation in excess of desirable levels.

Almost all of the sets which might have this potential X-ray emission have been found and modified with a new regulator tube specially designed for the purpose. We are now conducting a nationwide search for the remaining obsolete regulator tubes.

We are looking for these tubes in two ways. **Those in use** in any model General Electric color television set. **And new tubes in cartons**, on shop shelves, in trucks and kits.

Now here's how you can help us and pick up your reward.

**First, look for the above tube types of any brand in every large screen GE color set you service.** If you find one, remove it and return it to this address:

General Electric Product Service Section  
Northern Concourse Building  
North Syracuse, New York 13212

For every one you turn in, you will receive a check for \$5.00 plus a new replacement tube at no extra charge. To qualify, you need only to provide the customer's name and address and the model and serial number of the TV set serviced.

**Second, should you have unused tubes bearing these numbers in your shop or truck, send them to the following address,** and you will receive a check in the amount of 50% of list price (plus transportation expense) for each and every tube returned:

General Electric Company  
Building #12, Old Hartford Road  
P.O. Box 1008  
Owensboro, Kentucky 42301

Remember, every used tube will get you \$5.00 when mailed to Syracuse. And every new, cartoned tube when mailed to Owensboro will bring you a check worth 50% of the list price.

If you haven't seen it, we recommend you ask your GE Distributor for a copy of GE's recent "Service Talk" on X-ray precautions in servicing color TV receivers.

GENERAL  ELECTRIC

## CORRESPONDENCE continued

cle on hyperbolic horns, both bass and high frequency, including nomograms to calculate the necessary parameters since the math is so complicated.

ARTHUR GONTY, M.D.  
Menominee, Mich.

## SUBMINIATURE INTEGRATED ANTENNA

In News Briefs (July 1967), you mentioned the Subminiature Integrated Antenna developed from the use of high-gain rf transistors, under an Air Force program. Can you provide me with information to build one of these antennas at home?

WILLIAM G. RINGEL  
Indianapolis, Ind.

I am very much interested in the Subminiature Integrated Antenna concept, and would like to see more on this subject as it becomes available.

DAVID B. GIBSON  
Dade City, Fla.

I would like more detailed information on S.I.A. antennas or possibly a schematic diagram.

ANDREW USIS  
Cleveland Heights, Ohio

*One article on how to make an S. I. Antenna is scheduled to appear in the February 1968 issue, if we can get the antenna to work.*

## R-E IN VIETNAM

I want to take this opportunity to thank you for your wonderful Reader's Service. We really appreciate a great magazine like yours over here where it's so hard to get information and literature, so thanks again.

PFC RAYMOND R. SAKSA  
3rd Marine Division  
Vietnam

## REMINDER BETTER ON TAIL LIGHTS

The "Parking Light: Brake Reminder" described in Noteworthy Circuits (April 1967) will work with either parking lights or headlights if the buzzer is connected to the tail lights rather than the parking lights.

WILLIAM R. SPEAKMAN  
Reading, Pa.

## WANTS FAIRCHILD'S $\mu$ L914

I would like to build the Audio Tone-Burst Generator (July 1967) described by Dr. De Sa. However, I have not been able to locate the Fair-

**NEW!**  
**MASTER COURSE**  
**IN COLOR TV...**

## WITH NTS COLOR KITS

Big 25" Color TV kits included in new Master Color TV Home Study program. Learn Color TV; keep the new 25" color TV receiver you build with exciting kits we send you. 10 million homes in this country will have color TV by the end of 1967. This industry needs technicians as never before, and NTS-trained men can move quickly into the big money.

### COLOR TV SERVICING BRINGS HIGH PROFITS

New color sets need careful installation, precision tuning and skilled servicing. NTS home training can put you in this profit picture—prepare you for big pay, security, or start a business of your own.

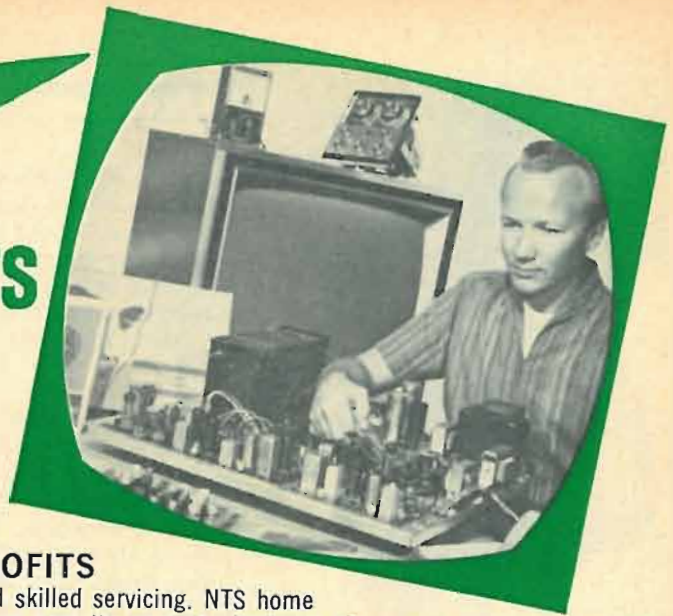

## LIFT OFF...TO A "SPACE AGE" CAREER IN ELECTRONICS

This is the "space age". It offers new opportunities in communications, industrial electronics, computer technology, and many others. Automation has increased the need for skilled electronics technicians in thousands of manufacturing plants. Only the well trained man makes it big. Industry wants and demands this kind of man... the NTS man. Pick your field. Let an NTS Project Method Program help you toward a well-paid career in Electronics wherever you travel.

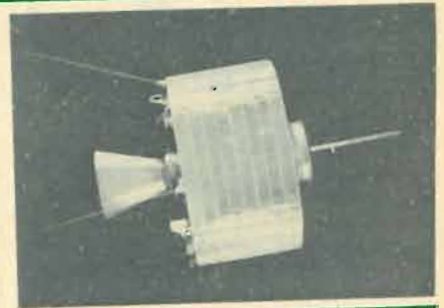

### NEW CAREER KIT... FAST, EASY START TO NTS HOME TRAINING

The exclusive Project Method Career Kit helps you move quickly into your training program. Earn while you learn as you progress with your shop-tested Project Method lessons and kits.

Send for the New illustrated NTS Color Catalog. It shows the equipment and kits you work with and keep. Describes in detail the advantages of NTS Project Method Home Training. Tells you everything you need to know about starting your career in electronics.



#### HIGH SCHOOL AT HOME

National offers accredited high school programs. Take only subjects you need. Study at your own pace. Everything included at one low tuition. Check special High-School box in coupon for full information & FREE catalog.

#### CLASSROOM TRAINING AT LOS ANGELES

You can take Classroom Training at Los Angeles in Sunny Southern California. NTS occupies a city block with over a million dollars in facilities devoted exclusively to technical training.

MAIL REPLY CARD OR  
 COUPON FOR NEW, FREE  
 COLOR CATALOG AND  
 SAMPLE LESSON.



## NATIONAL TECHNICAL SCHOOLS

World Wide Training Since 1905  
 4000 S. Figueroa St., Los Angeles, Calif. 90037  
 You enroll by mail

We have no salesmen: This means lower tuition for you.  
 Accredited Member National Home Study Council. Accredited  
 Member: National Association of Trade & Technical Schools

## NATIONAL TECHNICAL SCHOOLS

4000 S. Figueroa St., Los Angeles, California 90037

APPROVED  
 FOR  
 VETERANS



Please rush Free Color Catalog and Sample Lesson, plus detailed information on field checked below. No obligation.

Dept. 206-127

- MASTER COURSE IN COLOR TV SERVICING
- COLOR TV SERVICING
- MASTER COURSE IN TV & RADIO SERVICING
- PRACTICAL TV & RADIO SERVICING
- MASTER COURSE IN ELECTRONIC COMMUNICATIONS
- FCC LICENSE COURSE
- INDUSTRIAL & COMPUTER ELECTRONICS
- STEREO, HI FI & SOUND SYSTEMS
- BASIC ELECTRONICS     HIGH SCHOOL AT HOME

Name \_\_\_\_\_ Age \_\_\_\_\_

Address \_\_\_\_\_

City \_\_\_\_\_ State \_\_\_\_\_ Zip \_\_\_\_\_

- Check if interested in Veteran Training under new G.I. Bill.
- Check if interested ONLY in Classroom Training at Los Angeles.





**NEW  
HOLLOW  
SHAFT**

## **nutdriver set**

with Locknut/Screw  
adjusting feature

Speeds, simplifies setting of combination locknut/slotted screw adjustments on rheostats and similar controls used in a wide variety of electrical and electronic equipment.

Handle is drilled so you can run an 8" screwdriver blade right through its center and down through the hollow nutdriver shaft.

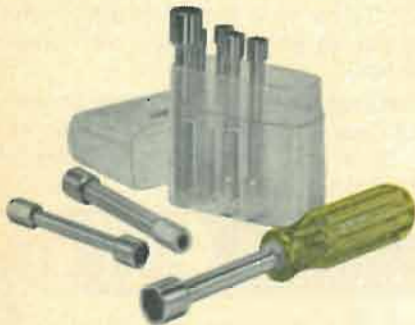

Ideal for all-around production, maintenance, and service work, this new HSC-1 Set contains eight interchangeable hollow nutdriver shafts in the most popular hex opening sizes from 3/16" thru 9/16"



Really compact! Set is small enough, light enough to carry in your hip pocket. Sturdy, see-thru, plastic carrying case doubles as a bench stand.

WRITE FOR BULLETIN N867



XCELITE, INC., 10 Bank St., Orchard Park, N. Y. 14127  
In Canada contact Charles W. Pointon, Ltd.

Circle 17 on reader's service card

### CORRESPONDENCE continued

child  $\mu$ L914 integrated circuit, at the price mentioned (under \$1.00). Would you please advise me as to where I may order this part. Incidentally, I enjoy your magazine a great deal, especially the construction articles.

LT. CHARLES D. HAMILTON, USAF  
Valdosta, Ga.

Try Powell-Florida, 2049 W. Central Blvd., Orlando, Fla., 32805; Cramer Florida, Inc., 4141 N.E. Sixth Ave., Ft. Lauderdale, Fla., 33308; Hall Mark Electronics, 7233 Lake Ellenor Drive, Orlando, Fla., 32809; Carolina Radio, 221 W. Washington St., Greenville S.C., 29601; or Schweber Electronics, 2109 Clinton Bldg., Huntsville, Ala., 35805. These are 5 stocking distributors nearest you. If you still have a problem, write directly to Fairchild Semiconductor Div., P.O. Box 1058, Mountain View, Calif., 94040. Keep in mind when ordering that many distributors have a minimum charge per order requirement and the less-than \$1.00 charge may not be available to you if your order is too small.

### MANUFACTURERS AS VILLAINS?

Dear Editor:

I suppose you would not dare to tell about how the manufacturer is the serviceman's worst enemy, since he comes along with different parts just to be different. I mean minor changes not affecting quality. They should not be allowed to introduce new components unless there is at least a 5% increase in quality or performance. The electronic business should be cleaned up.

V. N. EVERT  
Moncton, N. B., Canada

*If the manufacturer is the serviceman's worst enemy, as you say, he would not make it possible for the serviceman to be in business. At the risk of oversimplification—the formula is simple; no products made and sold, no products to service. Would you believe that a manufacturer does not make a change or add more parts to his inventory than he has to? Each addition or modification costs both time and money and complicates his operation. There is no argument about the need to reduce number of parts to be inventoried, but if things were made simpler, you would have more people competing with you for your servicing business. As it stands, there is a shortage of servicemen.*

R-E

## **new Sams books**

### Microminiature Electronics

by Israel Kalish. Microminiature electronics developed for the space and missile programs is now spreading into all phases of electronics, and will soon be commonplace in entertainment, commercial, and industrial electronic equipment design. This book clearly explains microminiature basics, and will not only help the reader prepare for packaging, operating, and servicing military microminiature equipment, but also orient him in the "think small" trend in civilian equipment. The text is of the programmed type, including questions and answers to review and accelerate learning. 304 pages; \$4.95  
5½ x 8½". Order 20582, only . . . . .

### AM-FM-TV Alignment

by Robert G. Middleton. This book tells you all you need to know about the proper alignment of a-m, f-m radios and tv sets. Each section of the receiver is analyzed step by step, and the fastest, easiest methods of alignment are shown. Separate chapters are devoted to alignment of the following: a-m receivers, f-m receivers, black-and-white tv, color-tv, f-m stereo multiplex adapters; special chapter on audio-amplifier frequency-response checks. 160 pages; 5½ x 8½". Order 20602, only . . . . . \$3.50



### ABC's of Thermocouples

by John D. Lenk. This book provides much-needed information on the important but little known subject of thermocouples. Provides a basic understanding of how they work, how they are constructed, and the many ways in which they are applied. Standard types of thermocouples and their accessories are described; color coding is explained; includes full data on calibrating and methods of compensation control for use in laboratory, flight, data system, and other environments. Also covers thermocouple readouts, recorders, and controllers. 128 pages; 5½ x 8½". Order 20586, only . . . . . \$2.25

### Symfact® Guide to TV Servicing

by Howard W. Sams Engineering Staff. Explains the normal operation of a given tv circuit, and then shows exactly the waveform display, voltage, symptoms, picture-tube display, etc., that occur when any component in that circuit is faulty. This invaluable book, in eight main sections, illustrates and describes the malfunctions that occur in specific circuits and shows how to identify and overcome them. Unbelievably practical for fast troubleshooting. 160 pages; 5½ x 8½". Order 20597, only . . . . . \$2.95

### Practical Power Supply Circuits

by John Potter Shields. Provides a thorough understanding of the basic types of power supplies used in current electronic equipment. Explains the operation of various rectifier circuits—half-, full-wave, and bridge types—and describes the characteristics of gas and high vacuum tubes, as well as scr's used in these circuits. Explains the basics of filters and voltage regulators; describes solid-state voltage and current regulation. Includes semiconductor-type power supplies, converters, and inverters. Provides typical values and construction data. 112 pages; 5½ x 8½". Order 20571, only . . . . . \$2.50

These and over 300 other SAMS Books are available from your local Electronics Parts Distributor . . .



HOWARD W. SAMS & CO., INC.  
4300 WEST 82nd ST. INDIANAPOLIS, INDIANA 46286

Circle 18 on reader's service card

**EXTRA POWER**  
with  
**FINCO**  
**AMPLIFIERS**

*For perfect color TV and  
FM Stereo Reception*

**FINCO MODEL #65-4**  
Antenna Amplifier  
\$47.95 list VHF-TV  
Two-transistor Antenna  
Amplifier for 75 OHM  
Downlead, and power  
supply with built-in  
single or dual 300 ohm  
outputs. Provides 12  
dB gain in the low band  
and 14 dB gain in the  
high band.



**FINCO MODEL #65-1**  
Distribution Amplifier  
\$29.95 list 2-tube 4-  
output VHF-TV or FM  
Distribution Amplifier  
for 300 OHM Opera-  
tion, providing 8 dB  
gain at each 300 ohm  
output to feed home or  
commercial systems.

**FINCO MODEL #65-5**  
Distribution Amplifier  
\$44.95 list VHF-TV 75  
OHM Single Outlet Dis-  
tribution Amplified for  
deluxe home or com-  
mercial use to feed  
multiple sets through  
line tap offs or split-  
ters. Delivers 17 dB  
Low Band and 14 dB  
High Band.



**FINCO MODEL #65-2**  
Distribution Amplifier  
\$39.95 list 2-tube 4-  
output VHF-TV or FM  
Distribution Amplifier  
for 75 OHM CO-AX  
Operation, providing 6  
dB gain at each 75 ohm  
output to feed deluxe  
home or commercial  
systems.

**FINCO MODEL #65-6**  
Amplifiers \$79.95 list.  
VHF-TV Antenna Moun-  
ted two-transistor pre-  
amplifier with 75 OHM  
two-tube Single Output  
Distribution Post-am-  
plifier up to 30 dB gain  
for improved reception.  
Used in home or com-  
mercial installations to  
feed multiple sets.



**FINCO MODEL #65-3**  
Antenna Amplifier  
\$44.95 list New VHF-  
TV Antenna Amplifier  
and Power Supply with  
built in single or dual  
outputs to improve re-  
ception of weak signals  
in fringe areas. Pro-  
vides 12 dB gain in the  
low band and 14 dB  
gain in the high band.

**FINCO MODEL #65-7**  
FM Signal Amplifier  
\$24.95 list. One-trans-  
istor Indoor Behind-  
the-set FM amplifier  
with a passive filter in-  
put circuit to reject sig-  
nals outside the FM  
band which cause in-  
terference. Delivers 20  
dB Gain.



**Sets "COME ALIVE" with  
Brilliant Sound and Color**

A Finco high-gain, low-noise amplifier  
will bring in the sharpest **COLOR** or  
B & W TV picture and the finest sound!

**All FINCO Products are Engineered  
For Color!**



Write for Color Brochure #20-411.

**THE FINNEY COMPANY**

34 W. Interstate Street • Dept. RE • Bedford, Ohio 44146

**Rx**  
**avoid**  
**headaches**

use Sony Tape

If you've been using any of the so-called bargain tapes, chances are you should have your heads examined. The odds are good that the heads are excessively worn and you're not getting the most out of your recorder. If you want to keep "factory-fresh" sound to your recorder—and avoid future "headaches" and keep it that way—Here's the prescription—buy Sony Professional-quality Recording Tape. Sony Tape is permanently lubricated by the exclusive Lubri-Cushion process. Sony's extra-heavy Oxi-Coating won't shed or sliver and is applied so evenly that recordings made on Sony Tape are not subject to sound dropouts. Sony Tape captures and reproduces the strength and delicacy of every sound—over and over again. There's a bonus, too, with every 5" and 7" reel of Sony Tape—a pair of Sony-exclusive "Easy Threader" tabs to make tape threading the easiest ever. And Sony reels are a sturdier, heavier gauge plastic for protection against possible warping. It's just what the "Doctor" ordered and yours for just pennies more than "bargain" tape.

**SONY** **SUPERSCOPE**

SUN VALLEY, CALIFORNIA • 91352

Circle 20 on reader's service card

## In the Shop . . . With Jack

By JACK DARR

ONE OF THE WORST PROBLEMS IN A TV is the flyback that runs hot with no apparent cause—no shorts, yoke good, and so on. It just runs hot! The set usually makes a pretty good picture: Voltages are off just enough to be obvious, and the cathode current of the horizontal output amplifier (tube or transistor) will be too high. (The energy's got to come from somewhere, to heat the flyback, and this is it.

All right now—why? Well, let's look at the basic characteristics of all flyback circuits, especially the amplifier itself. It's a pulsed stage. Although the tube or transistor used will have a rating of maybe 15 watts, the actual power dissipated during conduction can run as high as 500 watts!

The reason the stage can get away with this massive overload is simple—it goes on only for a few microseconds. Then, the poor thing cools off for quite a while, comparatively speaking, until the next pulse comes along. You can see that *conduction time* is a key factor in how much power the tube or transistor has to dissipate. Another factor is the output load (the flyback transformer).

Now, we're getting near the key point—the *shape* of the driving pulse voltage. Fig. 1-a shows a normal tube pulse, and Fig. 1-b a transistor drive pulse. Note the difference between "on time" and "off time." This is it.

Pulse shape is determined by the driving circuits and the horizontal oscillator. In transistor circuits, you'll usually find a *driver* stage; its main purpose is to get the required rectangular pulse shape, and to set the on-off time ratio.

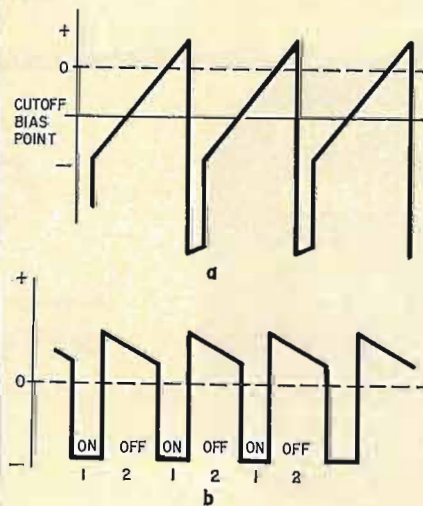

Fig. 1

This column is for your service problems—TV, radio, audio or general and industrial electronics. We answer all questions individually by mail, free of charge, and the more interesting ones will be printed here.

If you're really stuck, write us. We'll do our best to help you. Don't forget to enclose a stamped, self-addressed envelope. Write: Service Editor, Radio-Electronics, 154 West 14th Street, New York 10011.

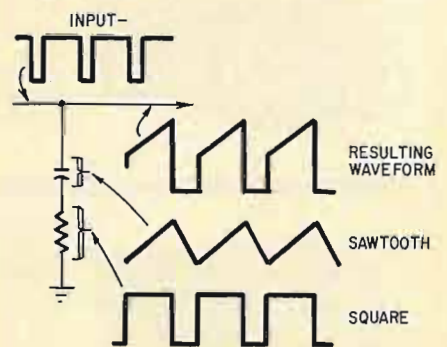

Fig. 2

The basic output of the horizontal oscillator may be a sawtooth, sine wave or even a fair square wave. None of these shapes will do, for driving the output amplifier. Transistor output stages are driven by what looks like a square wave. A close look with a scope shows that it's actually a rectangular wave, with a very precise *ratio* of on-time to off-time, usually about 1:2.

This output wave is shaped by RC networks to make the proper shape. Fig. 2 shows the basic circuit, and what it does. The output waveform is determined by the point of takeoff, and by the ratio of part values—resistance to capacitance. The proportions of the drive waveform, with respect to the cutoff point (bias) of the output amplifier, determine the on-off time of the amplifier and its total power consumption.

Sounds complicated but it isn't. Use a scope to look at the waveform and compare it to the one shown on the schematic. Then measure its p-p voltage. If there is enough distortion to cause trouble, it'll be pretty obvious. Confirm the diagnosis by taking voltage measurements, current readings and checking the output. Another way: substitute a known good drive waveform from another TV set.

If you "sub" a drive signal from  
*(continued on page 22)*





## Remember to ask—"What else needs fixing?"



That's the question to ask to add extra profit to every service call. It makes sense. Just about every customer who calls you for TV repair owns other electronic products that are excellent prospects for service. You've already invested your time getting to his home. So why not see what further service you can render?

Does it work? You bet! On a test program sponsored by Electronic Industries Association, in which Mallory is an active member, service men got 6% more profit from business they added just by asking that simple question.

Here are some tips that you can use to cash in on this idea.

Portable radios, for instance. Most homes have at least one. Ask 'em, "How about fresh batteries?" And then sell Mallory Duracell® batteries . . . best buy in long life and fade-free power. And don't forget cameras, flashlights and toys. They need batteries, too, and there's a Duracell type for every job.

Ask to check table radios . . . then listen for hum as the set warms up. Many people put up with hum because they've forgotten how well the radio sounded when new. But hum may be a sign that a filter capacitor is near the end of its life. Replace with a Mallory FP, WP, TC or MTA. Your Mallory Distributor can supply the exact size and rating you need.

How about hi-fi and stereo? Ask to turn them on, and see if you detect anything that calls for service. You can suggest adding remote speakers for a porch or family room. Be sure to include a Mallory balance control and remote volume controls, to make the installation complete. Record changers and electronic organs are good service opportunities, too.

Try this profit-building "What else needs fixing?" idea on the next calls you make. And for the quality components that make every job sure, see your Mallory Distributor. Mallory Distributor Products Company, a division of P. R. Mallory & Co. Inc., Indianapolis, Indiana 46206.

©Duracell is a registered trademark of P. R. Mallory & Co. Inc.

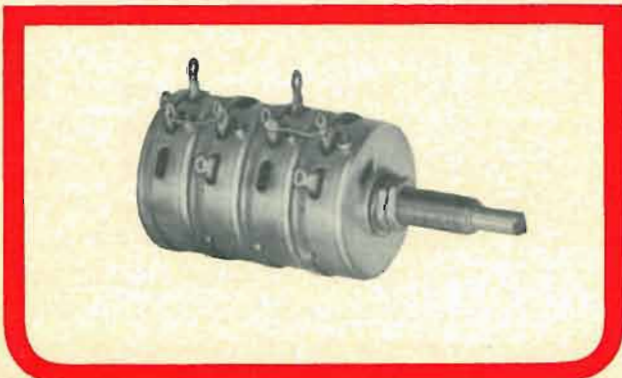

**“He’s a good worker.  
I’d promote him  
right now if he had  
more education  
in electronics.”**

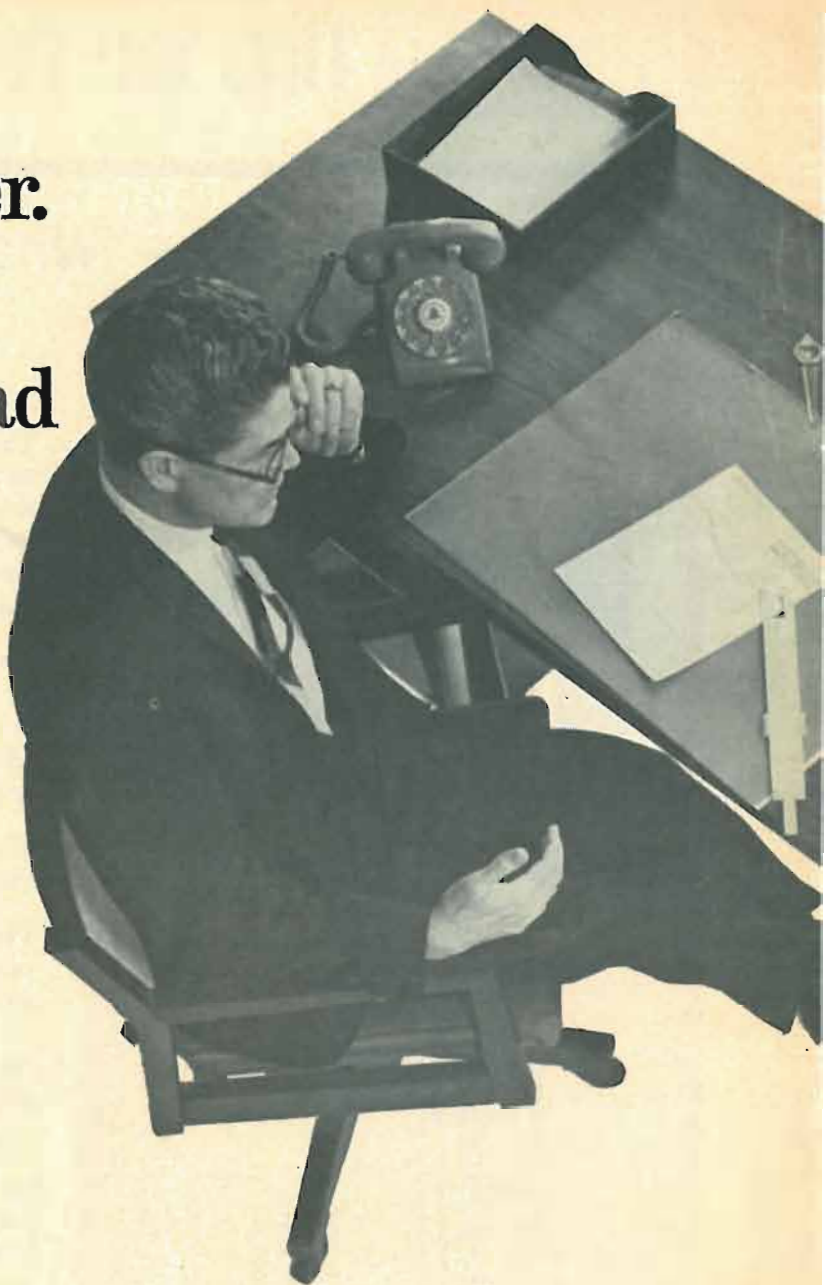

## **Could they be talking about you?**

You'll miss a lot of opportunities if you try to get along in the electronics industry without an advanced education. Many doors will be closed to you, and no amount of hard work will open them.

But you can build a rewarding career if you supplement your experience with specialized knowledge of one of the key areas of electronics. As a specialist, you will enjoy security, excellent pay, and the kind of future you want for yourself and your family.

Going back to school isn't easy for a man with a

full-time job and family obligations. But CREI Home Study Programs make it possible for you to get the additional education you need without attending classes. You study at home, at your own pace, on your own schedule. You study with the assurance that what you learn can be applied to the job immediately.

CREI Programs cover all important areas of electronics including communications, radar and sonar, even missile and spacecraft guidance. You're sure to find a program that fits your career objectives.



Founded 1927



Accredited Member  
of the National Home Study Council

You're eligible for a CREI Program if you work in electronics and have a high school education. Our FREE book gives complete information. Airmail post-paid card for your copy. If card is detached, use coupon at right or write:

CREI, Dept. 1412E  
3224 16th St., N.W.,  
Washington, D.C. 20010.



**The Capitol Radio Engineering Institute**

*A Division of McGraw-Hill, Inc.*  
**Dept. 1412E, 3224 Sixteenth Street, N.W.**  
**Washington, D.C. 20010**

Please send me FREE book describing CREI Programs. I am employed in electronics and have a high school education.

NAME \_\_\_\_\_ AGE \_\_\_\_\_

ADDRESS \_\_\_\_\_

CITY \_\_\_\_\_ STATE \_\_\_\_\_ ZIP CODE \_\_\_\_\_

EMPLOYED BY \_\_\_\_\_

TYPE OF PRESENT WORK \_\_\_\_\_  G.I. BILL

- I am interested in  Electronic Engineering Technology  
 Space Electronics  Nuclear Engineering Technology  
 Industrial Electronics for Automation  
 Computer Systems Technology

**APPROVED FOR TRAINING UNDER NEW G.I. BILL**

NEW FROM INJECTORALL



# HERE'S PROOF!

PROOF that "SUPER 100" tuner cleaner is BETTER!

Tested by a leading independent laboratory against competitive products!

	SUPER 100	A	B	C
CLEANING	Excellent	Good	Fair	Fair
LUBRICATION	Good	Fair	Fair	Poor
PLASTIC ATTACK	None	None	None	None
FLAMMABILITY	None	None	None	None
CONDUCTIVITY	None	None	Slight	Slight
ANTI-STATIC PROTECTION	Excellent	Fair	Poor	Poor
DRIFT	None	Slight	Yes	Yes



SUPER 100 TUNER CLEANER... for COLOR and Black and White TV tuners  
6 oz. spray can with INJECTORALL steel needle  
CAT. NO. 100-6 net \$1.95

Buy it at your Electronic Parts Dealer.  
For free catalog on the complete line, write to:

**INJECTORALL ELECTRONICS CORP. • Great Neck, N. Y. 11024**

Circle 22 on reader's service card

## Popular Science Top-Rates Scott's Stereo Tuner Kit (THERE'S A SOUND REASON.)



Popular Science magazine's reviewer said, "I rate the LT-112-B as one of the finest FM tuners available — in or out of kit form." All of this fabulous tuner's critical circuitry comes pre-wired, pre-tested, and pre-aligned... and the full-size, full-color instruction manual makes the rest simple. In just eight hours, you'll have it completed. Again, in the reviewer's words: "Stereo performance is superb, and the set's sensitivity will cope with the deepest fringe area reception conditions... drift is non-existent." See your Scott dealer and review the new LT-112B-1 for yourself. Only \$199.95.



©Copyright 1987, H.H. Scott, Inc.

H.H. Scott, Inc., Dept. 570-12, Maynard, Mass. 01754. Export: Scott International, Maynard, Mass. 01754

Circle 100 on reader's service card

### In the Shop . . . With Jack

(continued from page 16)

a working set, read the cathode current and compare its value to what you had with the original drive. This will tell you what's really going on.

### Divide and conquer

In all cases of flyback trouble, you should divide the circuit into two parts: input (or drive) and load (see Fig. 3). The load includes everything fed by the flyback: yoke, damper, HV rectifier (also regulator and focus rectifiers in color sets), and the boost circuits, including the boosted-boost. The drive section includes the horizontal oscillator and driver, afc and all wave-shaping networks in its output.

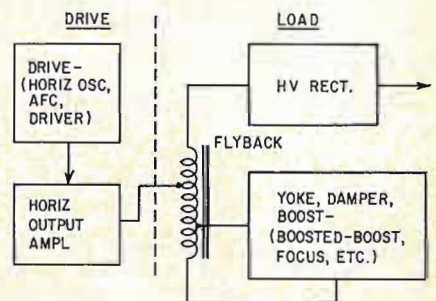

Fig. 3

Load defects are usually pretty easy. They'll affect the output pretty badly—narrow sweep, low HV, etc. If you suspect yoke trouble, substitute the horizontal windings of another yoke, and read the boost voltage. Since the flyback pulse from the yoke is considered as the source of boost, if boost returns to normal, you've confirmed your diagnosis without even seeing a raster!

Input trouble can be harder. A substitute signal can confirm the diagnosis pretty quickly, after a scope check has shown the possibility of trouble—drive signals with excessive flattening of the tops, curvature, too much spiking, and so on; any kind of noticeable deviation from the correct waveform shown on the schematic.

Monitor the cathode current of the output amplifier as a good guide. When you find the real trouble, cathode current will go back down to normal, and the output will come up to normal.

Now, if a sub-signal shows that the set's own oscillator circuit is out of shape somehow, you've got to find out what and why. The cause of this kind of trouble is usually pretty simple (like

(continued on page 26)



# Are you eligible for the Bright Guy Awards?

It's easy to get them—and to get all the business they'll bring you. New customers. More sales. More money.

The Bright Guy Awards is the big program Sylvania's running this year to boost your sales.

Your Sylvania distributor can put your name and address in TV Guide ads in your area. The ads call you "the brightest serviceman in town"—and tell people in your town why they should call you.

You'll get into the Yellow Pages, too, under the heading "TV Service and Repairs."

Once again this year you'll be eligible for over one hundred valuable, interesting



SMB-Bright Guy gifts, just for buying the Sylvania TV replacement parts you normally buy anyway.

And you'll get window displays proclaiming you "the brightest"—the TV serviceman everyone's reading about.

You're eligible for the Bright Guy Awards just by buying Sylvania's famous *color bright 85*<sup>®</sup> picture tube. And our other picture tubes, and our receiving tubes. So see your Sylvania distributor.

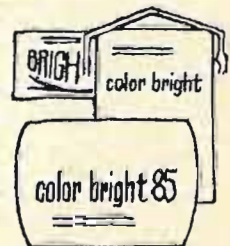

Sylvania Electronic Tube Division, Electronic Components Group, Seneca Falls, New York 13148.

**SYLVANIA**  
A SUBSIDIARY OF  
GENERAL TELEPHONE & ELECTRONICS

Circle 23 on reader's service card

# Winegard put these features in to bring the best color out

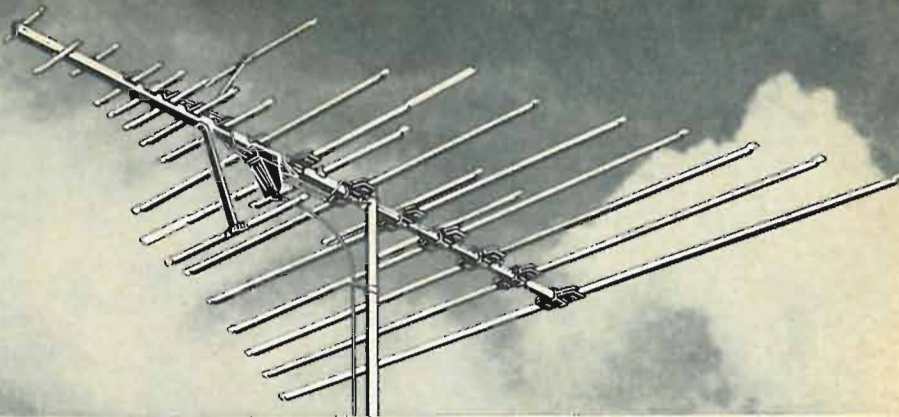

**Downlead and Pre-Amplifier Housing**—permanent housing is built-into the antenna; provides complete weather-proofing for downlead connector cartridge or pre-amp cartridge.

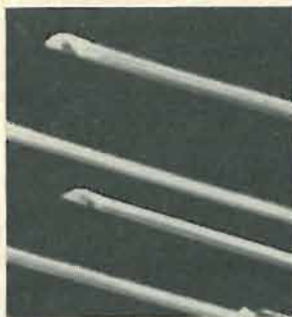

**High Tensile Aluminum Elements; with Gold Anodizing**—aluminum alloy has PSI rating of 38,000 compared to 27,000 PSI for alloys used in other antennas. More than 49% stronger and 29% more resistant to bend and wind distortion. Elements and boom are gold anodized for the only permanent protection against corrosion and fading.



**Solid State Pre-Amplifiers**—incorporate revolutionary new silicon overlay transistors, the best performing and most powerful transistors available for antenna use. Drop into pre-amplifier housing at point of signal interception.



**Ellipsoidal Boom**—the only aluminum shape engineered especially for antenna use; proved far stronger than any other boom design.



**Electro-Lens\* Director System**—patented system absorbs entire signal and focuses it directly onto driven elements for pinpoint directivity.  
\*U. S. Patent No. 2700105  
Canada No. 511984

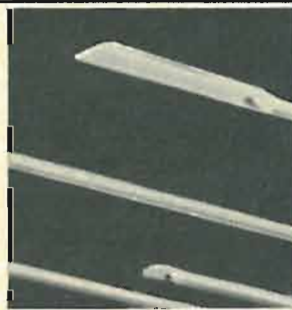

**FM Control Element**—provide exceptionally high gain on FM bands and provide for the attenuation of FM bands in areas where strong FM signals interfere with tv reception.

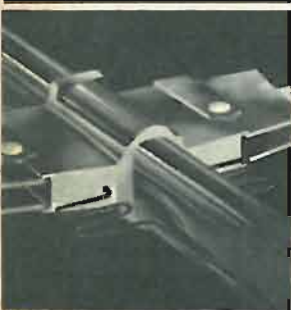

**Impedance Correlators**—patented correlators automatically increase 75 ohm driven elements to 300 ohms to provide 100% signal transfer from antenna to set.



**CS-285 Band Separator** (with printed circuit)—comes at no additional cost with all 82 channel Super Colortrons to separate UHF and VHF signals. Attaches easily to terminals on back of set.



**Vertical Resonant Reflectors**—UHF reflectors achieve highest realizable gain on channels 14 to 83 because of exceptionally large vertical capture area; more UHF gain than any other 82-channel design.

Antenna Model No. _____	Registration Number <b>00000</b>
Installed By _____	Date _____
	
<b>24 Month Antenna Replacement Warranty</b> (2 YEAR)	
See Reverse For Details SAVE FOR YOUR RECORDS	

**2-Year Antenna Replacement Warranty**—the only antenna in the industry that gives your customer a 2-year replacement privilege.

# No wonder so many dealers are selling so many Winegard Super Colortrons so fast.

You're right, that's a lot of features. A lot more than any other antenna ever designed.

But what's really important is what happens when all those features are sandwiched into one super-performing, super-compact antenna.

And just in case you don't know yet, we'll tell you what happens.

First off, you get an antenna so powerful and with such pinpoint directivity (even without solid state pre-amps) that it eliminates ghosts and snow more effectively than anything you've ever seen before.

And when you drop-in an instant-loading pre-amplifier (there are eight to choose from not counting the color spectrum filter) you've got yourself an antenna that does just about anything you want it to do, just about anywhere—

especially when it comes to color tv.

The solid state pre-amplifiers enable you to instantly increase gain on all channels. They let you custom match the Super Colortron to any reception requirement in seconds, using either 75 ohm coax or 300 ohm downlead—and with all connections completely enclosed and protected against the weather.

You can take your choice. There are ultra high gain, low noise 82-channel UHF-VHF-FM pre-amplifiers... VHF-FM pre-amplifiers... UHF pre-amplifiers... and FM pre-amplifiers. And then there's that color spectrum filter. It shuts out electro-magnetic interference... lets only pure TV signals come through for the clearest color pictures ever.

So you see, there's really a lot to talk about when it comes to Super Colortron

antennas, all 14 models—with 7 patents and patents pending.

And that's why we're doing a lot of talking in Life and Newsweek and Sunset. 17 ads, between now and Christmas, telling more than 60,000,000 prospects exactly how remarkable the "transistorized" Super Colortron is.

No wonder so many dealers are selling so many Super Colortrons so fast.

So what are you waiting for?



—biggest, most powerful national advertising campaign in the industry.



**Winegard**  
ANTENNA SYSTEMS

WINEGARD COMPANY

• 3000 KIRKWOOD STREET

• BURLINGTON, IOWA 52601

Circle 24 on reader's service card

©Copyright 1967, Winegard Company, Burlington, Iowa

# Solid State Circuit Boards

Featuring Professional Performance at Low-Budget Prices

Model AA-100  
\$695

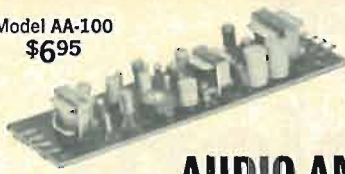

Model AA-300  
\$1495



## AUDIO AMPLIFIERS

Transistorized audio pre-amplifiers and amplifiers capable of delivering 200 MW of audio power, sufficient to drive a small speaker or a number of ear-phones. The AA-100, which includes a mounted volume control, is designed for general purpose audio applications and can also be used to modulate the TR-100 Transmitter (see below). The AA-300, a 200 MW amplifier, has excellent frequency response and low distortion characteristics which make it ideally suited for broadcast, recording, and TV applications. Either amplifier may be powered from a 9 volt source such as a battery or the PS-300 Power Supply. In applications where greater audio power is required, the AA-100 or the AA-300 may be used to drive the Model AA-400 Power Amplifier (see below).

	Model AA-100	Model AA-300
Frequency Response	±3 db, 100 to 12K cps	±1 db, 20 to 20K cps @ 200 MW ±2 db, 20 to 35K cps @ 100 MW
Harmonic Distortion	Less than 3%, 100 to 12K cps	Less than 1%, 20 to 20K cps @ 100 MW Less than 2%, 20 to 20K cps @ 200 MW
Input Impedance	150, 600, and 100K ohms (shielded transformer)	50 to 150 ohms, or 600 ohms, balanced (mu-metal shielded permalloy core transformer) 2K or 100K ohms unbalanced
Gain	70 db	80 db, 50 ohm input, 8 ohm load
Output Impedance	500 ohms and 8 ohms (grain oriented transformer)	200 MW
Circuit	5 transistors, 1 thermistor	7 transistors, 1 thermistor
Power Supply	9 volts DC, 50 MA	9 volts DC, 100 MA
Size	5½" L x 1¾" W x 1" H	8" L x 2¼" W x 1½" H
Weight	3½ ounces	12 ounces

## 1-WATT AUDIO POWER AMPLIFIER



Model AA-400  
\$995

A transistorized audio power amplifier that can be driven to a full 1-watt output by a 1.5 volt signal. When the AA-400 is used with the Round Hill AA-100 or AA-300 Amplifier, a complete high gain, 1-watt audio system is obtained. Power can be furnished by any stable DC source delivering 14 volts at 150 MA, such as the PS-300.

Frequency Response..... ±1 db, 20 to 20K cps @ 1 watt  
Harmonic Distortion..... Less than 1.5%, 20 to 20K cps @ 1 watt  
Input Impedance ..... 500 ohms and 2,000 ohms

Output Impedance ..... 4 to 16 ohms  
Circuit ..... 4 transistors  
Power Supply ..... 14 volts DC, 150 MA  
Size ..... 3½" L x 2" W x 2" H  
Weight ..... 3 ounces

## REGULATED POWER SUPPLY

The PS-300 is a zener-referenced, voltage regulated power supply which delivers a highly stable, extremely low ripple DC output of 9 volts with loads up to 200 MA and an unregulated output of 14 volts DC. The PS-300 is ideally suited for transistor circuit applications requiring a well-filtered regulated DC source, and may be used to furnish power to all Round Hill circuit boards.

Input Voltage ..... 105-120 volts AC, 60 cps, 5 watts  
Regulation ..... Line → load 5 MV  
Ripple ..... Under full load 10 MV, peak-to-peak  
Maximum Load Current ..... 200 MA



Model PS-300  
\$1895

Output Voltage..... 9 volts DC fully regulated;  
14 volts DC unregulated  
Size ..... 4½" L x 2" W x 1½" H  
Weight ..... 23 ounces (with transformer)

## TRANSMITTER

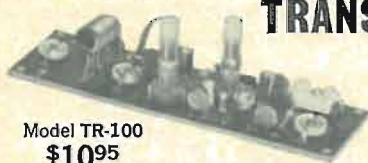

Model TR-100  
\$1095

The TR-100 is a complete crystal controlled Transmitter for the Citizens' Band. It is factory pre-tuned and supplied with a channel 10 crystal. The Transmitter is capable of an RF output in excess of 100 MW and may be modulated with the Round Hill AA-100 Amplifier. Transmitter power supply requirements are 9 volts DC which can be obtained from the PS-300 Power Supply.

Circuit ..... Crystal controlled, 3 transistors  
Frequency Range..... Any CB channel (channel 10 crystal supplied)  
Modulation..... CW or AM with external modulator such as Round Hill AA-100

RF Output ..... 100 MW, 50 ohm load  
Power Supply ..... 9 volts DC, 50 MA  
Size ..... 5½" L x 1¾" W x 2" H  
Weight ..... 3½ ounces  
Additional CB Crystals ..... \$3.00 each

**ROUND HILL ASSOCIATES INC.** A SUBSIDIARY OF MILO ELECTRONICS  
434 Avenue of the Americas, New York, N.Y. 10011

PLEASE SEND ME THE FOLLOWING CIRCUIT BOARDS:

MODEL	QTY.	PRICE ea.	AMOUNT
AA-100 AUDIO AMPLIFIER		\$ 6.95	\$
AA-300 AUDIO AMPLIFIER		\$14.95	\$
AA-400 AUDIO POWER AMPLIFIER		\$ 9.95	\$
PS-300 POWER SUPPLY		\$18.95	\$
TR-100 TRANSMITTER		\$10.95	\$
CB CRYSTAL (channel: )		\$ 3.00	\$
TOTAL:		\$	\$

Send postpaid—enclosed is full payment.  
 Send C.O.D.

NAME \_\_\_\_\_  
ADDRESS \_\_\_\_\_  
CITY \_\_\_\_\_  
STATE \_\_\_\_\_ ZIP \_\_\_\_\_

In the Shop . . . With Jack

(continued from page 22)

all others!); too much leakage in a small capacitor, or a resistor that has drifted off value too far.

A wee bit of leakage in the coupling capacitor from oscillator output to amplifier grid will really shake things up, by upsetting the dc bias level on the grid. (This of course, determines the cutoff point of the amplifier, and the amount of time it is held in conduction, dissipating power.)

Normally, this kind of trouble will not be in the frequency-determining parts of the circuit or in the afc. If it is, you can certainly tell! The most common cause will be a defective "saw-forming network" somewhere between the oscillator and output.

### Red hot mystery

Once in a while you'll find a trouble, the cause of which won't be a short or a leak, but an open input capacitor, as in the B+ boost filter circuit shown in Fig. 4.

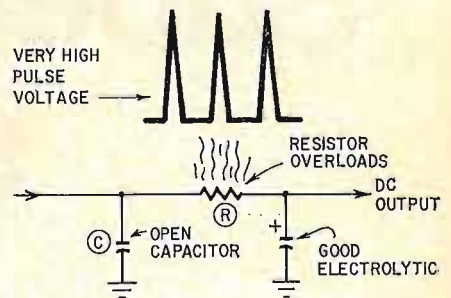

Fig. 4

If the input filter capacitor is open, a greater proportion of the pulses goes through the resistor; some of which are bypassed to ground by the output filter capacitor and some of which get into other circuits to cause other troubles.

Under this circumstance you could wind up with a big mystery . . . the resistor would run red hot even though there is nothing abnormal on the load side to draw an excessive amount of current.

To find these things, use the scope again; it's the only thing that'll let you see what's going on. Look for the presence of high pulse voltages in what should be "pure dc" circuits. Hook the scope to the circuit, and then bridge good capacitors across all suspected ones. When you find the open one, the pulse will just about disappear.

Just remember the old adage: "This thing worked, once, with these part values in it. So, if I can get all the parts back to where they were then, it'll work again!" **R-E**



# Merry Crystals from...



Send for our catalog...  
It will cost you nothing.



**SENTRY MANUFACTURING COMPANY**  
**1634 Linwood Boulevard - Oklahoma City, Oklahoma 73106**

**PHONE: 405-232-1431-TELEX: 071-361-TWX: 910-831-3175**

# 10 Reasons why RCA Home Training is Your best investment for a rewarding career in electronics:

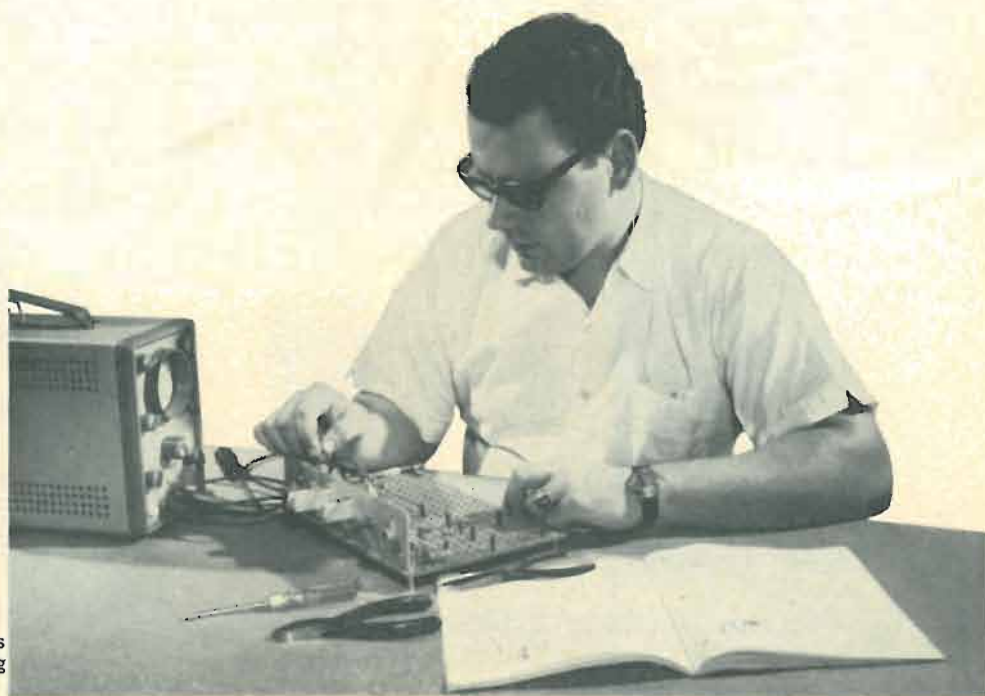

Performing transistor experiments on programmed breadboard — using oscilloscope.

## 1 LEADER IN ELECTRONICS TRAINING

When you think of electronics, you immediately think of RCA... a name that stands for dependability, integrity and pioneering scientific advances. For over a half century, RCA Institutes, Inc., a service of Radio Corporation of America, has been a leader in technical training.

## 2 RCA AUTOTEXT TEACHES ELECTRONICS FASTER, EASIER, ALMOST AUTOMATICALLY

Beginner or refresher, AUTOTEXT, RCA Institutes' own method of programmed Home Training will help you learn electronics more quickly and with less effort, even if you've had trouble with conventional learning methods in the past.

## 3 THOUSANDS OF WELL PAID JOBS ARE NOW OPEN TO MEN SKILLED IN ELECTRONICS

RCA Institutes is doing something positive to help men with an interest in electronics to qualify for rewarding jobs in this fascinating field. Every year, literally thousands of high paying jobs in electronics go unfilled just because not enough men take the opportunity to train themselves for these openings.

## 4 WIDE CHOICE OF CAREER PROGRAMS

Start today on the electronics career of your choice. On the attached card is a list of "Career Programs", each of which starts with the amazing AUTOTEXT method of programmed instruction. Look the list over, pick the one best suited to you and check it off on the card.

## 5 SPECIALIZED ADVANCED TRAINING

For those already working in electronics or with previous training, RCA Institutes offers advanced courses. You can start on a higher level without wasting time on work you already know.

## 6 PERSONAL SUPERVISION THROUGHOUT

All during your program of home study, your training is supervised by RCA Institutes experts who become personally involved in your efforts and help you over any "rough spots" that may develop.

## 7 VARIETY OF KITS YOURS TO KEEP

To give practical application to your studies, a variety of valuable RCA Institutes engineered kits are included in your program. Each kit is complete in itself. You never have to take apart one piece to build another. At no extra cost, they're yours to keep and use on the job.

## 8 FROM RCA INSTITUTES ONLY - TRANSISTORIZED TV KIT, VALUABLE OSCILLOSCOPE

Those enrolled in RCA's television course or program receive complete transistorized TV Kit. All students receive a valuable oscilloscope—both at no extra cost and only from RCA Institutes.

## 9 UNIQUE TUITION PLAN

With RCA Home Training, you progress at the pace that is best for you! You only pay for lessons as you order them. You don't sign a long-term contract. There's no large down-payment to lose if you decide not to continue. You're never badgered for monthly

bills. Even if you decide to interrupt your training at any time, you don't pay a single cent more.

## 10 RCA INSTITUTES GRADUATES GET TOP RECOGNITION

Thousands of graduates of RCA Institutes are now working for leaders in the electronics field; many others have their own profitable businesses. This record is proof of the high quality of RCA Institutes' training.

### CLASSROOM TRAINING ALSO AVAILABLE

If you prefer, you can attend classes at RCA Institutes Resident School, one of the largest of its kind in New York City. Coeducational classroom and laboratory training, day and evening sessions, start four times a year. Simply check "Classroom Training" on the attached card for full information.

### JOB PLACEMENT SERVICE, TOO!

Companies like IBM, Bell Telephone Labs, GE, RCA, Xerox, Honeywell, Grumman, Westinghouse, and major Radio and TV Networks have regularly employed graduates through RCA Institutes' own placement service.

**SEND ATTACHED POSTAGE PAID CARD TODAY! FREE DESCRIPTIVE BOOK YOURS WITHOUT OBLIGATION! NO SALESMAN WILL CALL!**

All RCA Institutes courses and programs are approved for veterans under the New G.I. Bill.

**RCA INSTITUTES, INC.** Dept. RE-D7  
320 West 31st Street  
New York, N.Y. 10001

ACCREDITED MEMBER National Home Study Council



## The Most Trusted Name in Electronics

Construction of Multimeter.

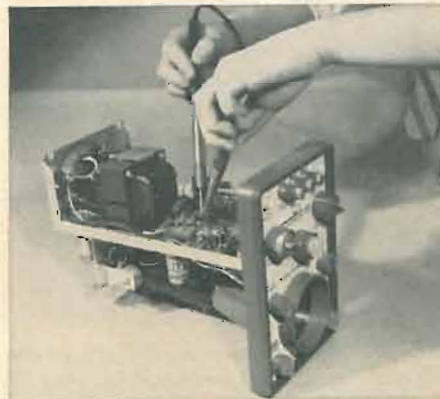

Construction of Oscilloscope.

Temperature experiment with transistors.

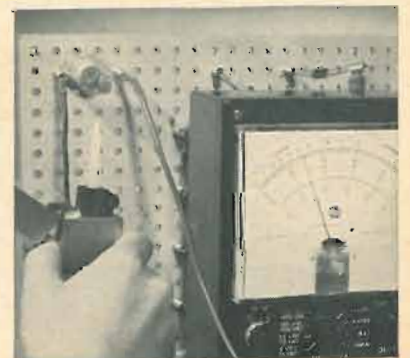

# BUILD A SOLID-STATE TAPE/SLIDE SYNCHRONIZER



**Easy automatic slide changing with commentary from your tape recorder**

By **ROBERT S. HAVENHILL**

SHOWING COLOR SLIDES is a good way to recreate your vacation for friends. By adding commentary on tape, you're relieved of repeating the same thing, and you can't forget what you said last time. But changing slides is still a nuisance.

The synchronizer changes slides for you automatically. All you need is a stereo tape recorder. You put the voice commentary on one track, and a sync signal on the other. When friends drop in, you simply load the projector and the recorder, turn them on, and the show runs automatically. The recorded sync pulses advance slides as your commentary moves ahead. And there are no relays to chatter or stick.

**Theory**

The heart of this synchronizer is a bidirectional thyristor, called a Triac. As you know, a silicon controlled rectifier can conduct only on one-half of an applied ac voltage. Why? Because an SCR is simply a diode with a gate. A Triac consists of essentially *two* diodes in reverse parallel, with a gate. It can conduct on both halves of an ac waveform and can be used as a full-wave control and switch. A Triac can also be gated by ac, which is quite useful.

Figure 1 shows the symbol for a Triac and one method of triggering it. When S1 is closed the gate is connected to anode 2 through current-limiting resistor R2. The Triac then conducts and switches on the ac motor. (Some slide changers are operated by a solenoid, but the principle is the same.)

Figure 2 illustrates a second method of triggering: An ac signal is applied to the gate-anode 1 circuit of the Triac through isolation transformer T1. This second method is used in the tape/slide synchronizer on playback. The recorded sync signal on the tape is fed to the primary of T1. The signal then

triggers the Triac, which conducts and activates the motor (or solenoid) in the projector. The slide advances.

In the record mode, it's necessary to simultaneously trigger the Triac (to advance the slide) and produce an ac signal (to put sync on the tape). The circuit is shown in Fig. 3. Closing S1

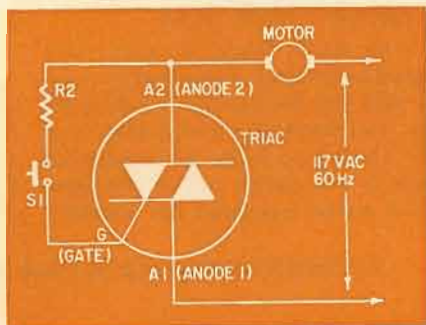

**Fig. 1**—Triac is turned on with voltage between gate and anode 2. It can conduct on both halves of an applied ac voltage.

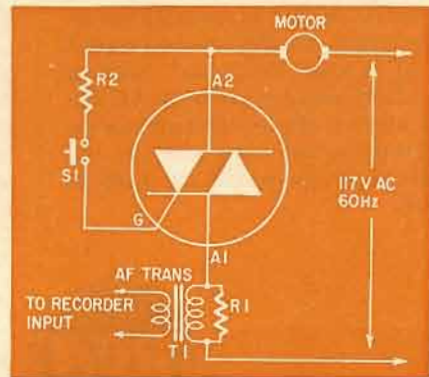

**Fig. 3**—Drop across R1 is sync signal.

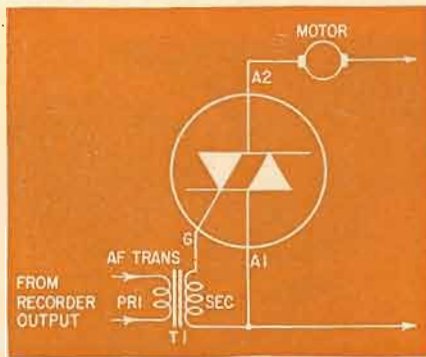

**Fig. 2**—Either ac or dc will trigger the Triac. Signal can also be applied between gate and anode 1 to turn the device on.

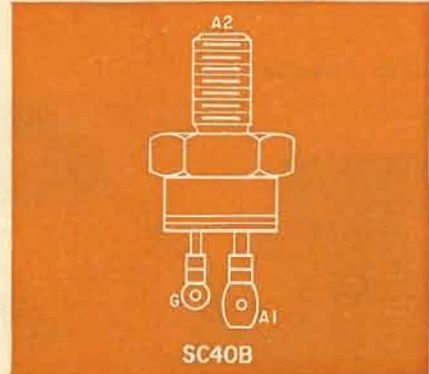

**Fig. 4**—Typical Triac outline, terminal connections, with mounting stud at top.

triggers the Triac and advances the slide. At the same time the 60-Hz ac to the motor passes through R1, causing a 1-volt drop. This 1-volt signal is passed through T1 to the second tape channel, while voice commentary is going on the first channel. Fig. 4 shows outline and terminal connections of the Triac.

### Operation—record

The synchronizer (Fig. 5) is connected to one recording input of the tape recorder through J1, and, to the slide changer through P1. S1 is set to the record function. The tape recorder is then adjusted to record voice from a microphone on the other input channel. The tape is started and when you want to change slides, S2 (or remote switch S3) is pressed. This triggers the Triac into conduction and starts up the slide-changer motor (or solenoid). In a motor-operated changer, when S2 is released the cam switch in the slide changer continues to feed ac to the motor or solenoid until the cycle is complete.

Meanwhile, as S2 is closed, the sync signal is passed through T1, volume control R3 and J1 to the input of the recorder. The level of the sync signal can be set with R3; thus the volume control of the recorder does not need to be changed in going from record to playback.

S3 is an optional remote-control switch. It lets you put sync on tape without having to be near the unit.

### Operation—playback

The cable connecting J1 to the recorder microphone input is now used

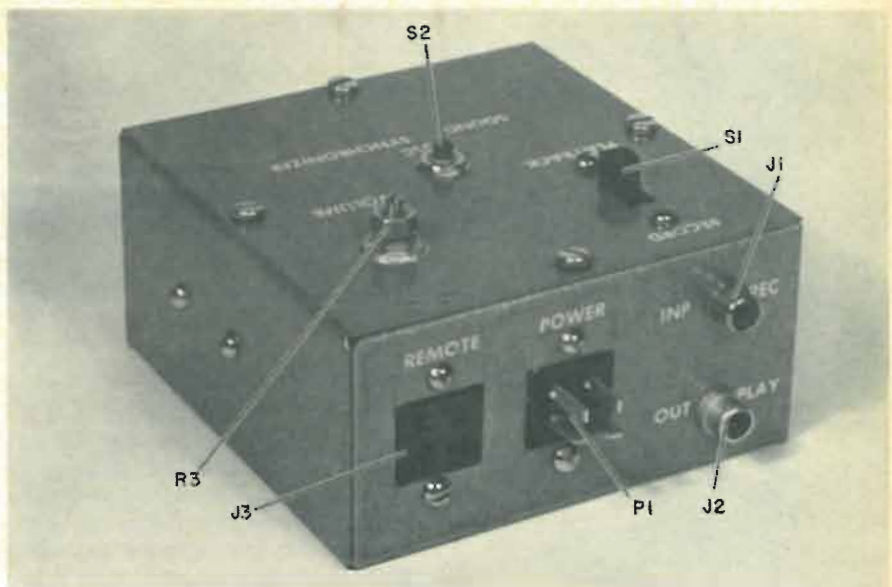

Fig. 6—Remote jack J3 isn't required . . . it is useful for remote operation of S2. Locking control is used for R3 to avoid accidental misadjustment of sync level.

to connect J2 to the external speaker jack of the recorder. (This jack must be on the same channel the sync signals were recorded on.) S1 on the tape/slide synchronizer is set to the playback function, and the recorder controls are set for stereo (or split-channel) playback.

When you play back the tape, you'll hear commentary as usual through the tape speaker. But the sync-channel speaker should be muted, and the sync signal goes into J2 and the primary of T1. The signal is stepped up about 2.5 times by T1 and is then applied to the gate of the thyristor.

Note that closing either S2 or S3 will override all automatic controls and cause a slide change during either

recording or playback.

This synchronizer can be used with nearly any slide changer with remote pushbutton operation, and with any stereo or split-channel tape recorder with power amplifiers. It cannot be used with a tape deck since preamp output isn't high enough to trigger the Triac. The SC40B requires 1.5 to 3 volts and 25 to 100 mA for triggering, and will control up to a 6-amp load at 120 volts.

Transformer T1 isolates the power line from the recorder and gives a fair impedance match between recorder output and the Triac gate. In the record function the impedance match to the recorder input is not good, but

*continued on page 91*

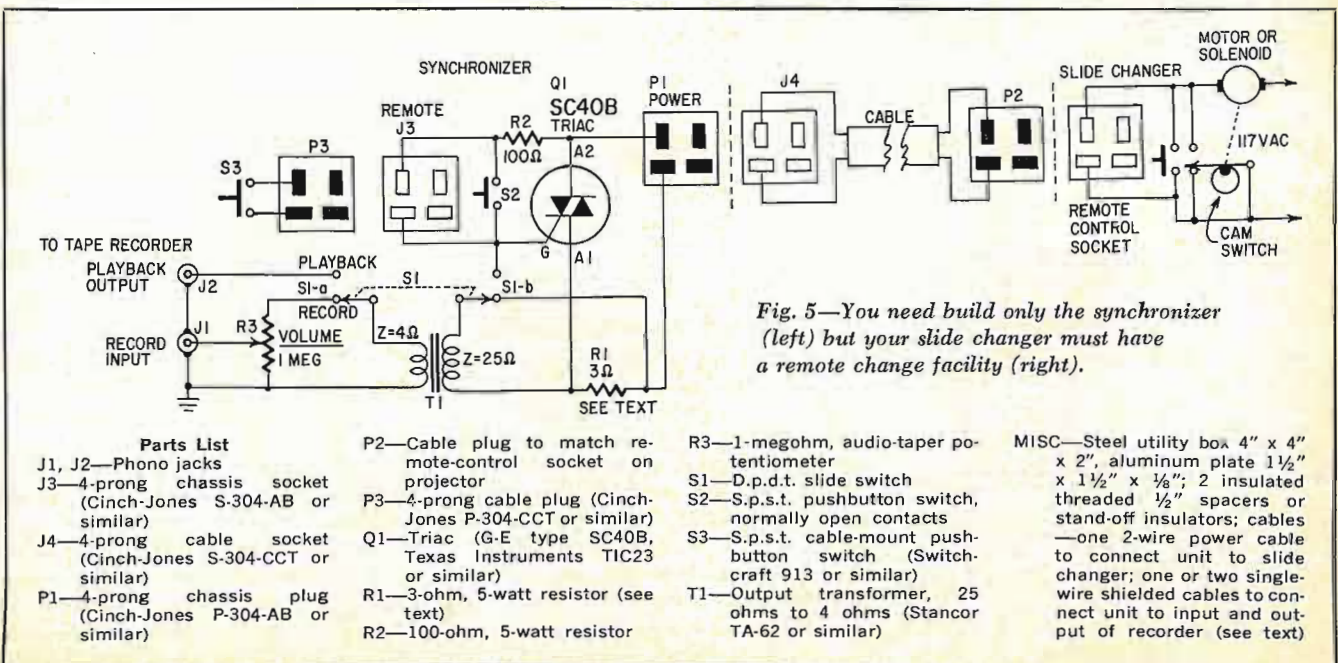

Fig. 5—You need build only the synchronizer (left) but your slide changer must have a remote change facility (right).

# The Solar-Powered

Self-powered amphibious vehicle will get the

By JOHN HOKE

A FULL-SCALE GAMMA GOAT IS A MILITARY vehicle designed to operate effectively on any kind of ground. This solar-powered model doesn't look much like the real thing, but it does have similar rough-terrain capabilities. It manages well on land or water, and solely with light power.

You'll find the goat easy to build. It's assembled almost completely from tailored-to-fit parts that can be obtained easily from local sources (see Fig. 1).

The vehicle frame is made from  $\frac{1}{8}$ " balsa wood, with  $\frac{1}{4}$ " balsa used for the yoke and for local reinforcement of the thinner wood.

To make later finishing much easier, all surfaces of the balsa should be filled before you cut out the parts. Spread shellac or Elmer's glue smoothly over the wood surface. Lightly sand the treated surface (when it's dry) with about a 320-grit paper before cutting. Use a one-sided razor blade or X-Acto knife to cut the wood. Follow the plans shown in Fig. 2.

## Roller construction

Assemble the front roller as shown in Fig. 3. Use acetone or methylene chloride to cement together the lids of two 6-oz Styrofoam cups. Carefully cut a  $\frac{1}{2}$ " hole through the center of both lids. An eyelet "bearing" must be centered in the bottom of each cup, to receive the axle.

Next, make the balsa yoke for the front roller, following the plans shown in Fig. 2. Assemble the yoke and mount the front roller in it (Fig. 4). Install two eyelets "bearings" in the yoke with collars inward. The axle can be a piece of coat-hanger wire.

The drive roller is the only component that must be constructed to fairly exacting tolerances. The arrangement is a fixed-shaft device in which the whole roller and motor revolve around an axle held stationary to the frame of the vehicle. The roller is made of two more Styrofoam cups glued together bottom to bottom as shown in Fig. 5. Be sure to cut well-centered holes large enough to accom-

modate the motor. A sharp razor blade, wet with soapy water, makes cutting the Styrofoam much easier. (Make sure all parts are dry before you cement them.)

Using RTV (room-temperature vulcanizing) rubber, cement the motor mount—a discarded core from a roll of cellophane tape—into place against the bottom of one of the two cups. Center it well so that the motor, when put into the mount, also will be properly centered.

## Making the wheels

The end plates (Fig. 6) seal the drive roller. They also are the wheels on which the model runs on land. Each is made from a balsa disk and a plastic cup cover. The eyelets "bearings" used to support the drive roller in the frame of the vehicle must be carefully centered. Cement a cup lid to each balsa disc so the grooves into which the lip of the cup fits will remain uncovered. Be careful to center the lids well on the balsa discs. Use Silastic for joining these two pieces.

Six paddles are provided for propelling the model in water. Mark paddle locations on the drive roller as follows: Using a compass, draw a circle on paper—make it a bit larger than the drive roller ends. Then make a six-pointed star pattern with the compass. Transfer the points directly to the rim of one cup, marking them with a pen (see Fig. 5).

The paddles should be sanded smooth, and filled with shellac or Elmer's glue. To keep the paddles from trapping air or picking up water when running in water, cut vent holes ( $\frac{1}{32}$ " notches) into the apex of each paddle, as shown in the pattern (Fig. 2).

Next, cement the paddles to the drive roller (Fig. 7).

After the drive-roller end plates and covers have been bonded firmly together, drill out the center holes in which the eyelets will be mounted. Hole size depends upon the size of the eyelets you use. Be sure to strip the eyelets of paint or enamel; they have to carry current from the solar cell to the



Fig. 1—First lay out the materials you will need to build the solar vehicle.

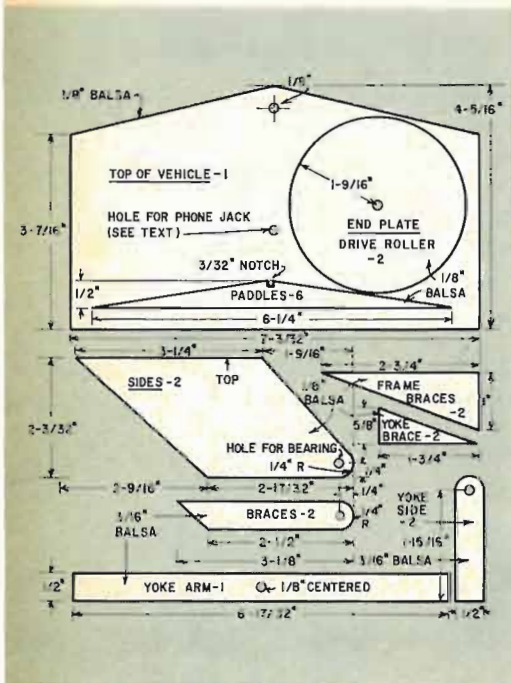

Fig. 2—Unless otherwise marked, sections are cut from two sheets of  $\frac{1}{8}$ " balsa.

# Gamma Goat

kids out in the sun this Christmas

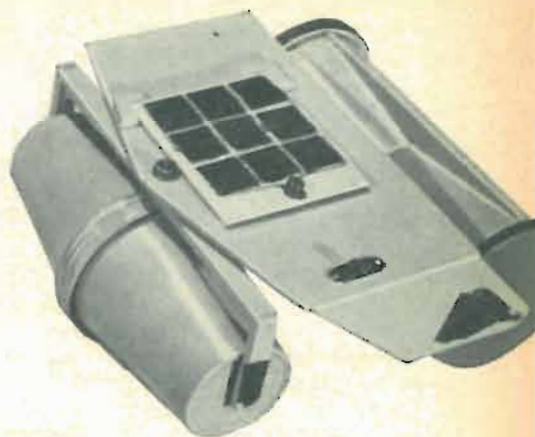

Fig. 3—The front roller assembly: Glue two Styrofoam cup lids together. Then cut  $\frac{1}{2}$ " hole through each lid center for axle. Finally, push cups into lids as shown.

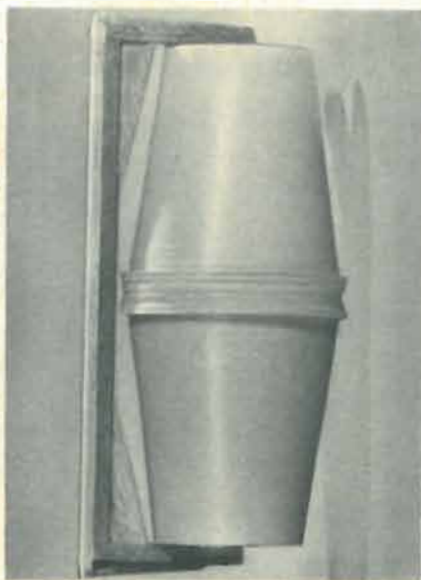

Fig. 4—Front roller is mounted beneath the movable yoke, using two eyelet bearings and a piece of coathanger wire. Unit functions as the steerable roller axle.



Fig. 5—Cement two additional Styrofoam cups together, bottom to bottom, to form the drive (or motor) roller. Then mark ends for locations of six drive paddles.



Fig. 6—Cement a balsa disc (follow the pattern of Fig. 2) to each Styrofoam cup lid. Then slip each "sandwich" on end of a drive-roller cup. Use two cups and lids.



Fig. 7—Use silastic rubber (or bathtub caulk) to cement paddles to the outside of the drive roller. Be careful not to plug or block the vent holes in paddles.

## Materials List

- Balsa wood— $\frac{1}{8}$ " x 8" x 2' (vehicle frame)
- $\frac{1}{4}$ " x  $\frac{3}{8}$ " x  $\frac{1}{2}$ " x 3' (yoke and supports)
- Cups and lids—Styro cups, 6 oz. #67s
- Eyelets—Brass, or painted eyelets
- Model paint—For painting styrene; Spray Pla by Testor's, and AMT lacquer
- Anodized aluminum (or Lucite)—3" x 4" x  $\frac{3}{32}$ "
- Shaft coupler—Motor and drive-shaft coupling; Aristo M233:20, Universal coupling, two required
- Solar cells—Series strings of three cells each; H. & R. No. TM13K490/3; \$2.50 per 3-cell module. Minimum of two modules required. Herback & Rademan, 1204 Arch St., Philadelphia, Pa. 19107
- Phone plug—Subminiature two-conductor (Switchcraft No. 850)
- Phone jack—Subminiature two-conductor (Switchcraft No. TR-2A)
- Gearhead motor—Dc drive motor, Incabloc No. SR601AO, with reducer of 1, 5, 10, 15, or 20 rpm (select one speed) \$8.37 to \$9.42 depending on speed (plus shipping). Portescap U.S., 730 Fifth Avenue, New York, N.Y. 10019
- Switch—D.p.d.t. toggle switch
- Miscellaneous—Dow RTV silicone rubber, bathtub caulk (white-clear), Elmer's glue, spray paints, shellac, epoxy, pins, tape.

motor. As Fig. 8 shows, you'll need four eyelets, each with about 8" of wire attached. Use an enameled wire—No. 26 is a good choice—for this hookup. Make the connection to the outside of the eyelet so the wire won't interfere with the axle. Two eyelets are used in the vehicle frame (Fig. 9) and two more are used in the drive roller (Fig. 10). Wire the drive-roller eyelets to the motor terminals, as shown in Fig. 11.

Instead of eyelet bearings, you can use miniature phone jacks and plugs (transistor radio size) at one end of the drive roller. This is a much easier and more reliable way to apply power to the motor.

Construction of the vehicle frame is straightforward—refer to Figs. 2

and 9. Take care to locate the side panels exactly before you glue them; their leading and trailing edges are not parallel. (Carry the "top" marking onto the pieces, when you cut them.) Use Elmer's glue or a twin-mix epoxy resin for bonding.

### Hole drilling

To make things easier later on, drill out the bearing holes as soon as the side members and their braces have been cemented. Drill all other holes, too, so you won't have to juggle the finished frame while you are trying to drill holes in it.

If you plan to use a "plug-in" solar panel (so you can remove the panel to use it for other purposes) drill

an opening for the phone jack at this time (Fig. 12). If you also wish to use a forward-reverse switch, do necessary drilling and cutting at this time. In all such drilling operations, use pieces of backup wood so the holes will be neat. Add epoxy cement to the wood around the phone jack hole, for strength.

Before spray-painting the frame, sand it lightly with a fine emery paper. When spraying the model, take care not to get any paint on the unfinished roller assemblies; most spray paints will dissolve Styrofoam. A special paint (see Parts List) must be used to finish the rollers.

Assembly of the drive roller comes next. Use a round pin file or a tube of emery paper to clean out the eyelet bearings thoroughly so they will offer

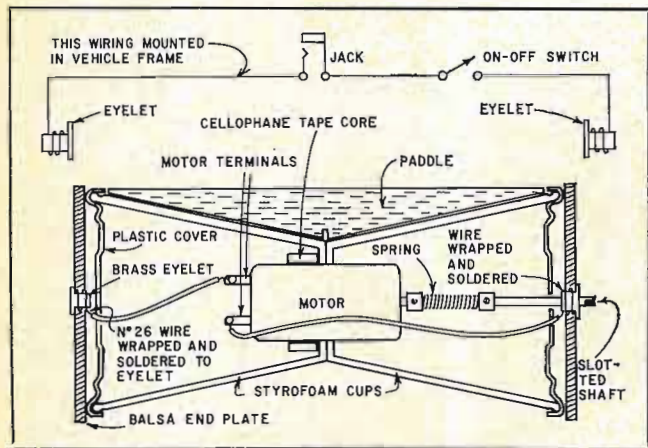

Fig. 8—Cement the motor inside the drive roller with some RTV rubber. Cellophane tape core holds motor securely in place.

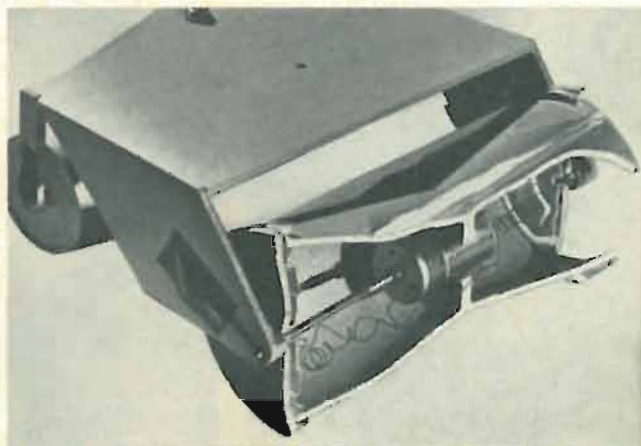

Fig. 9—Motor and drive roller turn when power is applied. Drive shaft is held fixed by coter pin tied to vehicle frame.

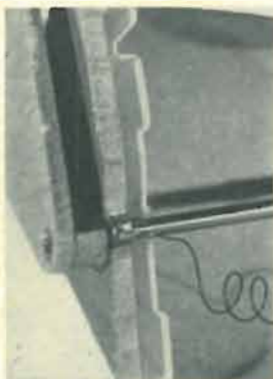

Fig. 10—Solder motor wire to eyelet; mount eyelet in end of drive roller with collar out.

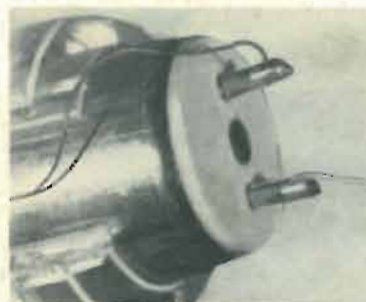
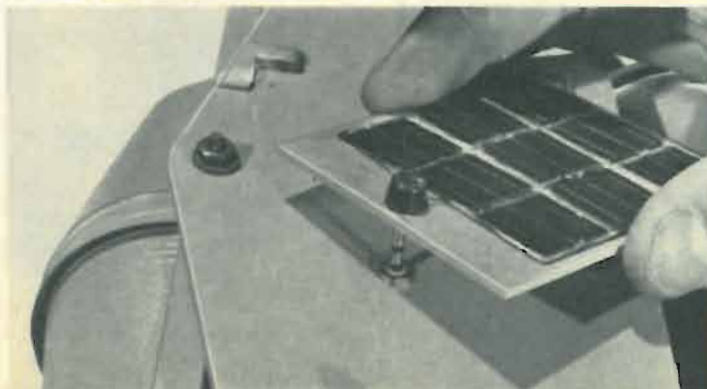

Fig. 11—Solder wires from the drive-roller eyelets to the two motor terminals. Don't overheat.

Fig. 12—Cement the solar cells to piece of Lucite or aluminum with a phone plug at one end. Wire cells, plug in series.





good electrical contact. Carefully study Fig. 8 and you will note that one axle is friction-fitted to the motor shaft with a piece of snug-fitting spring. If the vehicle is to be run in only one direction—that in which the spring will “grab” the shafts—this simple hookup is all that will be needed. If, however, you plan to provide a forward/reverse switch, you will need to use a nonslip coupling, such as one with set screws at both ends.

### Motor coupling

The drive shaft can be a piece of coat-hanger wire, but a length of  $\frac{1}{8}$ " drill rod is better. Cut the axle long enough to let it extend through both the bearing in the drive-roller end

plate and the bearing in the vehicle frame (see Fig. 10). About  $\frac{1}{8}$ " to  $\frac{1}{4}$ " of the shaft should extend beyond the frame bearing. As the shaft must be held stationary at this point, it should be slotted with a file. A  $\frac{1}{16}$ " hole drilled through the tip also will provide a means to anchor the shaft.

When the motor and shaft are in place, the two end plates can be put in place, the cup lips tucking into the grooves of the lids.

The drive-roller assembly will need an axle for use in the opposite end of the assembly when it is placed in the frame. A piece of bare coat-hanger will work, but a piece of heavy copper wire is better, since this axle also must conduct electrical current.

This axle is slipped into place

through both frame and drive-roller bearings, when the drive roller has been positioned in place. You can bolt the axle in place if you wish, but a simple right-angle key-headed member is all that is needed. Use a piece of Mylar tape, placed over the keyed portion, to hold it in place.

When the drive axle is in place, it must be pinned so that it cannot turn. Use a partially straightened-out paper clip, leaving a “key head” on it over which Mylar tape can be put to hold it to the frame. The end slips through the axle slot to keep it from turning.

Before mounting the drive-roller assembly, spray it with a paint that will not dissolve or damage the Styrofoam cups (see Parts List.) Do *not* use heat to hasten drying; it will permanently damage the Styrofoam.

The yoke of the steering roller is secured to the frame with a small nut and bolt. An eyelet can be potted into the frame to serve as a mount if you wish. Washers should be used to distribute the loading this junction must endure. A flat rubber faucet washer should be sandwiched between the yoke and frame both to separate them and to provide enough friction to hold the yoke in any position.

### Final assembly

After the yoke is mounted, the roller assembly that fits into the yoke is secured in the yoke bearings. A single, straightened-out piece of coathanger rod extending through all bearings does the job nicely. An L-bend in one end of the wire provides a lever across which to tape the rod in place to one leg of the yoke.

A word about choice of motors: The gear reduction you select from those listed depends on how you plan to use the vehicle. If you use three strings of solar cells, the goat will go over pretty rough ground with a 10 to 15 rpm motor—in sunlight. Even with a 20-rpm motor, it will manage well on dirt or grass.

If you want it to perform well on water, the higher the rpm the better! (Even a 40-rpm unit will run it on water.) The prototype model was made with a 15-rpm motor, which moves over fairly rough ground; it also runs at a reasonable rate on water.

Under a full sun, it is exciting to watch such a device operate, knowing that the energy source is free! But take care: If you tire of watching the goat—or if the sun goes behind a cloud—don't just go away and leave the Gamma Goat untended. You might forget it. Then, when the sun returns, it will wander off! It's a toy and it's in time for Christmas, so have a Merry Christmas.

R-E



Fig. 13—A 150-watt flood lamp at 4 feet will run the goat on smooth floor indoors.



Fig. 14—In water, the goat sinks in a bit due to motor weight. But it floats!

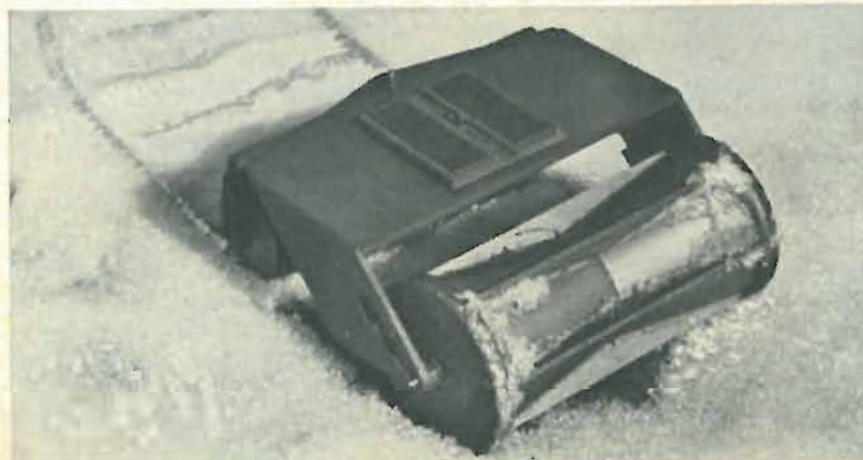
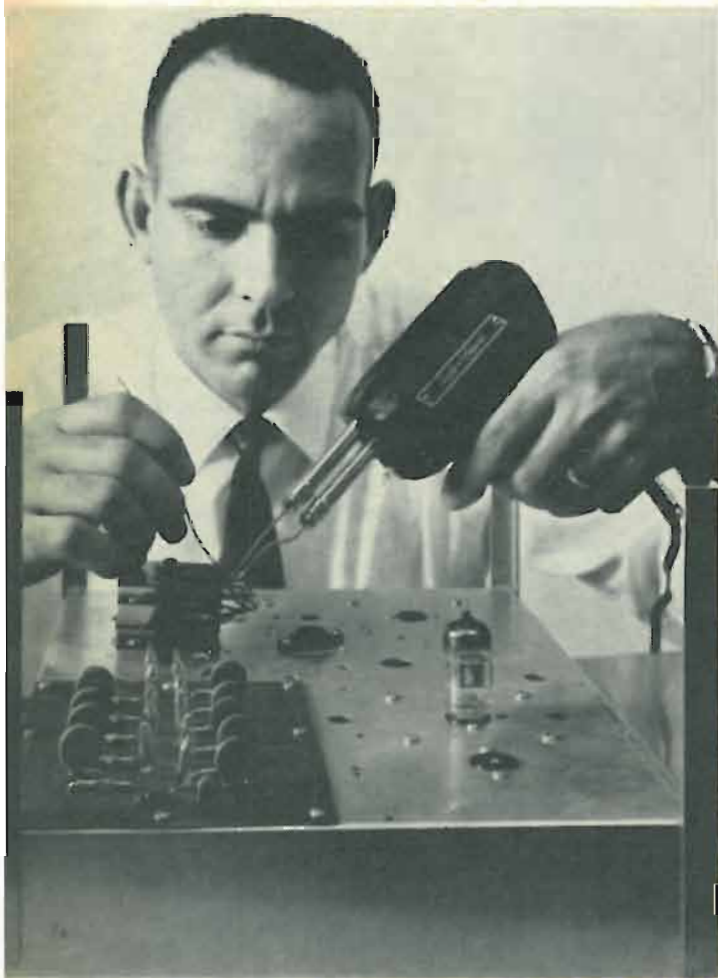

Fig. 15—Drive-roller paddles permit the goat to chop its way through deep snow.

# YOUR FUTURE IN ELECTRONICS



**Exciting, challenging opportunities await  
you in this fast-growing field**

**By RAY CLIFTON**

Photos courtesy of DeVry Institute of Technology, Grantham School of Electronics, National Radio Institute and RCA Institutes, Inc.

**Item:** Today at least 50,000 trained electronics technicians are urgently needed to fill well-paying jobs in the U.S.

**Item:** Additional jobs are being created each year for electronics technicians. The field is expanding rapidly.

**Question:** Are you an electronics technician?

**Question:** Would you like to become one—or become a better one?

**Statement:** Whether you become a (better) technician or not is up to you. Here's how you can.

## **Job Opportunities**

**Consumer electronics:** Installing and servicing home radio and television receivers, hi-fi and stereo equipment, public-address systems, burglar and fire alarms, and other electronic devices are included in this segment of the industry. Some technicians are self-employed, and some work for others.

With widespread public acceptance of entertainment and other electronic equipment for the home, this field is wide open for skilled technicians.

**Industrial electronics:** Installation and service of in-plant gear, including computers, servo systems, microwave equipment, burglar and fire alarms, closed-circuit television equipment, intercoms, electronic machine controls, etc. Most technicians work in a plant; some are field-service representatives traveling around the country with expenses paid, and some are self-employed.

These days the wheels of industry are turned electronically, and technicians are in high demand. Wages are good, with periodic raises and promotions, paid vacations and health benefits.

**Electronics manufacturing:** Quality control, assembly-line inspection and testing, installation and maintenance of in-plant electronic equipment, building prototypes, instrument calibration, etc.

Many technicians in this field are promoted to engineering assistants or associate engineers. They have prestige and a solid future. Salaries are good and employment is steady.

**Broadcasting and communications:** Includes operation, installation and maintenance of transmitters, studio and associated equipment at AM, FM, TV and shortwave broadcast stations. Installing and servicing commercial two-way mobile radio and fixed stations, and telephone equipment. Operation, installation, maintenance of tape, disc and film equipment for motion-picture and recording studios.

More people use radio communications today than ever before. The number of transmitters in use grows each year. All need qualified technicians to service them.

**Hobby electronics:** Some persons like electronics for its own sake. They are hi-fi/stereo addicts, ham radio operators, construction builders or CB enthusiasts. They often study electronics because it makes their hobby more fun. A hobby isn't a job, but playing around with a hi-fi amplifier or a ham rig is an easy way to gain valuable practical experience. An electronics hobby can even help you get a better job.

## **Skills Needed**

Regardless of the type of electronics work you would like to do, you must know a certain amount of theory and have some practical experience. The more you know about any equipment, the better and faster you can get it to work; that means money and personal satisfaction.

**Consumer electronics:** You must know how to use basic test equipment such as a voltmeter, oscilloscope, signal generator, etc. You must be familiar with AM, FM and TV receivers, as well as their antennas, and audio amplifiers and

power supplies. You should understand how transistors, vacuum tubes and semiconductor diodes work, as well as how to handle them.

**Industrial electronics:** You should be as qualified as the man in the consumer electronics field. In addition you must be familiar with the specialized equipment or systems used in your chosen industrial electronics field. Such things as tachometers, Q-meters, dc choppers, magnetic control amplifiers, polyphase rectifier circuits, telemetering equipment, medical equipment, closed-circuit TV systems, TV cameras, etc., are all part of this exciting industry.

**Electronics manufacturing:** You need most of the preceding skills, and more. Since your work can be that of an engineering assistant, you must be able to construct equipment from notes, schematics and other plans. You should know how to use laboratory-type test equipment. You may be given an opportunity to supervise and instruct others.

**Broadcast and communications:** A technician in this field must first have an FCC Commercial Radio Operator license, so he may legally operate, service and maintain radio and TV transmitters. He needs a working knowledge of electronic test instruments and of transmitters. Test equipment includes rf bridges, field-intensity meters, sound-level meters, etc. Other equipment includes TV sync generators and cameras, subcarrier generators and single-sideband equipment.

### Acquisition of Skills

There are several ways to become technically qualified for a rewarding career in electronics.

**Self-study:** You buy a book, read it, work some problems and examples, perhaps build some electronic devices to get to know circuit operation and hardware. This method requires much self-discipline. You have no teacher to guide you or explain things not covered in the book. Many technicians have started this way, but as their thirst for knowledge grew with their experience, many of them found it to their advantage to pursue a more formalized program.

**On-the-job training:** Quite a few technicians got their start helping out around a radio or TV shop after school. They learned the tools of the trade, the hardware and much of the jargon. However, on-the-job training is only as good as the quality of supervision and programming of activities. Just taking any job in any radio and TV store or factory is not the answer.

But on-the-job training, while it puts you in electronics right away and brings in income, can be a dead end unless you also study theory. Many persons use the self-study method along with work. Some attend manufacturer's seminars and technician association training meetings. Most technicians at one time or another have beefed up their training with a correspondence course.

**Home study (Correspondence course):** You follow formal lesson plans designed by experts to include all needed information. After studying a lesson, you answer questions on the subject; your answers are read and graded by instructors. They will answer any questions you have and give you extra help when necessary. Kits are often used. You begin your program with a course in basic electronics, then pick a more specialized area to work in, such as industrial electronics or consumer electronic servicing.

You can study at home while you are employed full-time. You set your own speed, and you study at your convenience. Costs and time are determined by the complexity and completeness of a course.

**Classroom study:** For many persons, this is the best way to learn electronics in the shortest time. You attend regular classes, meet your instructor face-to-face at each session,

and follow a planned course. You learn not only "book theory" but perform bench experiments and get the feel of the hardware.

### Supplementary Reading

You will find many fine electronics books and magazines in your local electronics distributors, bookstores, and newsstands. Some books are short and deal with a specific subject such as how transistors work using a vom, etc. Oth-



*Home-study courses often include useful electronic projects.*



*With training, you can be a part of the big TV network shows as a video control technician.*

ers are complete texts, and still others are comprehensive reference books. Practically all electronics technicians read such books and magazines from time to time to keep up with the field.

### Guidance

Many companies will advise you how to go about qualifying for employment with them. Some have complete on-the-job training programs for new employees, and will start you as an apprentice with little or no electronics knowledge at first.

You can also seek guidance from the last school you attended, or from the school you would like to attend. You can write any school and ask them for their catalog and other descriptive material about the courses they offer. The National Council of Technical Schools and the National Home Study Council (see the partial listing of electronic schools for address and more photos on page 40) will also provide you with helpful information.

**R-E**

# Q. and A. On an Electronics Career

**Q:** Can a woman study electronics and work in the field?  
**A:** Yes. Sex is no barrier to training or employment. Knowledge, ability and experience are what count.

**Q:** Is there any age limit for new students?  
**A:** Generally no, but educational prerequisites make it difficult for young children to qualify. Teenagers and persons in their 60's have benefited from electronics training.

**Q:** What educational requirements are there?  
**A:** For vocational training (such as radio-TV servicing or industrial electronics) at least an 8th-grade education is necessary. For engineering technology (assistant to engineer in manufacturing) a student must often be a high-school graduate. These are general rules; each school has its own requirements.

**Q:** Does a student *have* to take a basic electronics course first?  
**A:** Not always. If you're already working in electronics and have basic knowledge, you may qualify for an intermediate or advanced course. Most schools have guidance counselors to help you choose the right course for you.

**Q:** Does an electronics school have contact with major electronics employers to assist graduates to obtain jobs?  
**A:** Yes—most schools maintain placement services for such purposes.

**Q:** Will a school guarantee a graduate a job?  
**A:** An ethical school won't make such a promise. The final decision on employment is a personal one between graduate and employer.

**Q:** Do employers recognize diplomas?  
**A:** Yes. Accredited schools must meet standards which require that only students who have made passing grades obtain diplomas. Thus the certificate means you have satisfactorily completed a course or program.

**Q:** Does a student have to choose his entire program at once?  
**A:** No—you can take each course as you want it. (However, you must take certain subjects before advanced ones.)

**Q:** Can a student take a home-study course, then transfer to resident school and receive credit?  
**A:** Generally yes, depending on the school(s) involved. It is usually easier to do this at the same school.

**Q:** Can members of the armed forces on active duty enroll in correspondence courses?  
**A:** Yes. Since lessons are handled by mail, it makes no difference where the student is.

**Q:** Can veterans attend electronics schools under the GI Bill?  
**A:** Yes. Most schools are approved for veteran training.

**Q:** Don't training courses become obsolete, with such new devices as FET's and IC's appearing in electronics?  
**A:** Yes—advances in electronics make lessons out-of-date from time to time. Because of this, schools constantly revise and update their courses to include the latest technical material. Some schools even issue regular bulletins to students and graduates, with details of new devices and techniques.



*All schools today use training aids and test equipment. You learn the functions, the symbols, and how the circuits work.*



*Part of your training should be working in the laboratory to develop the feel of tools, test equipment and troubleshooting.*

## Electronics Schools Directory

- |   |   |
|---|---|
| Academy Avionics<br>Reno-Stead Airport<br>Reno, Nev.  | Indiana Home Study Institute<br>P.O. Box 1189<br>Panama City, Fla. 32401                |
| American Institute of<br>Engineering and Technology<br>1139 W. Fullerton Pkwy.<br>Chicago, Ill. 60614 | International Correspondence<br>Schools<br>Scranton, Pa. 18515                          |
| American School<br>Drexel Ave. at 58 St.<br>Chicago, Ill. 60637                                       | National Radio Institute<br>3839 Wisconsin Ave., N.W.<br>Washington, D.C. 20016         |
| Canadian Institute of<br>Science & Technology<br>263 Adelaide St., W.<br>Toronto, Ont., Canada        | National Technical Schools<br>4000 So. Figueroa St.<br>Los Angeles, Calif. 90037        |
| Capitol Radio Engineering Institute<br>3224 16 St., N.W.<br>Washington, D.C. 20010                    | Niles Bryant School<br>3631 Stockton Blvd.<br>Sacramento, Calif.                        |
| Central Technical Institute<br>1644 Wyandotte St.<br>Kansas City, Mo. 64108                           | Northrop Institute of Technology<br>1199 W. Arbor Vitae<br>Inglewood, Calif.            |
| Cleveland Institute of Electronics<br>1776 E. 17 St.<br>Cleveland, Ohio 44114                         | Philco Technical Institute<br>219 No. Broad St.<br>Philadelphia, Pa. 19107              |
| Commercial Trades Institute<br>1400 W. Greenleaf Ave.<br>Chicago, Ill. 60626                          | RCA Institutes, Inc.<br>320 W. 31 St.<br>New York, N.Y. 10001                           |
| Cook's Institute of Electronics<br>Engineering<br>P.O. Box 10634<br>Jackson, Miss. 39209              | Sams Technical Institute, Inc.<br>1720 E. 38 St.<br>Indianapolis, Ind. 46218            |
| Coyne Electronics Institute<br>1501 W. Congress Pkwy.<br>Chicago, Ill. 60607                          | Technical Training International Inc.<br>10447 So. Torrence Ave.<br>Chicago, Ill. 60617 |
| DeVry Institute of Technology<br>4141 Belmont Ave.<br>Chicago, Ill. 60641                             | Tri-State College<br>2487 College Ave.<br>Angola, Ind. 46703                            |
| Elkins Institute<br>2603 Inwood Rd.<br>Dallas, Tex. 75235   | Valparaiso Technical Institute<br>Valparaiso, Ind. 46383                                |
| Grantham School of Electronics<br>1505 N. Western Ave.<br>Hollywood, Calif. 90027                     |   |
| Heald College<br>1215 Van Ness Ave.<br>San Francisco, Calif. 94109                                    |   |
| Hemphill Schools<br>1584 W. Washington Blvd.<br>Los Angeles, Calif. 90007                             |   |

Some schools offer correspondence courses, some residence training, some both. This is only a partial listing. For more information about other schools, write:

- National Council of  
Technical Schools  
1507 M St., N.W.  
Washington, D.C. 20005  
National Home Study Council  
1601 18 St., N.W.  
Washington, D.C. 20009



# The FCC License ...and how to get it

Your admission ticket to a career.

By **THOMAS R. HASKETT**

ONE OF THE MOST COMMON "DIPLOMAS" FOUND IN ELECTRONICS is the Commercial Radio Operator license issued by the Federal Communications Commission. By act of Congress, most of the nearly 2 million radio and television transmitters used in the US today must be operated—and all must be serviced and maintained—only by persons holding one of the various classes of FCC operator license.

To obtain a "ticket," you must pass a written examination covering, among other things, electronics and radio theory and practice. Thus, possession of an FCC license is generally considered proof of electronics knowledge. Such proof can help you obtain a technical job, even though the position may not legally require a license.

To work as a technician servicing transmitting equipment you must have a ticket, of course. But even if you don't intend to troubleshoot transmitters, a license can be helpful. At nearly half of the 7000 US broadcast stations, for instance, you'll be a more valuable employee if you have a Radiotelephone Third-Class license with a broadcast endorsement. Whether you're an announcer, a typist or a janitor, you can then legally perform routine transmitter operation.

## License requirements

To be eligible, you must be a US citizen and capable of transmitting and receiving spoken messages in English. Further requirements depend on the class of license you want. Table I lists the elements of the examination you must pass for each license. Here's what the exam covers:

**Element 1—Basic Law:** Radio laws, treaties and regulations which every operator must know.

**Element 2—Basic Operating Practice:** Procedures used when communicating by means of radiotelephone stations.

**Element 3—Basic Radiotelephone:** Technical, legal and other matters which apply to radiotelephone stations (other than broadcast). Covers general electronics theory.

**Element 4—Advanced Radiotelephone:** Advanced technical, legal and other matters which apply particularly to AM, FM and TV broadcast stations. Covers advanced electronics theory.

**Element 5—Radiotelegraph Operating Practice:** Procedures used when communicating by means of radiotelegraph stations.

**Element 6—Advanced Radiotelegraph:** Technical, legal and other matters which apply to all classes of radiotelegraph stations, and associated matters such as radio navigational aids and message traffic routine. Covers advanced electronics theory.

**Element 7—Aircraft Radiotelegraph:** Basic theory and practice in the operation of radio communication and navigational systems used on aircraft.

**Element 8—Ship Radar Techniques:** Specialized theory and practice which applies to installation, servicing and maintenance of ship radar equipment used for marine navigation.

**Element 9—Basic Broadcast:** Basic regulatory matters which apply to the operation of AM and FM broadcast stations.

Table I—Requirements for FCC Operator Licenses

	Element 1 Basic Law	Element 2 Basic Operating Practice	Element 3 Basic Telephone	Element 4 Advanced Telephone	Element 5 Telegraph Operating Practice	Element 6 Advanced Telegraph	Element 7 Aircraft Telegraph	Element 8 Ship Radar	Element 9 Basic Broadcast	Code Speed	Special Require- ments
<b>RADIOTELEPHONE</b>											
First-Class License	X	X	X	X				(3)			
Second-Class License	X	X	X					(3)			
Third-Class Permit	X	X							(4)		
Restricted Permit											At least 14 yrs old; declaration only req'd.
<b>RADIOTELEGRAPH</b>											
First-Class License	X	X			X	X	(1)	(3)		25/20	At least 21 yrs old; 1 year service
Second-Class License	X	X			X	X	(2)	(3)		20/16	
Third-Class Permit	X	X			X					20/16	

1 Aircraft telegraph endorsement required on this license to operate radiotelegraph station on aircraft. (Exception: If license holder has been chief or sole operator in such capacity prior to 2-15-50.)  
2 Aircraft telegraph endorsement, 25-wpm code speed, and at least 18 years of age required on this license to operate radiotelegraph station on aircraft.

3 Ship radar endorsement required on these licenses to service and maintain ship radar equipment.

4 Basic broadcast endorsement required on this license to operate certain classes of broadcast transmitters.

5 First figure indicates plain-language words; second figure indicates 5-character code groups; both per minute.

## Preparing for the exam

There are two general ways to study: One is to buy (or borrow) a handbook. Several are listed in Table II.

These books contain sample questions similar to those contained in the FCC exam. Each question is followed by the correct answer and the theory behind it. The best way to study is to cover the answer with a piece of paper while you read the question. Then write your answer. If you are correct, check that question off and go on to the next. When you miss a question, study the background material and work a few problems based on the subject. Refer to other books if you like; the object is to become familiar with the theory and practice, not just the answer.

The second way to study for the FCC exam is to enroll in a correspondence or residence school and take a course designed to prepare you on this subject.

To pass the examination for any class of radiotelegraph license, you must be able to transmit and receive International Morse code at the rate specified in Table I.

Code instruction is seldom available at the schools

### Table II—License Study Manuals

Commercial Radio Operator's Question & Answer Guide, by Martin Schwartz. No. 8-01 (Elements 1, 2 and 9) 1964, \$0.75; No. 9-01 (Element 3) 1967, \$1.95; No. 10-01 (Element 4) 1958, \$1.25. Ameco Publishing Corp., Williston Park, N.Y.

First-Class Radiotelephone License Handbook, BON-2, by E. M. Noll. Howard W. Sams & Co., Inc., Indianapolis, Ind., 1966, \$5.25.

Radar License Endorsement Handbook, RLH-1, by E. M. Noll. Howard W. Sams & Co., Inc., Indianapolis, Ind., 1964, \$2.95.

Radio Operating Questions and Answers, 13th Edition (text), by J. Hornung and A. McKenzie. McGraw-Hill Book Co., Inc., New York, N.Y., 1964, \$6.00.

Radio Operator's License Handbook, RON-1, by E. M. Noll. Howard W. Sams & Co., Inc., Indianapolis, Ind., 1965, \$3.25. (Covers Third-Class Radiotelephone license with broadcast endorsement.)

Radio Operator's License Q & A Manual, 7th Edition, by Milton Kaufman. Hayden Book Co., Inc., New York, N.Y., 1966, \$7.95.

Radiotelephone License Manual, 3rd Edition, by Woodrow Smith. Editors & Engineers, Ltd., New Augusta, Ind., 1962, \$5.75.

Second-Class Radiotelephone License Handbook, 3rd Edition, QAN-2, by E. M. Noll. Howard W. Sams & Co., Inc., Indianapolis, Ind., 1966, \$4.95.

Successful Preparation for FCC Radio Operator License Examinations, by O. L. Geiger. Prentice-Hall, Inc., Englewood Cliffs, N.J., 1960, \$9.95.

mentioned; they usually prepare you only for radiotelephone exams. Code-practice tapes, records and books are available through electronics distributors.

## Taking the exam

If you live in or near any of the cities listed in Table III, look up the FCC field-office phone number and call them for information. Exams are usually given each week at these offices.†

If you live away from the cities in Table III, your best bet is to write to the nearest listed office. Ask them where your nearest examining point is, and when the next exam will be given. Ask them also to send you one each of FCC Forms 756 and 756-B (the official applications for license). When you plan to take an exam anywhere but an FCC district office (those shown in Table III) you must fill out and mail in the application in advance.

You must pay a fee with your application for a license.

†One useful book is *Learning the Radiotelegraph Code*, American Radio Relay League, Newington, Conn., \$0.50.

†Don't apply to a field office for a Restricted Radiotelephone Permit. While there are some exceptions, you should usually write to FCC, Gettysburg, Pa. 17325. Ask for FCC Form 753, which is the application for this class of permit.

### Table III—FCC Field Offices

P.O. Box 644	Boston, Mass. 02109
Anchorage, Alaska 99501	Detroit, Mich. 48226
Los Angeles, Calif. 90014	St. Paul, Minn. 55102
San Francisco, Calif. 94126	Kansas City, Mo. 64106
San Pedro, Calif. 90731	Buffalo, N. Y. 14203
Denver, Colo. 80202	New York, N. Y. 10014
Washington, D.C. 20555	Portland, Ore. 97205
P.O. Box 150	Philadelphia, Pa. 19106
Miami, Fla. 33101	P.O. Box 2987
Atlanta, Ga. 30303	San Juan, P. R. 00903
Honolulu, Hawaii 96808	Dallas, Tex. 75202
Chicago, Ill. 60604	Houston, Tex. 77002
New Orleans, La. 70130	Norfolk, Va. 23510
Baltimore, Md. 21202	Seattle, Wash. 98104
Address all communications to "Engineer in Charge, Federal Communications Commission."	

If you appear at an FCC district office in person, you may pay cash; otherwise send only check or money order by mail. Cost depends on the class of license or permit: First-Class, \$5; Second-Class, \$4; Third-Class, \$3; Restricted Radiotelephone permit, or renewal of any license, or endorsement of license, or duplicate license, \$2.

When you take the exam, you'll be given the code test first if you apply for any class of Radiotelegraph license. You must receive and transcribe consecutive words or code groups for a period of one minute without error at the specified rate of speed. If you fail the code test, you won't be given the written exam.

You will be given a series of printed questions to answer in writing, and (for some elements) you'll be required to draw (or correct) a few schematic diagrams. The minimum passing grade for each element is 75%.

If you fail any element, you are not allowed to go any further in the exam. You will be issued, however, whatever license you have qualified for. For example, suppose you applied for a Radiotelephone First-Class license, passed Elements 1 and 2, but failed Element 3. You would then be issued a Radiotelephone Third-Class permit.

Once you have failed an element, you normally cannot take another commercial exam for two months. (If you have urgent need for the license and are willing to do further study at once, however, you can apply for a waiver of this rule, on FCC Form 757-B.)

## License privileges

Okay, you passed the exam, you got the license—now what can you do with it? That depends on which license.

The *Restricted Radiotelephone permit* is intended for operators only, and has limited usefulness. You are authorized to operate the following classes of stations: remote-pickup broadcast, land and ship maritime telephone, aviation, public safety (police and fire), industrial, land transportation (taxicab and trucking). You may not perform any servicing or maintenance of transmitters.

The holder of a *Radiotelephone Third-Class permit* may operate all of the preceding stations, plus instructional fixed TV stations, international fixed public stations (common carriers) and—with a broadcast endorsement—AM broadcast stations with power output of 10 kW or less and nondirectional antennas, and FM broadcast stations with power output of 25 kW or less. This permit does not allow any servicing or maintenance of transmitters.

A *Radiotelephone Second-Class license* permits operation of all the preceding (no broadcast endorsement required to operate broadcast stations), plus TV auxiliary and booster stations, and CATV relay stations. This license is also really useful in an electronics sense; it allows you to perform servicing and maintenance at the following types

(continued on page 71)



# 30 BASIC IC PROJECTS

Part 1 of 2 parts to help you learn how to work with IC components and their related circuits  
By R. M. MARSTON

HAVE YOU IGNORED INTEGRATED CIRCUITS in your construction projects as "too expensive" or "specialized"? Forget those ideas—cheap, plentiful IC's are here, and you can build many circuits with them.

A real winner is the Fairchild  $\mu\text{L914}$ —it costs less than a dollar. For your money you get 4 silicon planar 2N708 transistors and six resistors, all encased in an epoxy block roughly the size of a TO-5 case. The 2N708 transistors have an  $f_T$  (gain-bandwidth product) of 450 MHz.

The internal circuit of the  $\mu\text{L914}$  is shown in Fig. 1, and lead connections in Fig. 2. By juggling around the connecting leads and maybe adding a few extra components, you can come up with: a differential amplifier, a multichannel audio mixer, or an audio oscillator, just to name a few examples.

Remember just two basic rules:

- (1) Do *not* think of an IC as some fantastic new technical device needing new application techniques all its own.
- (2) Do think of the IC as a bunch of perfectly normal transistors and resistors, bonded together in a single block, and requiring perfectly normal transistor-circuit design techniques.

With Rule 2 in mind, take a look at Fig. 1, the internal circuit schematic

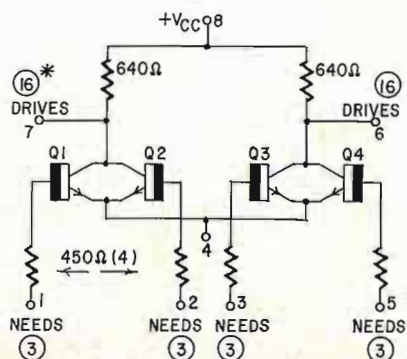

\*FIGURES INDICATE NUMBER OF "GAIN UNITS"—SEE TEXT

INTERNAL CIRCUIT OF  $\mu\text{L914}$

Fig. 1

of the  $\mu\text{L914}$ . Unwanted transistors can be effectively cut out of the circuit by shorting them base to emitter.

Cut Q2, Q3 and Q4 out of circuit by shorting pins 2, 3, 4 and 5. Wire a bias resistor from pin 1 to pin 7, and you're left with a perfectly normal common-emitter amplifier, Q1. Short out only Q2 and Q3, and apply bias to Q1 and Q4, and you have two normal common-emitter amplifiers.

Cut Q3 and Q4 out of circuit, and apply bias to Q1 and Q2. Now you have a two-channel mixer with output at pin 7. Apply bias to all four transistors and short pins 6 and 7, and the IC works as a four-channel mixer.

As you can see, it's easy to wire the  $\mu\text{L914}$  to work in a number of alternative basic modes. Once you've figured out which mode you want, you can get on with circuit design just as if you were using standard transistors.

Want to use the  $\mu\text{L914}$  in pulse or logic applications? A nice feature about this micrologic line of IC's is that you don't have to figure input and output drives in terms of impedance and current. Fairchild specifies input and output needs as so many *units of drive*, as shown circled in the diagrams.

Thus, the  $\mu\text{L914}$  needs 3 units of drive at each input and gives 16 units of drive at each output. Each output can therefore drive as many as five following input stages. This means that, if you want to use a stack of the circuits interconnected, you can easily

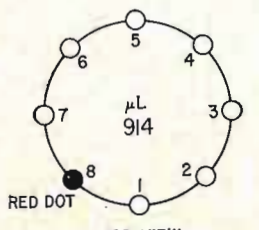

TOP VIEW  
BASE LEAD CONNECTIONS OF  $\mu\text{L914}$

Fig. 2

calculate just how many inputs each output can drive directly, and normally complex circuit layout calculations can be simply made.

Now let's look at some practical applications.

## Waveform generators

When the  $\mu\text{L914}$  is operated as a differential amplifier, one of the two outputs will be in phase with, but of greater amplitude than, the input signal. It follows that if this signal is fed back to the input the circuit will act as an oscillator or waveform generator. The waveform generated will depend on the form of positive feedback connection used in the circuit.

Fig. 3 shows how to connect the IC as a wide-range audio generator to cover 150 Hz to 40 kHz in three ranges. An approximately rectangular waveform is generated, since a simple RC (R6-C2) feedback network is used. R6 acts as the variable frequency control.

Fig. 4 shows the connections for making the circuit act as a 1-kHz Wien bridge sine-wave generator. The frequency-determining components are R1-C3-R6-C2.

When using this circuit R6 should be adjusted to give a pure sine wave on an oscilloscope. It is possible, using a 4.5-volt supply, to obtain a pure sine-wave output of about 1 volt peak to peak from the circuit. Note that the values used for C2 and C3 are not standard and must be built up by wiring standard components in parallel. The operating frequency can be changed, if required, by changing the values of C2 and C3; an increase in value gives a decrease in frequency.

## Dc meter amplifier

The differential amplifier is widely used as the basis of an electronic voltmeter or for increasing the sensitivity of moving-coil current meters. The trouble with normal transistors in these applications is that the circuits are subject to considerable zero drift with small changes in temperature. This is partly due to differences in characteristics of individual transistors. Another reason is that, due to its physical position in the circuit, one transistor may be subjected to larger temperature changes than the other.

When an IC is used as a meter amplifier, however, drift troubles do not exist. IC transistors are etched on a common slab of silicon and must inevitably be held at equal temperatures and have their characteristics closely matched as a result.

Fig. 5 shows how to wire the  $\mu\text{L914}$  for use as a dc meter amplifier. If a 1-mA meter is used, its sensi-

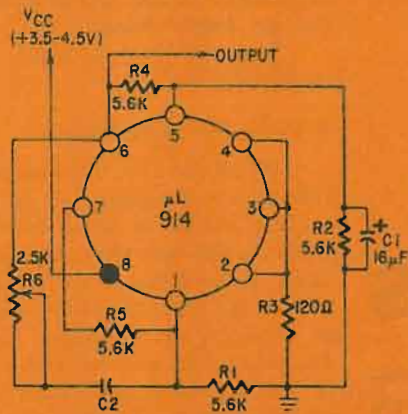

WIDE-RANGE AUDIO GENERATOR

C2 = 1μF, f = 150Hz TO 3kHz  
 = .1, f = 3kHz TO 15kHz  
 .02, f = 12kHz TO 40kHz

Fig. 3

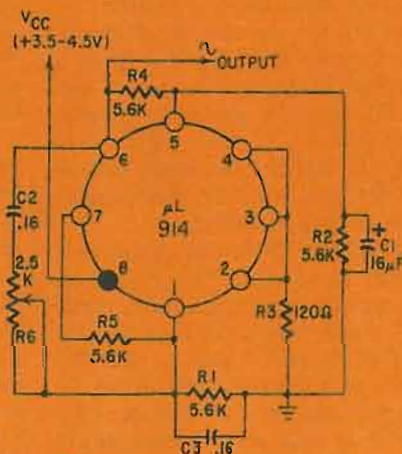

1kHz WIEN-BRIDGE SINEWAVE OSCILLATOR

Fig. 4

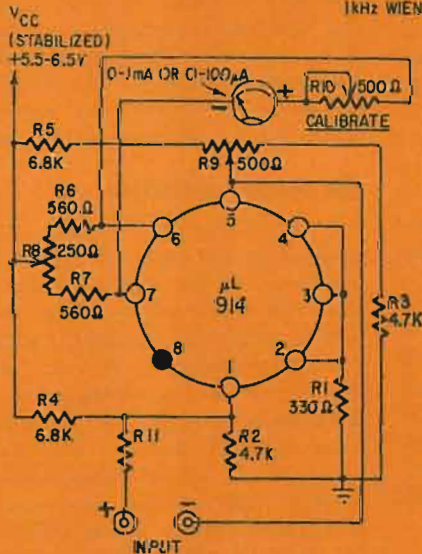

DC METER AMPLIFIER

R11 = VOLTMETER RANGE MULTIPLIER  
 = 20KΩ / VOLT FOR 1mA METER  
 = 100KΩ / 100μA METER

DC METER AMPLIFIER

Fig. 5

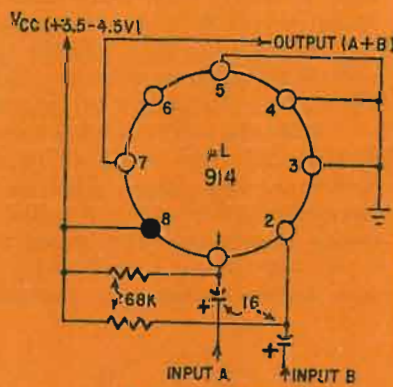

2-CHANNEL MIXER

Fig. 6

[The  $\mu$ L914 IC retails for \$0.80 at Fairchild distributors. Most of them do not accept mail orders for less than \$10.00. Semiconductor Specialists, P.O. Box 8725 O'Hare International Airport, Chicago, Ill. 60666 accepts mail orders of \$3.00 or more. If you must purchase by mail-order, we suggest you order four  $\mu$ L914's. They are quite versatile and you can use them in future construction projects.—Editor]

tivity will be increased more than 20 times (to 50  $\mu$ A). A 100- $\mu$ A meter can be increased more than 10 times (to better than 10  $\mu$ A).

If a voltage-range multiplier (R11) is wired in series with the input lead as shown, the sensitivity of the resulting electronic voltmeter will be raised to 20,000 ohms/volt using a 1-mA meter, and to 100,000 ohms/volt with a 100- $\mu$ A meter. Note that this circuit uses a 6-volt stabilized supply which can be obtained from a Zener diode.

Once the meter amplifier has been built, set it up as follows:

- Short the input terminals, and set R8 for a zero reading on the meter.
- Open the input terminals and set R9 for zero on the meter.
- Repeat (a) and (b) until no further zero adjustment is required.
- Select the multiplier (R11) for the full-scale voltage required. Example: If a 1-mA meter is used and a full-scale value of 10 volts is required, R11 should be 200,000 ohms.

(e) Apply a known voltage close to the required full-scale value to the input terminals and adjust R10 to indicate this voltage on the meter. The voltmeter is now ready for use.

When using the voltmeter, this series of checks should be repeated occasionally to make sure that calibration is correct. Readjustment will rarely be needed in practice, and R8, R9 and R10 can be preset types tucked away out of sight at the rear of the completed instrument. The unit may be used as a multirange voltmeter by providing switch selection of various R11 values.

### Mixer circuits

Since the  $\mu$ L914 contains two pairs of transistors sharing a common collector load, each pair of transistors can be made to operate as a two-channel audio mixer if the transistors are suitably biased.

Fig. 6 shows how to wire the IC as a two-channel mixer using the Q1-Q2 pair of transistors only, and Fig. 7 shows the alternative connection using



the Q3-Q4 pair. Both these circuits give a voltage gain of about 16, between each input and the output.

The  $\mu\text{L}914$  can be made to serve as a four-channel mixer by using both halves of the circuit and shorting all collectors to a common load. Fig. 8 shows the circuit. The voltage gain between each input and the output is about 8 in this mode.

### Emitter follower

You can obtain a normal emitter follower by using the connections shown in Fig. 9. Input impedance is about 12,000 ohms; it can be increased by using normal bootstrap techniques, if required. Only one emitter follower can be made from each  $\mu\text{L}914$ .

### Common-emitter amplifiers

The differential amplifier can be used with advantage to replace conventional common-emitter amplifier stages. The current taken by a C-E stage from the supply line remains virtually constant under operating conditions, and there is thus no great need to incorporate decoupling networks in the supply lines when cascading stages.

The  $\mu\text{L}914$  can, however, also be used to replace a conventional common-emitter amplifier. Fig. 10 shows one connection using Q1 only, while Fig. 11 shows an alternative connection using Q4. Both these circuits give voltage gains of about 20, and have flat frequency response within 3 dB from 60 Hz to well over 1 MHz.

The  $\mu\text{L}914$  connections can be modified so that the amplifiers of both Figs. 10 and 11 are incorporated in a single circuit, and two independent common-emitter amplifiers are made available. Alternatively, this modification can be made and the two amplifiers cascaded to form a single very-high-gain amplifier. The connections for this mode are shown in Fig. 12.

The circuit of Fig. 12 gives a voltage gain of about 400, and has a frequency response that is within 3 dB from 100 Hz to about 200 kHz. The low-frequency end of the spectrum can be extended by increasing the values of C1 and C2. Capacitors C3 and C4 limit the upper end of the frequency response; if they are not used, the circuit will, through internal feedback, act as an oscillator operating at a frequency of several megahertz.

Now that you've seen these first 10 applications of the  $\mu\text{L}914$ , you may want to try a couple. Next time we'll show you even more interesting uses for this inexpensive IC.

Continued next month

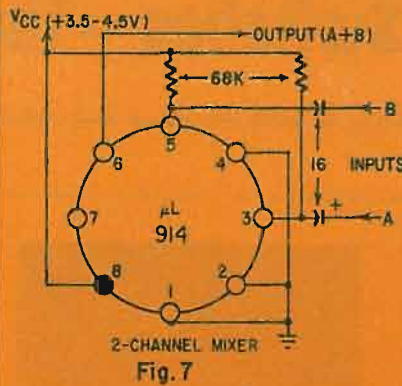

Fig. 7

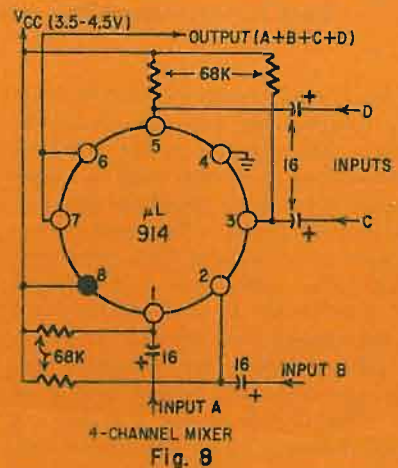

Fig. 8

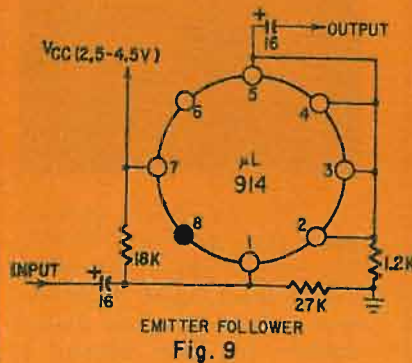

Fig. 9

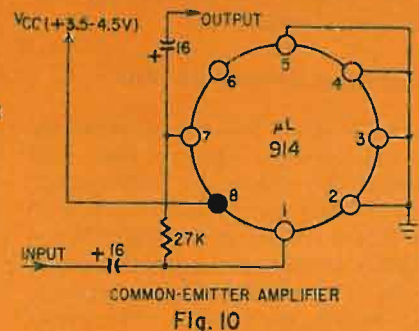

Fig. 10

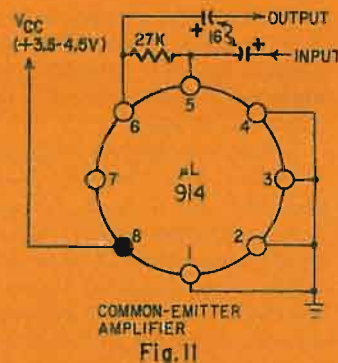

Fig. 11

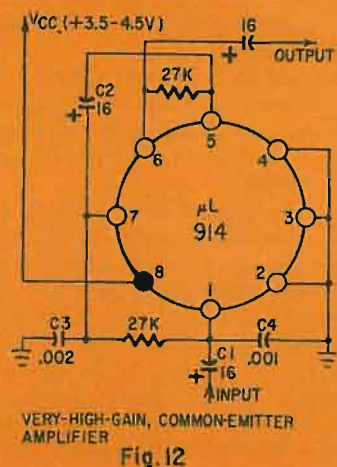

Fig. 12

# Rotary Stepping Switches—They're Everywhere

Part 2—Use them for counting, circuit selection and remote control

By TOM JASKI

PART I OF THIS SERIES DESCRIBED HOW rotary switches are used for the selection of as many points as the selecting switch carried, but with only a single sequence of pulses. A telephone dial is a useful control device which produces a maximum of 11 pulses. Thus supplying control pulses with such a dial might make it necessary to dial several times until the correct *total* number of pulses were delivered. Note too that most telephone-type dials will deliver one extra pulse. Thus if 3 is dialed, 4 pulses are actually delivered by an unmodified dial.

Fortunately, it's possible to prevent such action. An electrical modification can be made, by inserting a slow-release relay in the circuit. The relay is then picked up by the first pulse—the relay blocks all line pulses until it is picked up. It's also possible to modify the dial mechanism mechanically.

## Changing a telephone dial

Fig. 1 shows how to eliminate the extra pulse from a standard older-type telephone dial. Note the "off-normal" contacts. These are operated by a small brass foot attached to the shaft. When the dial is rotated, the normally closed contacts are opened (and the normally open contacts are closed). The pulses are produced by the interrupter as the dial is on the return stroke. By extending the brass foot of the off-normal contacts a little (this can be done by soldering on a small piece of brass) and sending the pulses through one of these contacts, the extra pulse can be eliminated. The last pulse is then blocked by the off-normal contact.

Note too that the dial's mode of forming pulses—making or breaking contacts—can be changed by adjusting the position of the interrupter cam on the geared shaft.

Using the dial for selection leads to a more sophisticated, two-level system. By using a switch of 10 points per level and 10 levels (Automatic Electric type 80, or equivalent), a 2-digit code can select any one of 99 points. Fig. 2 shows the diagram for such a selector system. S1 is a minor switch, operated by the first digit dialed; this action selects the *level* of S2. The next set of pulses then rotates S2 to the desired contact. As arranged here, the pulse line also becomes the control line, and the circuit resets



The Roto-Netic stepping motor from Heinemann Electric Co. converts pulses into rotary motion consisting of 10 precise steps. The device (see photo) consists of a linear solenoid, a spring-loaded, plunger-type armature, and a ratchet-and-pawl actuator on the end of the plunger that turns the output shaft.

When the solenoid is energized by a pulse, the plunger is drawn into the coil against spring tension. After the pulse, the solenoid is de-energized, and the spring forces the plunger back to "rest" position. This drives the actuator against a 10-tooth starwheel and produces 36° of shaft rotation (one step).

The actuator prevents the starwheel from rotating more than 36°, and a pawl prevents reverse rotation. This means there's no possibility of overshoot, and overshoot compensation isn't necessary. Each step is precisely the same as the last, and since the power stroke occurs upon de-energization, even the last stroke is recorded in case of power failure.

Speed is nominally 600 steps per minute and operates on either 12 volts dc or 115 volts ac with a bridge rectifier.

on a single pulse, but only after it has come to rest.

1CR is the relay which translates the pulses so a local power supply can be used. As pulses arrive, motor magnet MM1 steps S1 to the desired level of S2. Slow-release relay 2CR also energizes on the first pulse and remains energized until the pulses stop. When they do, and 2CR releases, relay 3CR is energized through now closed off-normal contacts ONS1 (which are on switch S1) and locks up on the supply. This action removes future pulses from S1 and also sends pulses through contacts 1CR-3 to motor magnet MM2. This second set of pulses causes MM2 to rotate S2.

When this sequence is finished, 2CR again drops out, now connecting 4CR, through 2CR-3, to the line and also to the wipers that make the controlled circuit. A tone arriving over this line does not affect the dc circuit, but a dc pulse will energize 4CR, a slow-release relay that will allow MM2 to step home on the interrupter and will energize the release magnet of S1, resetting these switches. Off-normal contact ONS1 on S1 then drops 3CR.

This circuit can deliver any one of 99 points on demand (even 100 by including the code 00). Using the same principles with more switches and relays would make it possible to extend the system indefinitely. Most industrial control or monitoring problems can be handled easily by a system that provides selection of any of 100 points—especially if the system has random access, like this one.

## Output pulse polarity

One point about generating pulses with a stepper: The circuit of Fig. 3-a produces negative pulses—i.e., no voltage during steps. Positive pulses—voltage *only during* steps—can be produced with the hookups of Fig. 3-b and c. At (b) the outgoing line is grounded as long as the switch remains on a contact; when the arm moves, a positive voltage goes to the line. The resistor prevents shorting the battery. At (c) a relay inverts the pulses.

The device of Fig. 4 has several functions. First, it counts pulses in decades from a switch-type transducer. By mounting numbered discs or cylinders on the switch shafts this count can be

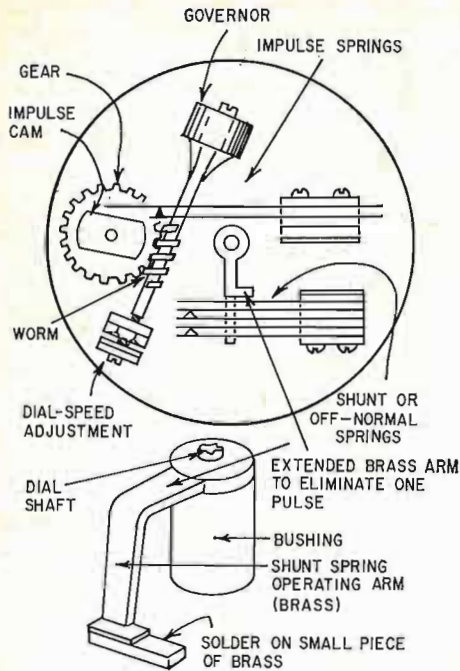

Fig. 1—How a telephone dial's shunt-spring operating arm is modified to eliminate the extra pulse that it normally generates.

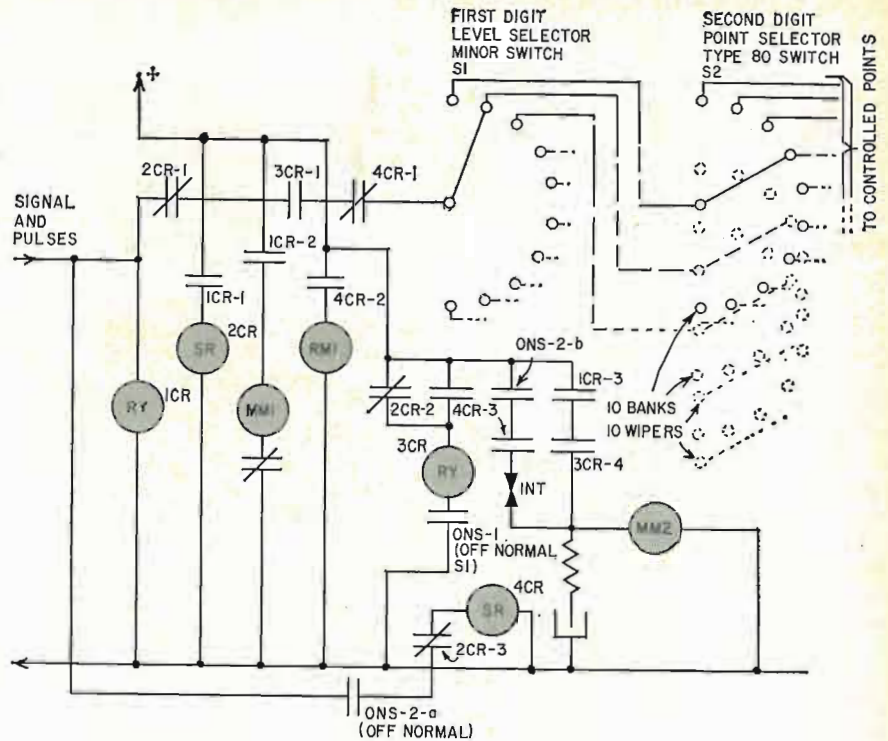

Fig. 2—A two-level selector can select any one of 99 points by actuating S1, then S2.

read directly. By supplying different tones for each switch, characteristic signals can be sent out over a single line, to identify units, tens and hundreds. (Of course, three separate lines can be brought out for this purpose.)

Circuit operation is simple: Incoming pulses operate relay 1CR, which is present for the usual reason (to keep

from loading the pulse line). It causes S1 to step, and on the tenth pulse to S1 causes a wiper contact to connect MM2 to the positive dc line. This starts S2 on its first step. This same wiper contact energizes relay 2CR, which resets S1. The next two steps operate similarly, and just one pushbutton resets the whole circuit.

Again it's possible to say that this circuit can be expanded to include "thousands," "ten thousands" and so on. For practical purposes a count of 999 is quite large. The circuit shown was used for registering gallons pumped by gas pumps in a service station. A remote register totaled all the data from the pumps, using a storage or "memory"

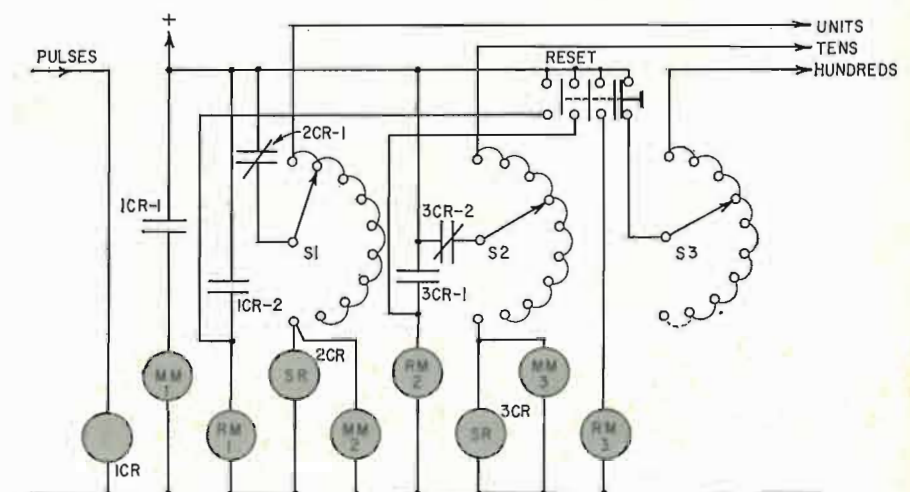
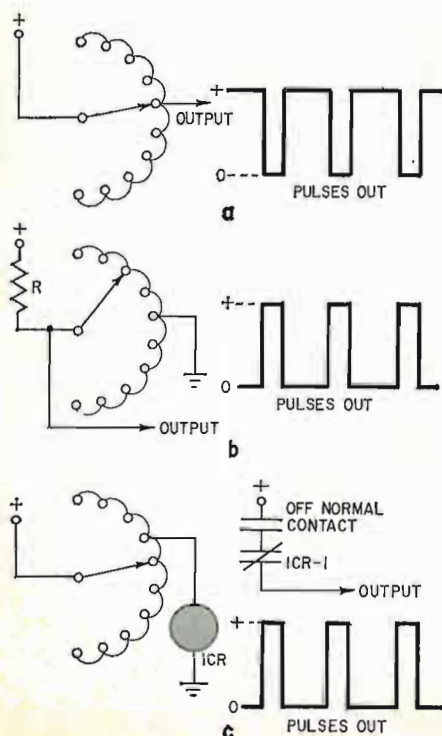

Fig. 4—(above)—Decade counting circuit. Separate lines send units, tens and hundreds pulses to readouts. Distinctive tone codes can be sent out over a single line.

Fig. 3—How stepper generates pulses. a—Negative (zero-voltage) pulse output when arm is between contacts. b—Positive-pulse generator. c—Relay ICR inverts pulses.

## Rotary Stepping Switches—They're Everywhere

circuit if several pumps were used simultaneously.

These circuits have been designed for direct-operated switches. For accurate timing it may make a difference whether switches are operated direct or indirect. An indirectly operated switch acts on the *cessation* of a pulse, rather than on the starting of one. In the circuits shown, that makes little difference. Also, all levels of contacts have been shown for nonbridging wipers. Bridging wipers running across contacts would not generate pulses.

Another point: A switch steps home much faster than it steps out, and pulses are produced by it much faster than dial pulses occur. (The latter run from 10 to 20 per second.) A switch stepping home on interrupters can be slowed down, as was described in Part I. But the homing speed of a minor switch can be regulated only by adjusting mechanical friction or spring tension. The speed can be slowed down some but not much.

### Storing numbers

The circuit of Fig. 4 can be used to store three digits (and more by extension). A simple readout can be built to show the final setting of the three switches. Such a readout arrangement is shown in Fig. 5. The banks at right of the diagram are one level each from the three minor switches of Fig. 4. The

stepping switch used for readout must be adjusted to make 30 contacts in sequence (on two levels), by properly setting the wipers. Each set of 10 is connected to the minor-switch contact banks. The switch will step through the first contacts (after starting, and this switch steps slowly) and will energize 4CR when a "ground" is encountered on the minor-switch bank. 4CR then stops further pulses (up to 10) from appearing on the output line.

When point 10 is reached, 4CR is reset by 2CR-3, and the switch then scans the bank of the second minor switch, and so on. The result is a series of three sets of pulses which will signal in order the units, tens and hundreds count of the three minor switches. If a pause is needed between sets of pulses, 2CR and 3CR can be used also to energize slow-operating relay 5CR. For the duration of its on-off cycle, 5CR prevents 1CR from stepping the switch. This function is indicated by dotted lines. The START button can be any momentary-contact type—even a relay contact.

For example, with several storage registers, a sensing circuit could be used to hold off one register until another has been "read." Any relay can be used as such a sensor by either the absence or presence of a voltage on its coil.

[In Fig. 5, the stepping switch is shown with two sets of 30 contacts ar-

anged in circles. Each set of 30 contacts has 3 wipers. The method of presentation is used for simplicity. Actually, each set of 10 contacts is on a separate level and the wipers are 120° apart. Thus, contacts 1 through 10 are on one level, 11 through 20 on the next, and so on. This switch—Automatic Electric type 44 or equivalent—accommodates up to six 10-point bank levels. It is driven by a 33-tooth ratchet providing 10 "on-the-bank" positions followed by an "off-the-bank" position for each one-third revolution.—Editor]

### Relay code selection

The individual code selector is a useful device. It can select one, and only one of several circuits, by means of one line or radio channel. While such selectors are made by various manufacturers (there are even electronics selectors with no moving parts), it's possible to build this kind of selector by using stepping switches and relays. Fig. 6 shows one circuit, which uses a type 44 switch, again arranged for 30 points.

Incoming pulses operate the slow-release relay and the motor magnet (the usual pulse relay has been left off). This switch, as shown has been arranged for the code 4-5-9. (Up to 0-9-9 can be used with the 44 switch.) If the switch wiper lands on any point connected to relay 2CR, the switch will immediately step home. Only by *successively* landing on the code-specified contacts will the  
*(continued on page 70)*

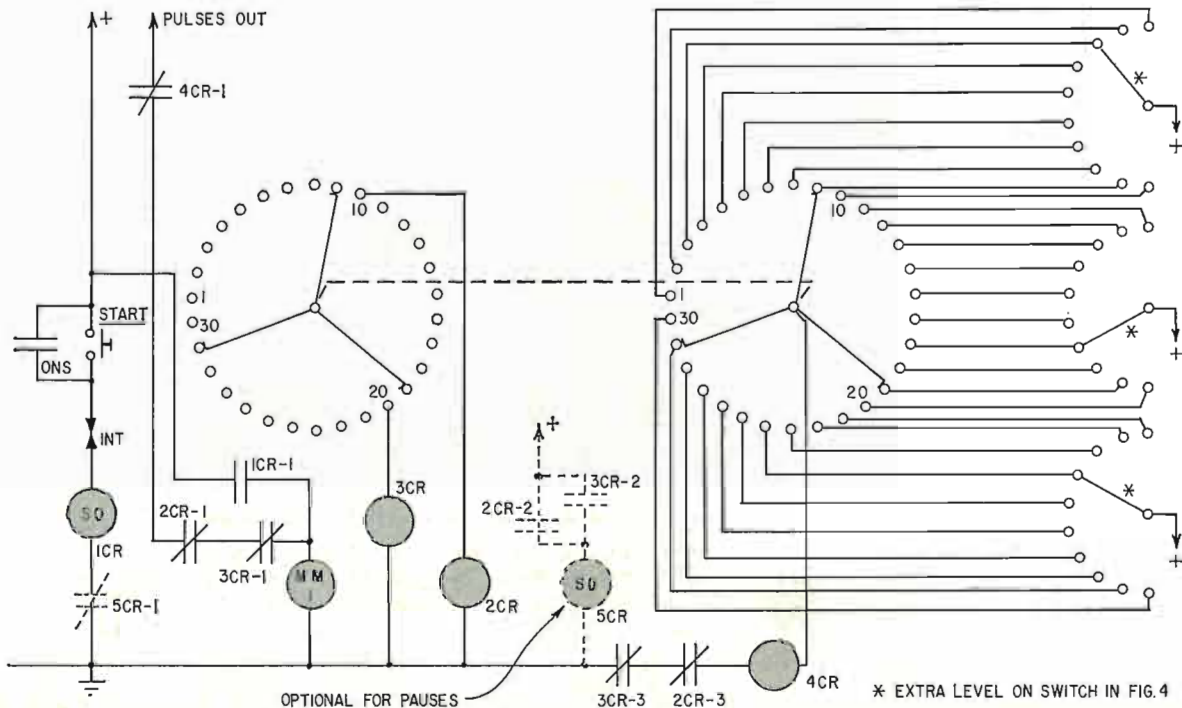

Fig. 5—Readout to indicate settings of switches in Fig. 4. An extra relay on contact 30 can replace the reset (START) switch.

# VERTICAL SWEEP MANUAL

Learn vertical sweep servicing as  
an expert analyzes typical problems.

## By HOMER L. DAVIDSON

VERTICAL SWEEP TROUBLES ARE EASY to spot. They appear on the screen as if to tell you exactly where to find them. If you know the functions of the vertical oscillator and output sections the visual symptoms can become most significant to you.

No vertical sweep shows up as a picture completely collapsed into a thin horizontal bright line. The line is usually bright because the energy of the electron beam that would normally be displaced over the full height of the screen is all concentrated in the line. Insufficient sweep shows up as a partially shrunken picture on top, bottom, or both. Nonlinear vertical sweep can cause heads to stretch or become flat-topped and feet to appear to be too long or too short . . . in severe cases the top and bottom of the picture folds over on itself.

Picture rolling can be caused by improper vertical oscillator frequency or loss of sync due to a weak signal, old age, poor video separation and other troubles in the video signal handling circuits.

### Vertical deflection circuits

There are three types of vertical-deflection systems, but only two are widely used. The oldest is the simplest to repair. It has a *blocking oscillator* and a vertical output stage as shown in Fig. 1. An integrating network keeps all pulses except vertical sync out of the vertical oscillator.

Take care when checking the voltage at the plate of the vertical output tube. The high-amplitude spikes can damage the meter. The best bet is to use a scope with an appropriate probe. If the waveshape is good and the amplitude correct, you can assume that the plate voltage is okay. Start at the vertical oscillator and proceed to the output stage.

Another method is to connect two pieces of flexible hookup wire to the

leads of a 0.05- $\mu$ F, 600-volt capacitor. Solder alligator clips to the free ends of the wires. You can check the vertical-deflection voltage by clipping an alligator clip to the center terminal of the volume control. Touch the other clip to the input and output of each stage in the vertical section. You will hear a 60-cycle buzz that will get louder as you progress toward the yoke. If the buzz drops off, you have located a trouble spot.

If you do not have a negative voltage on the blocking oscillator grid, the stage is not oscillating. Check the blocking-oscillator transformer windings with an ohmmeter. Many times the secondary is open. If it's okay, check the plate voltage and resistances. The vertical-output transformer's resistance should also be checked against the manufacturer's data. Also check to see that none of the transformer windings are shorted to the transformer core.

In many older TV receivers that come in for repair, the vertical hold control will move the picture only one way. The quickest [but not necessarily the best—*Editor*] repair here is just to change the vertical hold circuit. Simply tie a couple of clip leads to a 2.5-meg pot. Clip one to the vertical oscillator grid and the other to the top terminal of the hold control. Set the hold control in the center of its range and adjust the clipped-on pot until the picture rolls both ways when you turn the set's hold control. Now disconnect the pot and measure it. Solder in a 1-watt resistor of the closest 10% value.

The second kind of vertical-deflection system uses a *multivibrator*, and a vertical output stage. The third system is just like the second, only the vertical-output stage is part of the multivibrator. This third system is used quite extensively in newer TV receivers; in many, only one two-section tube is used, such

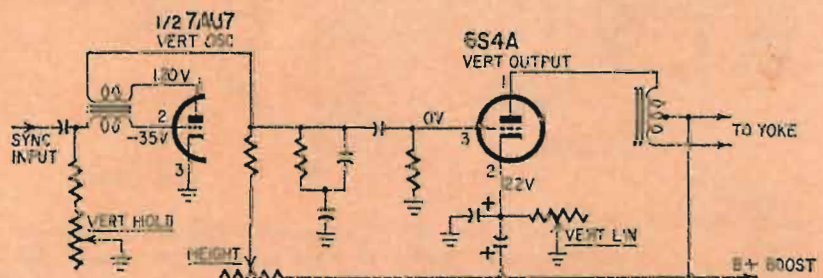

Fig. 1—A typical blocking-tube type vertical oscillator and output stage.

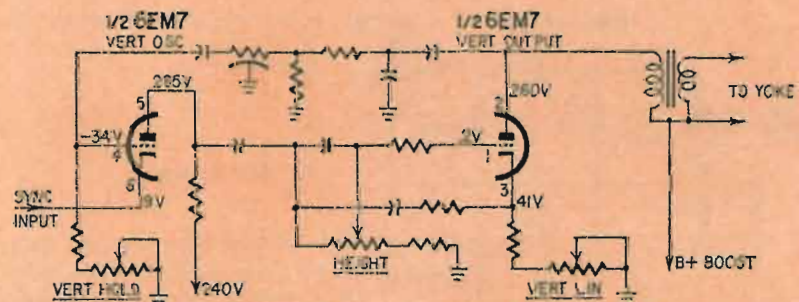

Fig. 2—The multivibrator hookup is a very popular vertical deflection system.

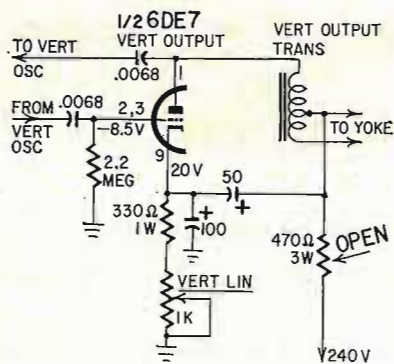

Fig. 3—The 470-ohm resistor opened, causing total loss of vertical sweep.

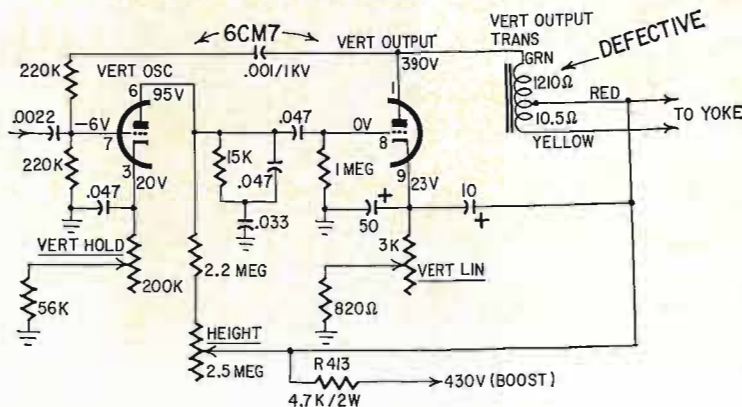

Fig. 4—Increase in transformer resistance cut pix height to 2 inches.

as a 6EM7. Fig. 2 shows a typical modern vertical-deflection system.

A multivibrator is a two-stage amplifier with the output of each stage fed to the input of the other. This positive feedback causes the circuit to oscillate. If any stage or a part of the feedback circuit becomes defective, the circuit will not oscillate.

#### Actual troubles

Let's take the case of only a horizontal line on the TV screen—let's say this is an Admiral 20US6 (Fig. 3). The brightness control should be turned

down so the line is just visible. Otherwise you can burn a line across the tube.

The 6DE7 tube was checked and found okay. The trouble was an open 470-ohm, 3-watt B+ dropping resistor.

This same trouble can also be caused by a feedback coupling capacitor at the plate of the output stage. There is a high peak voltage at this point and even the 1,000-volt capacitors usually used there can short or start to leak. A small Admiral portable, chassis 15UA2, came in with this trouble. The feedback capacitor had shorted, leaving only a white line on the screen. Replace such

capacitors with 1,600-volt types (the kind used as buffer capacitors in vibrator power supplies).

Another insufficient-height trouble was in an Admiral 14UY30 chassis (Fig. 4). There was only 2 inches of raster. Turning up the height control didn't help a bit. The output plate voltage was 200, and the grid voltage zero. The cathode voltage was only 11.5; it should have been around 23.

Most of the voltage, it turned out, was being dropped across the vertical-output transformer primary. A resistance check here showed that the winding had increased from 1,210 ohms to 1,580. The transformer was replaced, and we were in business. On this same chassis, I have found that R413 increases in resistance and causes the same trouble. Increased resistance in the height control or plate dropping resistor will cause the same symptoms.

#### Rolling picture

Many things can cause the picture to roll: insufficient sync, a defective integrator circuit, too-high resistance, leaky capacitors or some variety of intermittent. Let's take a look at a RCA KCS97D chassis (Fig. 5).

The vertical hold control had no effect on the rolling picture. This control didn't even seem to be in the circuit. Control open? Checked it. Nope. Wrong again. Voltages on the vertical-oscillator tube were quite close to what they should be. I just *knew* the trouble was in the vertical hold circuit. R153 checked 5.5 meg. It should have been 6.8, but that didn't seem to be too serious a difference.

The original complaint was intermittent vertical rolling. Now the set just rolled, period! Back to R153. I cut one end of the resistor loose and checked the resistance. Here was the trouble. The resistor was wide, wide open.

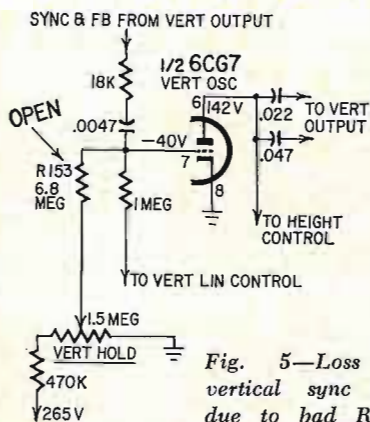

Fig. 5—Loss of vertical sync was due to bad R153.

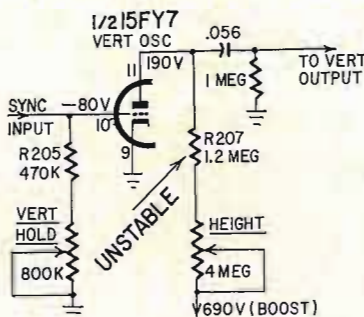

Fig. 6—R207 shifted with changes in temperature. This caused the picture to roll intermittently.

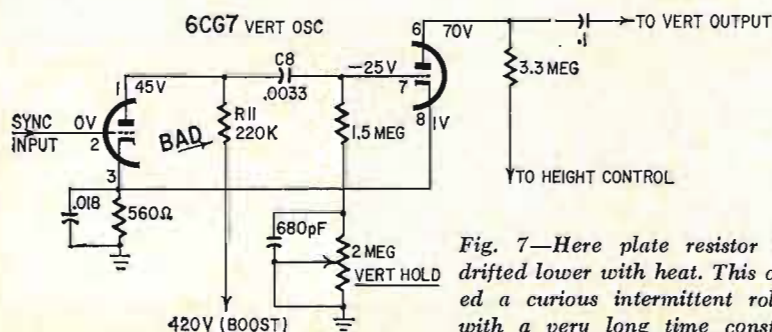

Fig. 7—Here plate resistor R11 drifted lower with heat. This caused a curious intermittent rolling with a very long time constant.



A case of severe nonlinearity at bottom of the screen. The cause is shown in Fig. 9.

(Sometimes it just pays to work a hunch.) The 5.5-meg reading? Shunt paths elsewhere in the circuit.

Now let's check some intermittent vertical-roll troubles. I had a G-E QX chassis (Fig. 6) that would be okay for about 2 minutes and then roll. I would set the vertical hold for a stable picture and within 5 minutes it was rolling again. That told me resistance values were changing or perhaps a capacitor was leaking.

When a picture rolls intermittently, the trouble is usually in the grid or plate circuit of the vertical-oscillator stage. Sometimes the trouble is in the cathode circuit, but usually the cathodes are grounded.

I measured the grid resistor, R205. It was off by a bit, so I replaced it, but to no avail. Finally I came to R207, a 1.2-meg resistor. As the set warmed up, its resistance changed. Replacing it solved the problem.

You will find that many intermittent vertical-roll troubles can be traced to the oscillator plate resistor. If you have any doubts, replace it. A change of resistance in the vertical hold control or the height control can cause vertical rolling.

The main trouble from height controls is a burned spot. When you try to increase the height, the raster collapses to a few inches. Always remember: the height control affects the bottom of the picture most, while the linearity control has its main effect at the picture top.

Another rolling trouble, in a Philco model 9L60U (Fig. 7). Here more time elapsed between rolls. This set wouldn't roll until after it was on for 1½ hours. I could reset the vertical hold control and again the picture would sit still for an hour or two. Great! To top it, when the back was removed the set wouldn't roll at all!

I pulled the chassis, set it on the bench and checked all the tubes. They were okay. Heat seemed to figure in the trouble. I tried a new 6CG7 vertical tube, just in case. I put the set back in its box. Sure enough, in about 2 hours

the same trouble appeared. Capacitor C8 was replaced because it was a little leaky. Still the set rolled after a couple of hours.

R11 seemed quite warm. It measured 220K. The next time the set started to roll, I jerked the line plug out and clipped out one end of R11. It now read 150K. R11 was changing with heat. I should have followed my own advice: "Replace the plate load when in doubt."

### Odd vertical troubles

After this Silvertone model 45-528.51680 receiver was on a few seconds, the raster was only about 3 inches high and quite jittery. It bounced. Of course the vertical tube was the first thing checked. It was okay. The grid voltage was off a little and the plate voltage on pin 5 was only 50 (Fig. 8). According to the service data, I should have had 90. The height control and the 1-meg series resistor were checked; they were good. Something was leaking and pulling that voltage down.

I pulled the vertical tube and checked its plate voltage. (You have to do this very rapidly in a series-heater receiver, because of course the other tubes go out when one is pulled.) Here I found only the same 50 volts; I should have been getting the full voltage at the height control.

I checked C30 for leakage; it was good. C29 showed some leakage. When

I cut one end, I measured 100K across it. Replacing the capacitor restored the full raster.

In many sets, a jumping raster is caused by a defective vertical-output transformer. This is especially true in old, long-used sets.

This next case looked like vertical linearity trouble. The bottom of the picture had wider scanning than the top line did. This is shown in photo at left.

It was an Admiral model UP9808 (Fig. 9). Someone else had attempted to repair the set, for the thermal relay had been shorted out. Sometimes the picture looked like it was suffering from vertical bunching, but this proved not to be the case. All voltages in the vertical circuit were checked, and they all seemed fine.

After searching the vertical section for trouble, I traced the B+ wires back to the power-supply filter. I found after a little browsing that the silicon rectifier had been replaced. Something didn't add up. The B+ line that fed the vertical and horizontal circuits came directly off the rectifier. It should have gone first through the filter choke.

The B+ wire to the horizontal and vertical circuits had been removed and hadn't been resoldered to the correct point. This goes to show that the poor helpless television receiver may have, not only its own troubles, but a few extras put in. **R-E**

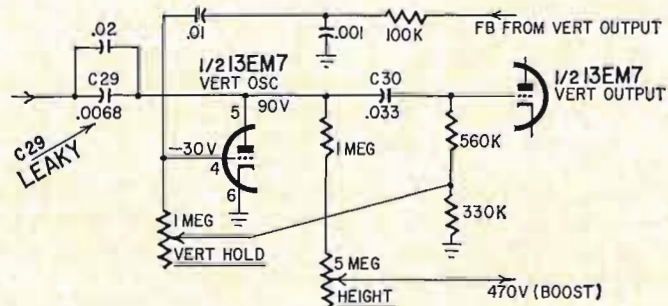

Fig. 8—Leakage in C29 upset the normal operation of the vertical multivibrator and produced a bouncing 3-inch high raster.

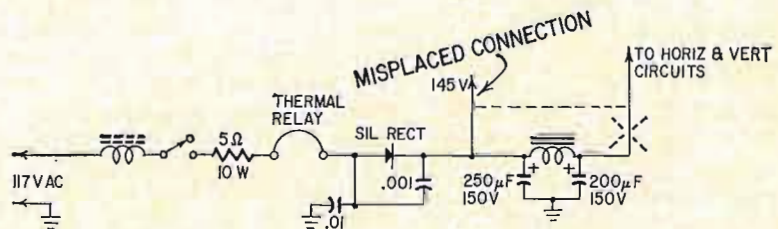
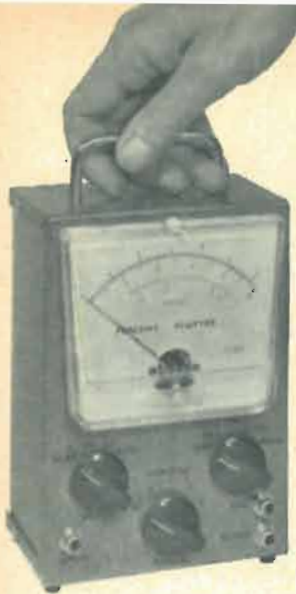

Fig. 9—Nonlinearity developed after a careless technician inadvertently bypassed the pi-network filter after replacing the silicon rectifier.



# A Compact, High-Performance Flutter Meter

Useful in servicing tape recorders, this meter  
can measure tape-travel inaccuracy of less than 0.1%

By EARL T. HANSEN

IS YOUR TAPE RECORDER AS GOOD AS IT was when new? As mechanical parts wear, slight speed variations can cause a degradation of recorded tapes; the fault becomes progressively worse as tapes are copied. This meter will let you make easy, periodic measurements of such signal degradation, to help you avoid poor recordings.

This meter uses the latest solid-state components, including an integrated circuit and an FET. Battery operation keeps the cost down, provides portability, and—most important—eliminates 60-Hz hum pickup from the ac line.

Alignment and calibration require only a vtvm and an audio oscillator, though a scope and an ac voltmeter will assure greater accuracy.

Flutter consists of undesirable and relatively rapid changes in pitch of recorded and reproduced sound. It is caused by irregular mechanical motion during recording or playback of tape, disc or film. Per cent flutter is defined as the rms deviation from the average frequency as a percent of that average frequency.

Flutter meters normally detect flutter rates from 0.5 Hz to 120 Hz; some even go up to 200 Hz, if intended for measurements of motion-picture equipment.

(Undesirable but relatively slow changes in pitch are known as *wow*; frequency variation is typically 0.5 Hz to 5 Hz. *Wow* occurs principally in disc recording and playback, so we aren't concerned with it here.)

## How it works

The basic idea for most flutter meters is to use some kind of FM discriminator or detector. Proper limiting to remove amplitude modulation is important—just as in an FM receiver. The signal from the discriminator is filtered to remove the audio carrier frequency and to limit the range of flutter rates. The rms value of the sig-

nal is then measured by a high-sensitivity ac vtvm with extended low-frequency response.

A commonly used frequency for flutter tests is 3 kHz; the frequency was chosen many years ago for motion-picture use, when sound-system response barely reached 5 kHz. This meter uses 5 kHz as a test frequency for several reasons. The discriminator could be more easily designed around readily available components. The higher carrier frequency allows measurement of higher flutter rates and simplifies the required filter.

In this meter (Fig. 1) an inexpensive integrated circuit makes an ideal amplifier and limiter. The IC contains 10 transistors, a voltage regulator, and those resistors necessary to complete a three-stage amplifier. Because of the internal regulator, changes in battery voltage have minimum effect on the limited output amplitude (a 5-kHz square wave) which drives the discriminator coils. The IC has very high gain and will saturate with 30 mV at input jack J1.

Minimum input level should be 0.1 volt, to lessen the effect of tape dropouts. Diode D1 protects the IC against possible damage by an external voltage overload.

A 5-kHz signal is fed to input jack J1 and then through limiter IC1. Output from this stage is a square wave, which goes through isolating resistors R6 and R7 to the discriminator. The discriminator consists of tuned circuits L1-C5 and L2-C6, and associated components. One circuit is tuned to 4 kHz, the other to 6 kHz. Each drives a voltage-doubling rectifier (or peak-to-peak detector). Diodes D2 through D5 are polarized so as to have opposite dc polarity at the output; positive from the L1 side, and negative from the L2 half.

When the voltages induced in the coils are equal (at approximately 5 kHz) the dc outputs will be equal

## BENCH



## TESTED

Two RADIO-ELECTRONICS editors used this flutter meter to check out a medium-quality tape deck. Following the author's instructions, we recorded the 5-kHz test signal at

7½ ips. Then we played back the tape and read flutter on the meter. Our average for several measurements was about 0.1%, within specifications for the tape deck. At 3¾ ips, the machine had about 0.15% flutter. By rapidly jabbing a finger against the tape or the capstan during playback, we could artificially increase flutter to over 1% as read on the meter.

A reader using the author's calibration tape should *not* rewind it in the normal inanner, as this might stretch the tape and alter its calibration. Instead, reverse reels and run it back at "play" speed.

and opposite in polarity; thus they cancel to zero at the junction of R8 and R9. When the input frequency changes toward either 4 kHz or 6 kHz, the ratio of the voltages in the two halves of the discriminator will not be equal and the dc at the junction will change. Fig. 2 shows the frequency-vs-output curve for the discriminator, as measured at the source of Q2.

Note that the voltage is 2.85 rather than zero at the middle frequency. This is a result of two voltages which are added to the discriminator output. One is the difference in potential across FET Q2 (gate to source). The other is the result of the discriminator return being connected to pin 3 of IC1. This is a convenient source of approximately 2 volts forward bias on the FET (which acts as a source follower); the bias sets the correct operating point on the FET transfer curve for handling larger voltage swings.

A three-section RC filter between the discriminator and Q2 removes any remaining 5-kHz carrier, and deter-



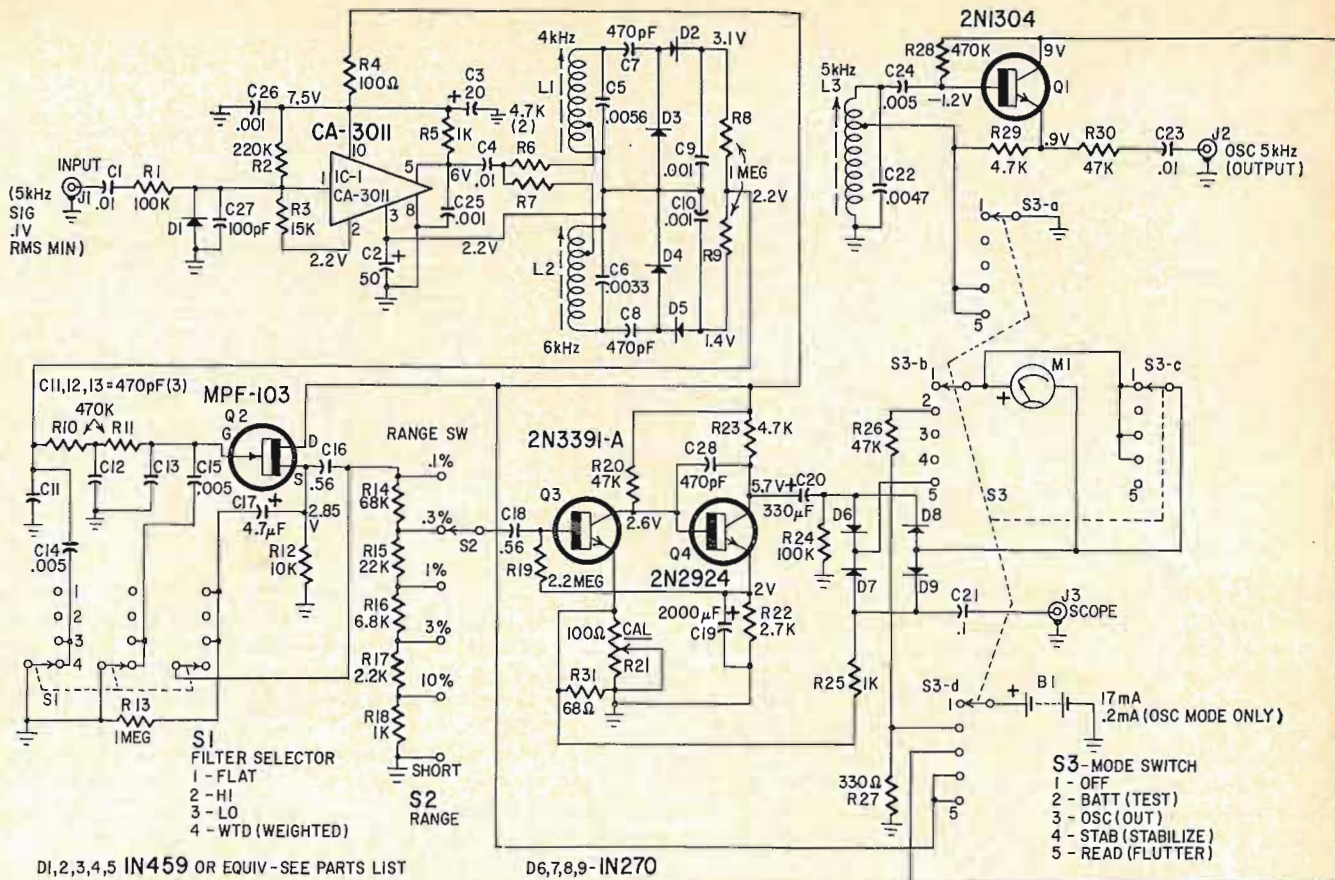

D1,2,3,4,5 IN459 OR EQUIV - SEE PARTS LIST

D6,7,8,9 - IN270

VOLTAGE READINGS TAKEN IN STAB MODE WITH 5kHz INPUT SIGNAL. EXCEPT Q1 IN OSC OUT MODE

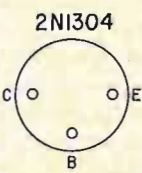
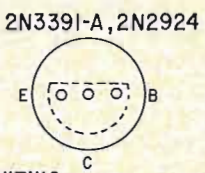
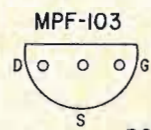
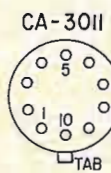

BOTTOM VIEWS

Fig. 1—Sine-wave input signal is fed to IC1, which produces square-wave output. Discriminator (L1-C5, L2-C6) furnishes error voltage to amplifier Q2. Voltmeter section (Q3-Q4) reads this error as flutter produced by the tape recorder tested.

**Flutter Meter Specifications**

- Ranges: 0.1%, 0.3%, 1%, 3%, 10% full scale rms
- Input level: 0.1 volt rms minimum for good limiter saturation
- Input frequency: 5kHz, ±5%
- Battery: 9 volts, NEDA 1602
- Battery drain: 0.2 mA in OSC mode, 17 mA in all other modes
- Internal OSC output: 5kHz, 4 volts rms unloaded, with less than 5% distortion
- Internal noise: The residual reading due to the combined effects of internal oscillator FM variations and random noise is less than 0.001% flutter
- Stabilization time: 30 seconds after power on, or 5 seconds after applying signal input
- Flutter rate bandwidth: FLAT (filter switch position), 0.6 to 200 Hz, ±3 dB
  - HI, low-frequency rolloff, down 6 dB at 1.5Hz
  - LO, high-frequency rolloff, down 6 dB at 35 Hz
  - WTD (weighted filter position) combines the rolloff of the HI and LO filters

**Parts List**

- R1, R24—100,000-ohm resistor
- R2—220,000-ohm resistor
- R3—15,000-ohm resistor
- R4—100-ohm resistor
- R5, R25—1000-ohm resistor
- R6, R7, R23, R29—47000-ohm resistor
- R8, R9, R13—1-megohm resistor
- R10, R11, R28—470,000-ohm resistor
- R12—10,000-ohm resistor
- R14—68,000-ohm, 5% resistor
- R15—22,000-ohm, 5% resistor
- R16—6800-ohm, 5% resistor
- R17—2200-ohm, 5% resistor
- R18—1000-ohm, 5% resistor
- R19—2.2-megohm resistor
- R20, R30—47,000-ohm resistor
- R21—100-ohm miniature potentiometer (Mallory MTC or similar)
- R22—2700-ohm resistor
- R26—47,000-ohm, 5% resistor
- R27—330-ohm resistor
- R31—68-ohm resistor
- All resistors 1/4-watt or more, 10%, unless otherwise noted
- C1, C4, C23—0.01-μF paper or ceramic capacitor
- C2—50-μF, 6-volt electrolytic capacitor
- C3—20-μF, 10-volt electrolytic capacitor
- C5—0.0056-μF mica capacitor
- C6—0.0033-μF mica capacitor
- C7, C8, C11, C12, C13, C28—470-pF ceramic capacitor
- C9, C10, C25, C26—0.001-μF ceramic capacitor
- C14, C15, C24—0.005-μF ceramic capacitor
- C16, C18—0.56-μF tantalum capacitor (Kemet C series or similar)
- C17—4.7-μF, 10-volt, tantalum capacitor (Kemet C series or similar)
- C19—2000-μF, 10-volt, electrolytic capacitor
- C20—330-μF, 10-volt, tantalum capacitor
- C21—0.1-μF paper or ceramic capacitor
- C22—0.0047-μF mica capacitor
- C27—100-pF ceramic capacitor
- All capacitors 20 volts, or more, unless otherwise noted
- IC1—Integrated circuit amplifier, RCA CA3011
- Q1—Germanium npn transistor, 2N1304
- Q2—N-channel junction field-effect transistor (Motorola MPF-103 or similar)
- Q3—Silicon planar npn transistor (G-E 2N3391A or similar)
- Q4—Silicon planar npn transistor (G-E 2N2924 or similar)
- D1, D2, D3, D4, D5—Small-signal silicon diode, 1N-459 or similar
- D6, D7, D8, D9—Germanium diode, 1N270
- J1, J2, J3—Phono jack
- S1—3-pole, 4-position, shorting rotary switch (Centralab 1012 or similar)
- S2—1-pole, 6-position shorting rotary switch (Centralab 1000 or similar)
- S3—4-pole, 5-position shorting rotary switch (Centralab 1012 or similar)
- L1, L2, L3—78-240-mH tapped inductor (Miller 9018 or similar)
- B1—9-volt battery (NEDA 1602 or 1605; see text)
- M1—200-μA meter, scales 0-3 and 0-10 (Heathkit 407-85 or similar. Available from Heath Co., \$10.40 plus postage)
- Misc.—3" x 5" x 7" metal box (Bud CU-2108A or similar); perforated board, push-in terminals, handle, knobs, wire, and small hardware

Note:—A 3" reel of calibration tape is available for \$2.40 postpaid, from E. T. Hansen, 3361 Millcreek Rd., Salt Lake City, Utah 84109. Instructions are included.



Fig. 2—Discriminator output curve. Circuit converts frequency shift to dc.

mines the desired curve for the flutter-rate frequency response. Figure 3 shows the curves for the four settings of filter switch S1. As a source follower with a gain of less than one, Q2 matches the very high impedance of the discriminator and filter to Q3.

Transistors Q3, Q4 and associated components constitute a feedback-stabilized ac voltmeter. Large coupling and bypass capacitors—C20 and C19—extend the low-frequency response to the required range. Feedback ratio (and therefore gain) is adjusted by the calibration control, R21. Resistor R25 develops a voltage proportional to meter current, which allows the actual flutter waveform to be observed on an external oscilloscope via J3. Approximately 0.5 volt peak to peak appears at J3 with full-scale meter deflection.

### Construction

I would suggest a slightly larger metal box than the one I used, unless you are concerned about size. Assembly will be easier if things are not so crowded. Many small components can be mounted on the switches; mount the others on a perforated board with push-through terminals (see Figs. 4, 5 and 6). Coils L1 and L2 should be separated by at least 1½" to avoid interaction; location of L3 is not so critical though, since it is shorted out during the READ mode. Leads on the ceramic capacitors which bypass pins 1, 5 and 10 of IC1 to ground should be kept as short as possible. Otherwise the IC may oscillate at some rf rate.

The tap location on the coils is important. On L1 and L2 the taps are nearest the ends which go to pin 3 of IC1. On L3 the tap is farthest from ground. The unused pins (4, 6, 7 and 9) on IC1 may be snipped off to minimize congestion. If you do use a larger case I would suggest the next size larg-

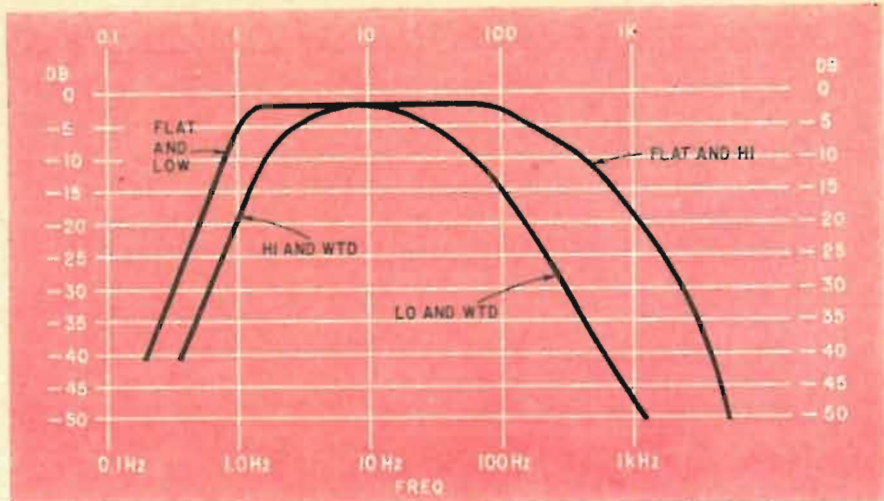

Fig. 3—Filter output curves for the four positions of filter selector switch S1.

er battery (NEDA 1605). It has a longer life at about the same cost.

In case you want to substitute, component types are not critical except as follows: Q1 must have at least a 10-volt emitter-base rating. Switches should be the shorting type to avoid transients. Q3 and Q4 must be high-gain, low-leakage silicon-planar types. Q3 should be a low-noise type.

### Test and calibration

Connect a milliammeter in series with the battery and make sure that the current is not excessive. It should be zero in the OFF position, about 0.2 mA in the OSC position, and about 17 mA in the other positions. The test current in the BATT position depends on the value of R27.

Apply a 1-volt, 5-kHz signal from a sine-wave audio generator to the input, J1, and set S3 to the STAB position. There should be a square wave on pin 5 of IC1. The waveform should be about 2.4 volts peak to peak and will be tilted. Set the generator to 4.0 kHz. Connect the hot lead of a dc vtm to the junction of D2 and C9, with the common lead to ground. Adjust L1 for maximum reading on the vtm. Next set the generator to 6.0 kHz and adjust L2 for *minimum* positive voltage at the junction of D5 and C10. Set S3 to the osc mode and monitor the output at J2 with a scope or audio amplifier. Set the generator to 5.0 kHz and compare the frequencies, audibly, or preferably with the scope. Adjust L3 so the output at J2 is 5 kHz.

Measure the dc voltages on Q3 and Q4. The collector voltage on Q4 should be between 4.5 and 7. If it is not, the value of R20 should be changed slightly. Increasing R20 will increase the Q4 collector voltage and vice versa. If it is necessary to go above 100,000 ohms for R20, Q3 has low gain and should be changed. This

completes everything except the actual calibration adjustment (R21).

As a start, adjust R21 for a reading of 38 ohms from Q3's emitter to ground—with the flutter meter turned off, of course. At this point the meter will be accurate enough for most home comparison-type measurements. This includes correction for the 0.707 factor described below in the section on using the meter.

For a more accurate calibration proceed as follows: The end accuracy will depend on the accuracy of your equipment, the audio generator, the dc vtm and the ac voltmeter. Connect the dc vtm to the Q2 source (junction of R12 and C16). Set the audio generator to 4.5 kHz, 1 volt out, connected to J1, and set S3 to STAB. Read the voltage with both 4.5-kHz and 5.5-kHz inputs (one at a time). Note the difference between the two readings; it will be 1.4 volts typically. This difference is equivalent to a peak-to-peak frequency swing of 20%, or half the difference is equal to the peak frequency swing of 10%. Therefore an rms voltage equal to the difference would be equivalent to 10% rms swing (or flutter).

Set the generator to 20 Hz. Connect the generator output to the top of the range switch (junction of R14 and C16). Then set the range switch to 10% and set S3 to READ. Measure the audio amplitude from the generator with the ac voltmeter and adjust it to an rms value equal to half the dc difference voltage noted above. As an example, if the difference measured above is 1.46, set the generator output to 0.73 volt rms.

Adjust R21 until the flutter meter reads full scale (10%), if you desire a true flutter reading, or do as I did and adjust R21 until the meter reads 7.07%. This will let you make measurements without factoring when re-

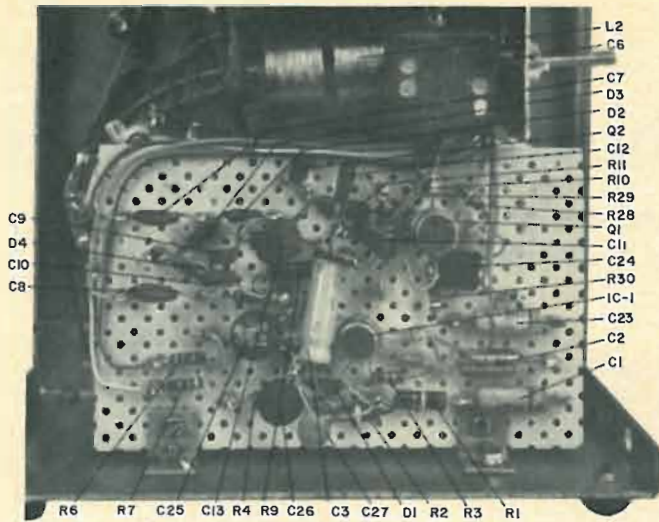

Fig. 4—Limiter-discriminator layout is easily done on board.

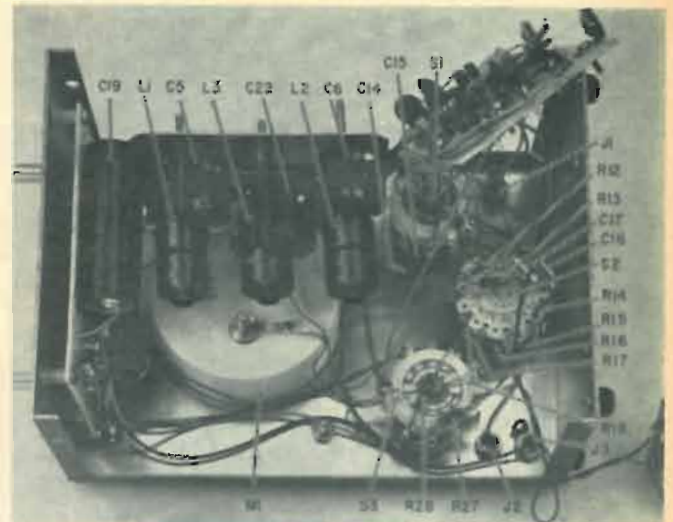

Fig. 5—Coils are mounted on a bracket beside meter movement.

ording and playing back. Otherwise factoring is necessary to compensate for the flutter created by both the recording and the playback of a tape.

The cover on the metal box must be in place before using high-sensitivity positions of the range switch, to avoid stray pickup.

An alternate and more accurate method of calibration is to obtain a calibration tape. See the parts list.

#### Using the meter

The mode switch has four active positions. BATT measures the battery voltage with a resistive load equal to the normal meter drain. OSC operates only the internal 5-kHz oscillator, which is available at J2 for recording onto a tape. The recorded 5-kHz signal is then played back into the flutter meter to obtain a reading. STAB is the stabilize position, used prior to taking a reading. In this position the meter is shorted out until the long time constants in the ac voltmeter circuit become stabilized; otherwise the meter would bang the peg a time or two. The READ position gives a meter reading of the flutter amplitude.

Battery voltage has a negligible effect on accuracy until it drops below 7.5. The battery should be changed when it drops to 8 volts, as indicated on the meter in BATT position. Useful life of the NEDA 1602 battery is about 40 hours of intermittent use, except for the OSC mode, which is very much longer.

There are two methods of measuring flutter in sound equipment. One (known as the standard method) uses a standard recorded reference, that is a tone (carrier) recorded on a tape (or disc or film) with a flutter content very

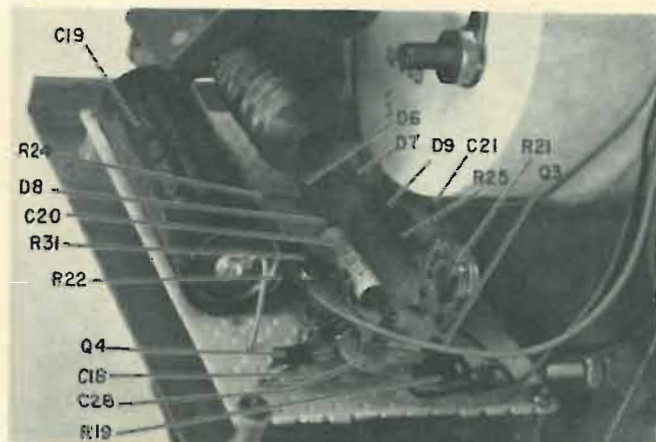

Fig. 6—Voltmeter circuit is also mounted on perforated board.

much less than that of the equipment to be tested. By this method the flutter content can be obtained directly from the meter without factoring, or rerunning to get an average. The flutter meter described here can be used for this method. However, standard tapes with low flutter content are very expensive.

The second (or nonstandard) method is to record a tape from a very stable source (such as the oscillator built into this meter) and play it back through the meter. This method has one drawback: the recorder adds flutter to the tape during recording and again during playback. The two flutter conditions will add vectorially, and readings can vary considerably, depending on the phase and regularity of the two sources. Generally the resultant will be greater than either of the two sources alone. The generally accepted practice is to take the average of several readings and multiply it by 0.707 to obtain a true flutter measurement. The 0.707 factor has been included in the calibration of this meter

and need not be considered when making measurements.

It is good practice to average several readings. Rewind the tape slightly between each reading to change the recorded flutter to machine flutter/phase relationship. Fig. 7 shows typical flutter viewed on a scope.

When recording the carrier (5 kHz) on a tape, use the maximum record level. The amount of distortion will have no effect on the flutter content. Record several minutes of the carrier so there will be plenty of time for meter stabilization and multiple readings.

The filter switch gives a choice of flutter-rate response characteristics. The FLAT position has maximum bandwidth and reads flutter at its worst. The HI position removes very low flutter rates—as might be caused by an off-center reel—and therefore helps to isolate the source and type of speed variation. The LO position removes the higher frequencies—which might origi-

(continued on page 60)

# BUILD

## A Professional Quality Transmitter Monitor

Solid-state and vacuum-tube versions of a handy rf watchdog for hams, CB'ers and commercial operators

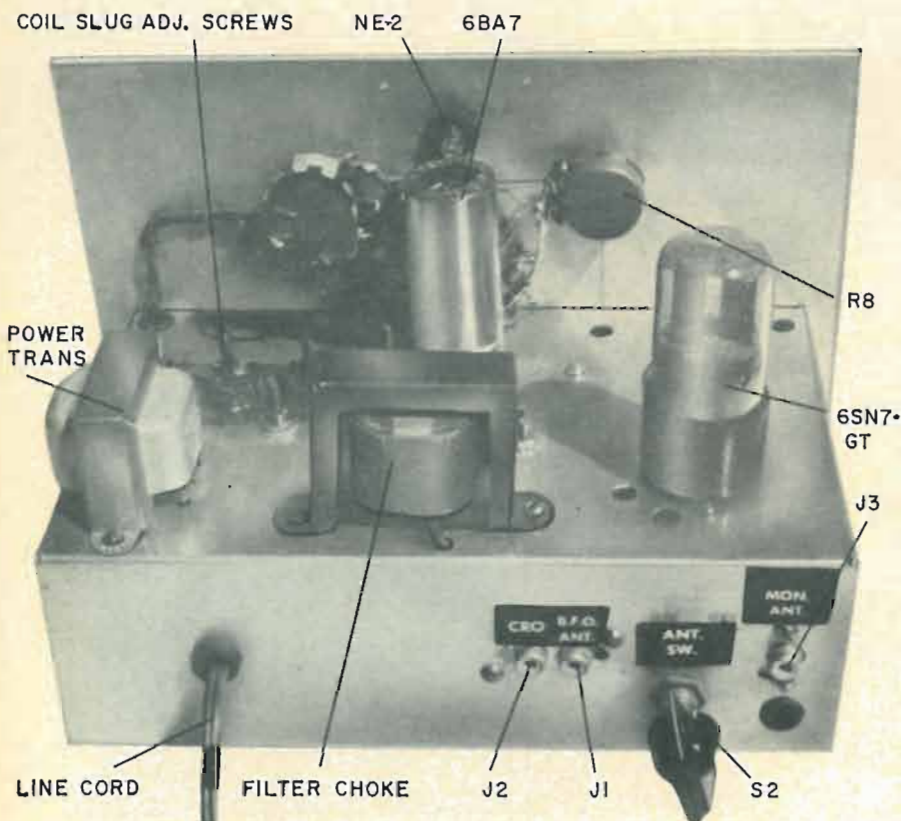

By J. P. NEIL

ANYONE WHO OPERATES A RADIO STATION—amateur, CB or commercial two-way—will find an rf monitor useful. It enables you to keep tabs on the transmitter while operating. The ones described here don't require any physical connection to the transmitter itself. Here's what each does:

1. Permits continuous visual and aural carrier on-off monitoring; has relay contacts to operate external alarm (solid-state version only).
2. Acts as CW keying monitor. (*Note:* Does not warn of key clicks or CW hum.)
3. Demodulates an AM signal for quality check of audio.
4. Supplies rf output to drive an oscilloscope. You can then observe either trapezoid or envelope waveforms to check percentage of modulation.

### General description

Block diagram, Fig. 1, illustrates monitor function. Rf is fed through a

beat oscillator and mixer and a low-pass filter. The filter output (below 1 MHz) is split, appearing on terminals for scope display, and being fed to the carrier-alarm circuit (solid-state version only). The carrier-alarm circuit triggers a relay, the contacts of which may be used to operate an external alarm.

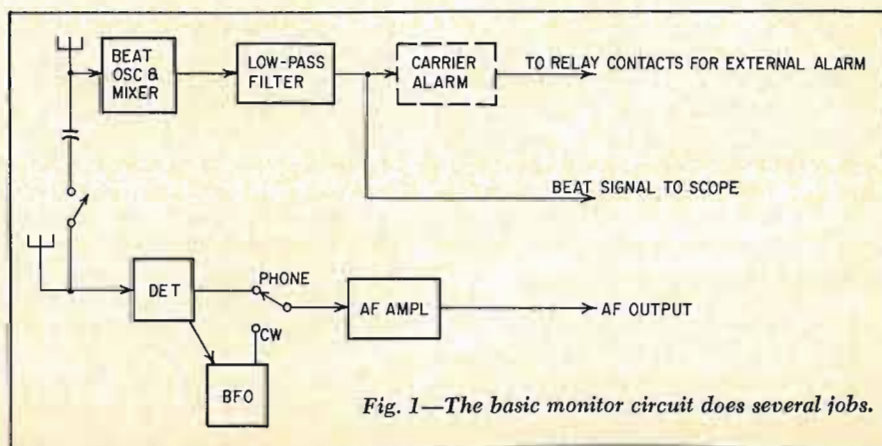

Fig. 1—The basic monitor circuit does several jobs.

Rf is also fed to a detector, a bfo and an audio amplifier. These circuits provide monitoring and quality checks of CW keying and AM modulation.

### Circuit details

Figure 2 is the schematic of the solid-state version, which operates as follows: if a pickup antenna is used at J3, closing S4 will usually produce enough rf drive to operate the alarm circuit. If this is not the case, a separate antenna may be connected to J1. Whichever jack is used, rf travels through RF GAIN pot R1 and C4, then to the base of Q1. This transistor works as both an oscillator and a mixer, its frequency being determined by the particular LC tank selected by S1. All oscillator coils are slug-tuned to about 355 kHz above or below the transmitting frequency in the selected band. C6 is a panel adjustment for trimming the beat frequency.

In the alarm circuit, L2 and C9 resonate at about 355 kHz, so C6 is adjusted for maximum signal at the base of Q2. Depending on the relay used, Q2 will operate with about 10 or 15 mA. It should be heat-sunked if the monitor will be used continuously in the carrier-on mode.

The keying- and modulation-monitor section uses diode D to rectify incoming rf. For CW monitoring, Q3—a tone generator—acts as a bfo which is switched on and off by transmitter keying. For AM modulation monitoring, demodulated rf from D is fed through S5 to Q4 and Q5. These stages are direct-coupled, npn to npn. J4 is a closed-circuit jack; normally the speaker is used

**Parts list for solid-state model**

- R1—1000-ohm potentiometer (including S3—s.p.s.t. switch)
- R2—15,000-ohm resistor
- R3, R9—10,000-ohm resistor
- R4—1800-ohm resistor
- R5—20,000-ohm potentiometer
- R6, R10—100-ohm resistor
- R7—50,000-ohm potentiometer
- R8—91,000-ohm resistor
- R8—470-ohm resistor
- C1, C2—(See coil table)
- C3—5-pF capacitor
- C4, C5, C7, C11, C13, C15, C19—0.01- $\mu$ F capacitor
- C6—25-pF variable capacitor
- C8, C9—20-pF, silver mica capacitor
- C10—470-pF capacitor
- C12—0.22- $\mu$ F capacitor
- C14, C16, C17—25- $\mu$ F, 25-volt, electrolytic capacitor
- C18—0.02- $\mu$ F capacitor
- C19—100- $\mu$ F, 25-volt, electrolytic capacitor
- C20—0.05- $\mu$ F capacitor
- C21—0.5- $\mu$ F capacitor
- J1, J2, J3—Phono jacks
- J4—Closed circuit phone jack
- L1—1-mH rf choke (J. W. Miller 4652-E)
- L2—10-mH rf choke (J. W. Miller 4672-E)
- L3—2.4-mH rf choke (J. W. Miller 4666-E)
- D—1N4009 diode
- Q1, Q4—2N2924 transistor
- Q2—2N696 or 2N169 transistor
- Q3—2N1617, 2N2160 or 2N2646 transistor
- Q5—2N1415 transistor
- S1—2-pole 6-position rotary switch
- S2, S4, S6—S.p.s.t. toggle or slide switch
- S3—(See R1)
- S5—D.p.d.t. toggle switch
- SPKR—2" or 3" speaker, 4-ohm coil
- T—Output transformer: 500-ohm primary, 4-ohm secondary
- RY—Relay: 50–500-ohm coil resistance, 10–15-mA operating current. Contacts N.O. or N.C., as desired.
- BATT 1—battery, 12 volts
- BATT 2—battery, 9 volts

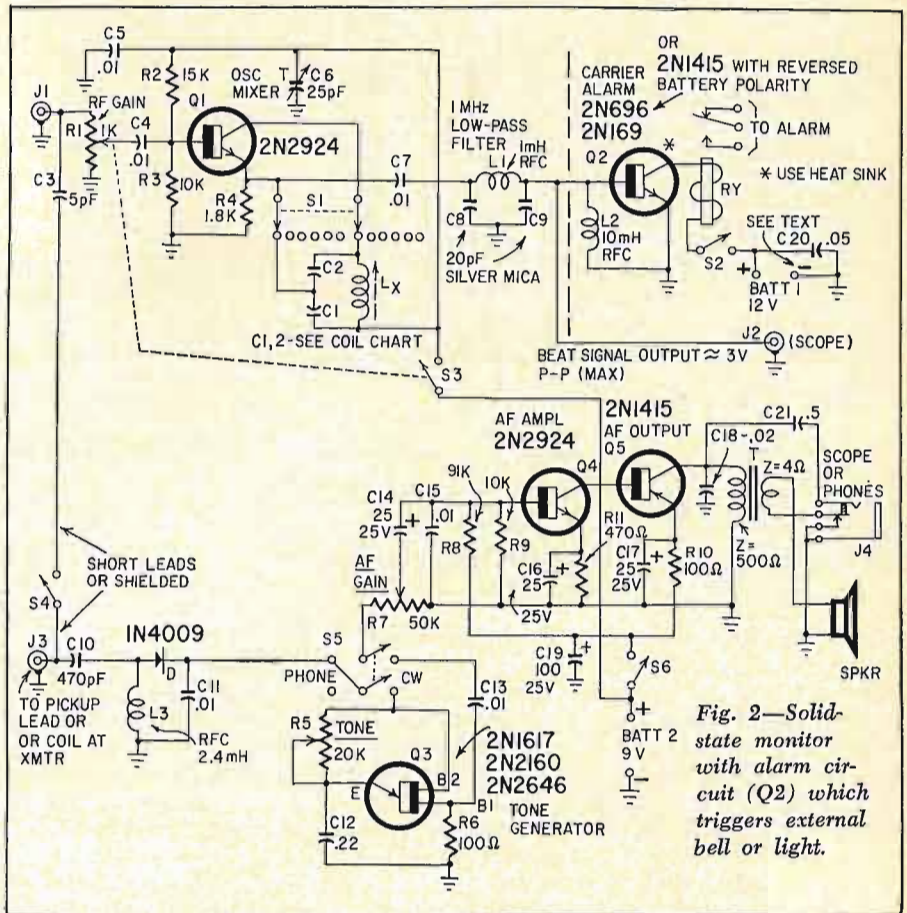

**Fig. 2—Solid-state monitor with alarm circuit (Q2) which triggers external bell or light.**

**Parts list for vacuum-tube model**

- R1—1000-ohm potentiometer (including S3—s.p.s.t. switch)
- R2, R6—10,000-ohm resistor
- R3, R5, R14—27,000-ohm resistor
- R4—150-ohm resistor
- R7—1500-ohm resistor
- R8—1-megohm potentiometer
- R9, R11—1-megohm resistor
- R10—47-ohm resistor
- R12—47,000-ohm resistor
- R13—2-megohm potentiometer
- R15—100,000-ohm, 1-watt resistor
- C1—5-pF capacitor
- C2, C14, C17—220-pF capacitor
- C3—50-pF capacitor
- C4, C15—0.005- $\mu$ F capacitor
- C5, C9, C10, C12, C13, C18—0.01- $\mu$ F capacitor
- C6—25-pF variable capacitor
- C7, C8—20-pF capacitor
- C11—10 $\mu$ F, 50-volt, electrolytic
- C16—0.002- $\mu$ F capacitor
- C<sub>x</sub>—See Table 1
- All capacitors 400v unless noted
- J1, J2, J3—Phono jacks
- J4—Phone jack
- S1—2-pole 6-position rotary selector switch
- S2, S5—S.p.s.t. toggle or slide switch
- S3—(See R1)
- S4—D.p.d.t. toggle switch
- D—1N4009 diode
- T—Output transformer: 10,000-ohm primary to 4-ohm secondary
- L1—1mH rf choke (J. W. Miller 4652-E)
- L2—2.4-mH rf choke (J. W. Miller 4666-E)
- L<sub>x</sub>—See Table 1
- V1—6BA7 tube
- V2—12AU7, 6SN7-GT or similar tube
- PL—6.3-volt pilot lamp
- NE—NE-2 neon lamp

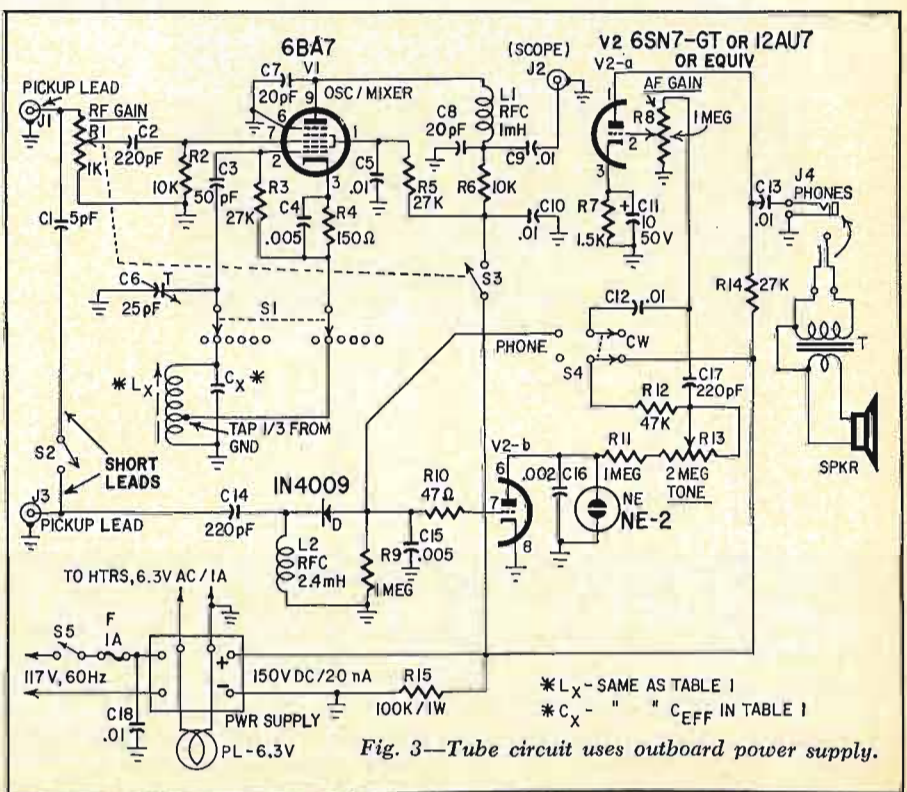

**Fig. 3—Tube circuit uses outboard power supply.**

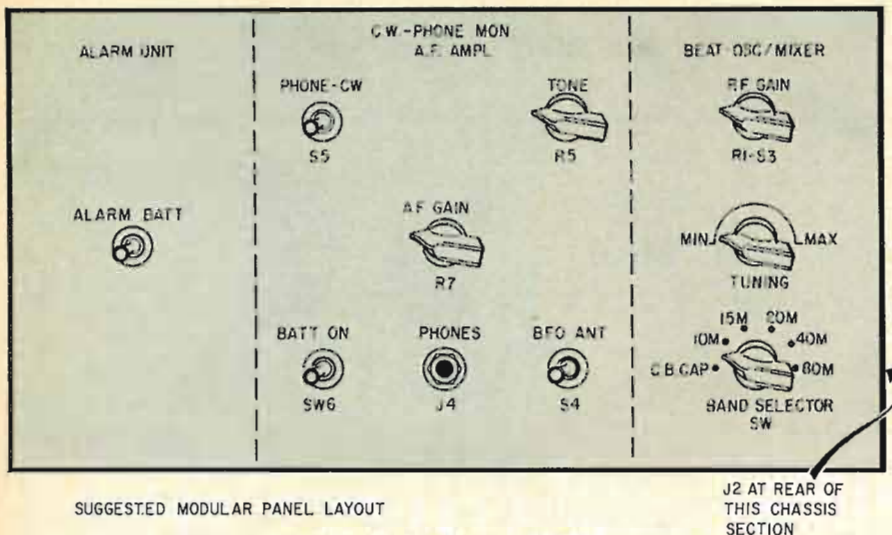

Fig. 4—Panel layout is not critical . . . position parts to fit without crowding.

### Build a Professional Quality Transmitter Monitor

for CW monitoring while only the phones are used on AM. Thus the speaker is killed and feedback is avoided, where the monitor is used near the transmitter microphone.

Note that Q3 requires no power supply; it operates from incoming rf. Q5 takes most current from the battery, but it operates class AB. Hence the total drain of Q4 and Q5 will be from only 2.9 to 5.2 mA, depending on audio level.

The vacuum-tube model operates the same as the solid-state model. There is no carrier-alarm circuit, but it would not be difficult to build one using a thyatron and a plate relay. As before, C6 must be adjusted to resonance, and the easiest way is by tuning to peak the waveform observed on a scope at J2. There is also no power supply, but requirements are small: 6.3 Vac at 1 amp and 150 Vdc at 20 mA. Note that the 6BA7 should be shielded.

### Assembly and setup

It's up to the user whether to build the monitor on a conventional chassis or a printed-circuit board. The solid-state version is easily constructed on a perforated board, while the vacuum-tube unit goes best on a standard chassis. A suggested panel layout is shown in Fig. 4 and the photo.

Values listed in the coil table cover the bands listed, all tunable with C6. Use the coil slugs to set operating frequencies, and trim with C6.

To adjust the carrier alarm in the solid-state version, first couple rf into the monitor by a pickup antenna connected to J3 or J1. Adjust R1 and C6 for maximum current through the relay coil. Don't overdrive the transistor. Monitor the current with a vom and if Q2's rating is exceeded, you may have to drop the battery voltage with a divider.

In the monitor section, R5 adjusts

Coil table

Band	Freq. (MHz)	L <sub>x</sub> (μH)	C <sub>eff</sub> (pF)	C1 (pF)	C2 (pF)	L <sub>x</sub> (turns)	Wire Size
80 m	4.05	8	200	600	300	26	N. 24 dcc
40 m	7.35	5.4	100	300	150	20	"
20 m	14.355	2.5	50	150	75	10*	"
15 m	21.455	2.0	50	150	75	7½*	N. 18 enam.
CB/CAP	27.3	0.7	50	150	75	6*	"
10 m	29.5	0.6	50	150	75	5*	"

\* Equally spaced turns

Coils are wound on 3/8" diameter forms with 3/4" winding length. Slug core material for 1-30-MHz service. (J. W. Miller type 21A000RB1, Cambridge Thermionic LS3 series or similar.)

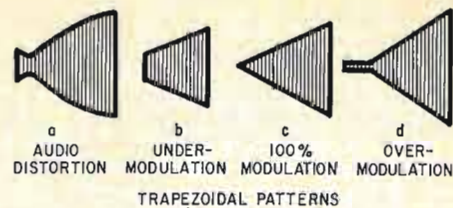

Fig. 5—Trapezoid waveforms you'll see on your scope when checking AM transmitters.

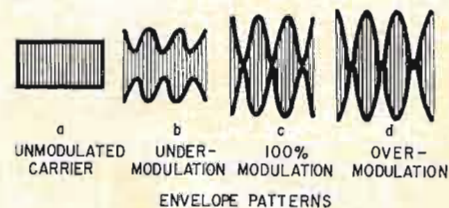

Fig. 6—Envelope modulation patterns.

the keying-monitor tone, and R7 sets AM-monitor gain.

To check the percentage of modulation of a transmitter with a scope you must modulate the rig with a single-frequency tone, preferably from a good-quality audio generator. To obtain a trapezoid pattern: Connect the scope vertical input to J2. Set horizontal gain at minimum. On the monitor, set R1 at maximum and adjust C6 for maximum vertical trace on the scope. Set the scope vertical gain to fill about one-third of the screen, and connect the horizontal input to J4, switching the horizontal input selector to the EXTERNAL position. Adjust horizontal gain to about one-third or one-half full. Set S5 to PHONE position and adjust audio gain with R7 until horizontal sweep just about fills the screen.

You'll find one of the traces shown in Fig. 5 on the scope screen. If there's distortion, it may be occurring due to overload in the monitor or the scope. Reset R1, R7 and the scope vertical gain control to see if this eliminates the distortion. If it doesn't, the transmitter is probably at fault.

It's simpler to obtain the envelope patterns of Fig. 6. You need only take the output from J2, feeding it to the scope vertical input. If the transmitter is modulated with a 1,000-Hz tone, adjust the scope horizontal sweep rate to 250 Hz and you'll see four cycles on the screen. If the peaks of the modulated envelope are flattened, there's distortion somewhere.

Low-priced scopes generally have limited frequency response, and won't show much of a trace of rf above 1 MHz. The monitor circuits described here beat the transmitter frequency down to below 1 MHz, where it can be easily displayed by nearly all scopes. **R-E**

## BUILD

# A Two-Way, Two-Way Lamp

Let there be more light this Christmas

By BYRON G. WELS

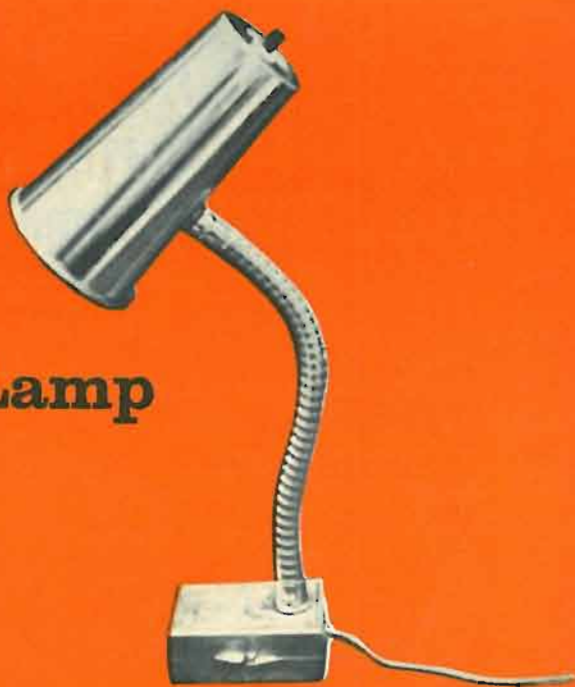

DOUBLE TALK? NOT REALLY. THIS lamp does double duty in two ways. For one thing, it's a high-intensity lamp with a "two-speed" control. In the first switch position, the lamp is off. In the second position it is about half bright; in the third position, the lamp is fully bright—and don't get the idea that you need an automobile lamp to get high intensity, either!

It's also two-way because this lamp can mount either on its base like any other lamp or (because the base is filled with small magnets) you can mount it on any ferrous metal surface.

As the diagram shows, a three-position switch is used. This gives you OFF (no current to lamp), HI (full current) and LO (half current). In the LO position, a silicon rectifier conducts only on every other half-cycle of the ac voltage, thus reducing current drain (and lamp brightness).

While you can purchase all the materials new, you may wish to modify an old lamp or salvage some parts from your scrap box to keep the costs down.

### Construction tips

I mounted the switch on the base of an aluminum tumbler, and cemented the lamp socket to the switch. You'll want to use a s.p.d.t. pin switch with wire leads. Start by mounting the back of the switch on the base of the lamp socket. Use RTV cement to hold it in place, and allow it to set overnight.

Next align the magnets so they aid rather than repel each other, and place them in the bottom of the plastic

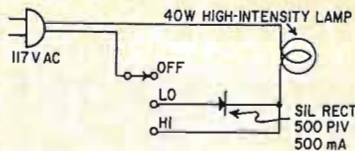

*Silicon rectifier reduces lamp intensity by allowing current to flow only 50% of the time. Its polarity is not important.*

### Materials List

- 1—High-intensity lamp, 117 volts, 40 watts (G-E 40 S11N/1 or similar)
- 1—Socket to fit lamp
- 1—S.p.d.t. pin switch, 117 volts (two on positions, one off position) with leads
- 1—Silicon rectifier diode, 500 piv, 0.5 amperes
- 1—Ac line cord and plug
- 1—Anodized aluminum cup or tumbler
- 1—Flexible gooseneck, about 10" long by about 3/4" diameter
- 1—Plastic or nonferrous metal box, about 3" x 2" x 1"
- 1—Tube of Dow Corning RTV 732 Silastic cement or similar

Several small, strong magnets (old speaker magnets will do)

**Note:** You can obtain the diode, the ac line cord and plug, the plastic or metal box, and possibly the magnets, at an electronic parts house. You'll probably have to get the lamp, socket, switch and gooseneck at an electrical supply house or hardware store, where you can also obtain the Silastic cement. Magnets are also available from Edmund Scientific Co., Barrington, N. J. 08007.

or nonmagnetic metal box used as a base. You can use RTV cement generously to hold the magnets in the box. A double layer of magnets will give the base added gripping power.

Locate the center of the bottom of the drinking cup or tumbler and drill a 3/8" hole for the switch. Make another 3/8" hole on one side to support the gooseneck. Placing the gooseneck closer to the open lip of the cup will not only make for a more artsy-craftsy look, it will also make the nut on the end of the gooseneck easier to tighten and give you more working room inside.

Make a final 3/8" hole in the top of the plastic or metal box to mount the other end of the gooseneck. Now snake the line cord up through the box and gooseneck; pull out plenty of slack from the front of the cup, which is now your lampshade.

Following the wiring diagram, connect the switch, lamp socket and line cord. Carefully wrap all exposed leads with plastic electrical tape (or shrinkable tubing). Now insert the switch through the hole in the back of the shade, and fasten it in place with its nut. The switch is now supporting the socket as well. Pull the excess wire back through the bottom of the box and, with your soldering gun, make a small indentation in the plastic to allow the line cord to pass. If you use a metal box you'll have to drill a hole for the wire.

Try the lamp . . . if it works paint it gold or any other color to go with your room decor. **R-E**

Get Top **PERFORMANCE** from  
your Car! **Buy The Best!**



**DELTA'S Remarkable, Proven**

# MARK-TEN CAPACITIVE DISCHARGE IGNITION SYSTEM

ONLY  
**\$44.95**  
ppd.

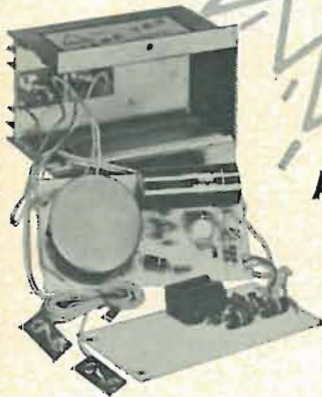

Available in Easy-to-Build

## DELTAKIT®

ONLY

ASSEMBLE IT  
YOURSELF!

**\$29.95**  
ppd.

You've read about the Mark Ten in Radio Electronics, Electronics, World, Mechanix Illustrated, Electronics, Popular Mechanics and other leading publications! Now discover what dramatic improvement in performance with capacitive discharge ignition is yours for your car, truck, jeep, boat — any vehicle! Delta's remarkable electronic achievement — on the market since 1963 and so unique that a patent has been granted — saves on gas, promotes better acceleration, gives your car that zip you've always wanted. Even Detroit has finally come around. Delta's Mark Ten, the original, the proven winner from Sebring to Suburbia, has set new records of ignition benefits attested to by thousands of satisfied purchasers. No re-wiring necessary. Works on literally any type of gasoline engine. Satisfaction guaranteed.

Order from coupon below, specifying car make, voltage and polarity. Like to build your own? Order a Deltakit® and save!

### COMPARE THESE PROVEN BENEFITS!...

- ▲ DRAMATIC INCREASE IN ACCELERATION
- ▲ LONGER POINT AND PLUG LIFE
- ▲ IMPROVED GASOLINE MILEAGE
- ▲ MORE COMPLETE COMBUSTION
- ▲ SMOOTHER PERFORMANCE

Order Your Mark Ten Today! Shipped Postpaid at Once.



## DELTA PRODUCTS, INC.

P.O. BOX 1147 RE — GRAND JUNCTION, COLORADO 81501

Enclosed is \$ \_\_\_\_\_ Ship prepaid.  Ship C.O.D.   
 Mark Tens (Assembled) @ \$44.95  Mark Tens (Deltakit®) @ \$29.95  
(12 volt positive or negative ground only)

Specify  6 Volt: Negative Ground only.  
 12 Volt: Specify  Positive Ground  Negative Ground

Car Year \_\_\_\_\_ Make \_\_\_\_\_

Name \_\_\_\_\_

Address \_\_\_\_\_

City/State \_\_\_\_\_ Zip \_\_\_\_\_

## HIGH PERFORMANCE METER

(continued from page 55)

nate with motor torque variations—and again helps to isolate a problem.

The WTD position gives a weighted measurement. The term "weighting" applies to noise filters designed to pass noise frequencies in proportion to their degree of objection. Weighting filters are used for audio and video noise measurements as well. In the WTD position the flutter reading is more of an indication of just how objectionable or noticeable a speed variation will be to the ear. As an example, a flutter rate at 100 Hz of a given amplitude will not be so noticeable or objectionable as one at 10 Hz at the same amplitude. The ear is most sensitive to rates between 2 and 10 Hz.

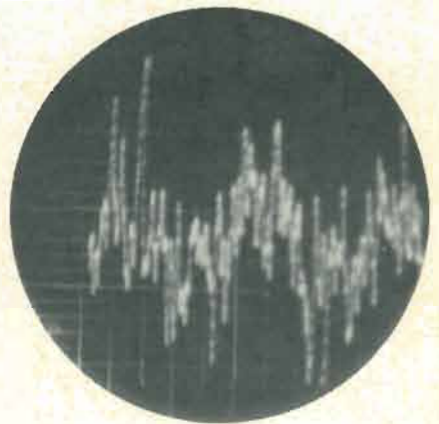

Fig. 7—Typical scope trace of flutter in tape playback. Sweep rate is 0.2 second and vertical sensitivity is 0.5 volt peak to peak. Note random characteristic of flutter in the signal.

To summarize using the flutter meter, set the mode switch to osc and record several minutes of the 5-kHz signal on a tape, at the tape speed you wish to check. Set the mode switch to STAB for at least 30 seconds or until the tape is rewound. Play the tape back into the flutter-meter input and set the mode switch to READ. Then set the range switch as required, and read the average flutter. Since flutter is usually a random thing, the meter pointer will not be steady; take an average pointer reading. Rewind the tape slightly each time and take at least four more readings. The average of the five readings will give a good indication of the tape equipment quality and condition. Well-built tape machines will average less than 0.1% flutter at 7½ ips. For checking turntables, use a frequency-test record with a 5-kHz test band on it. **R-E**



If you like  
big speakers,



## listen to the mammoth little E-V SEVEN!

Ⓔ The E-V SEVEN is the small speaker for people who don't really want a small speaker. Built in the shadow of one of the biggest speakers of them all (the vast Patrician 800) the E-V SEVEN refuses to sound as small as it is.

But why does an E-V SEVEN grow up when it's turned on? Our engineers point to years of painstaking exploration in the byways of sound. They'll patiently explain the virtues of our low resonance 8" woofer and 3½"

cone tweeter with symmetrical damping (an E-V exclusive). They may even mention—with quiet pride—the unusual treble balance RC network that adjusts E-V SEVEN response more smoothly than any conventional switch or volume control.

But when it comes to describing the sound, our engineers prefer to let the E-V SEVEN speak for itself. And while they'd be the last to suggest that the E-V SEVEN sounds just like speak-

ers many times larger (and costing much more) they treasure the pleased look of surprise most people exhibit when they hear an E-V SEVEN for the first time.

If you have just 19" of shelf space, 10" high and 9" deep...and have \$66.50 to invest in a speaker, by all means listen carefully to the E-V SEVEN. It might well be the biggest thing to happen to your compact high fidelity system!

high fidelity systems and speakers • tuners, amplifiers, receivers • public address loudspeakers • microphones • phonograph needles and cartridges • organs • space and defense electronics

ELECTRO-VOICE, INC., Dept. 1274E, 613 Cecil Street, Buchanan, Michigan 49107

**Electro-Voice**®

## EARN YOUR DEGREE Electronics Engineering Through Home Study

Highly Effective Home Study Courses In:

- Electronics Engineering Technology
- Electronics Engineering Mathematics

Earn your degree in Electronics Engineering and upgrade your status and pay to the engineering level. Complete college level courses in Electronics Engineering. Outstanding lesson material—thorough and easy to understand. Up-to-date in every respect. The knowledge and ability that means the difference between a low paying technician job and a high paying engineering position. Low tuition cost with low monthly payments. Free engineering placement service for our graduates. Write for free descriptive literature. No salesman will call on you.

### COOK'S INSTITUTE of Electronics Engineering

Established 1945

Formerly Cook's School of Electronics

**Forest Hill Road  
P. O. Box 10634  
Jackson, Mississippi 39209**

Circle 28 on reader's service card

## EQUIPMENT REPORT

*Ampex 985 Music Center*  
Circle 43 on reader's service card



WITH THE GROWING popularity of three-piece modular stereo music systems, it was only natural that Ampex should introduce a *music center*. Their device is built around a tape recorder (naturally), rather than the more common record changer/receiver concept. Housed in an attractive walnut cabinet, the music center is a three-speed ¼-track stereo and mono audio tape recorder complete with AM, FM and FM-stereo receiver. The tape transport uses bidirectional playback which eliminates reel turnover; it has a push-to-reset digital tape counter and a fingertip control panel. There are two separate electronic control panels: one for the recorder and one for the radio.

The recorder control panel has a recording mode selector (STEREO or

MONO), and a record safety button, which prevents accidental erasure of recorded programs. There are individual channel record-level meters, a five-position source and playback selector switch and dual record-level controls.

The radio control panel contains a flywheel tuning control; a mode selector for choosing FM, AM or FM-stereo reception; dual ganged bass and treble controls; individual channel loudness controls; a tuning meter effective on both FM and AM, and an FM-stereo beacon indicator.

As expected, the recorder was a joy to operate. Reel threading is as simplified as this operation can be made; after some experimenting I was able to make some creditable recordings using both microphones supplied.

An interesting innovation is the automatic reverse feature, which allows playback of both tape sides without reel turnover. This mechanism is activated by a 20-Hz signal (inaudible) recorded on the tape. The reversing signal can be dubbed onto any tapes you may presently own (pre-recorded or otherwise).

The overall frequency response of the recorder is listed by the manufacturer as 50 to 15,000 Hz  $\pm 4$  dB at the 7½-ips speed. This was actually bet-

## THE MOST USEFUL GIFTS FOR CHRISTMAS ARE GIFT WRAPPED WHEN YOU BUY 'EM

With more hi-fi kits, TV's, ham radios and electrical appliances being sold this season than ever before, it's a sure thing your friends will be needing topnotch soldering tools. Give them the best—Weller guns or Marksman irons in colorful yuletide packages. Gun kit sleeves are perforated to fit inside the open case, will be a welcomed sight under the Christmas tree . . . a useful gift all year long.



**Weller**

### SOLDERING KITS

**Dual heat soldering gun kit.** Includes trigger-controlled 100/140 watt Weller gun with 3 soldering tips, tip-changing wrench, soldering aid, flux brush and solder in plastic utility case. Holiday wrapped Model 8200PK-X.

**Heavy-duty dual heat gun kit.** Features 240/325 watt Weller gun plus extra tips for smoothing and cutting, tip-changing wrench, and solder. Holiday wrapped Model D550PK-X.

**MARKSMAN pencil iron kit by Weller.** Featherweight 25-watt iron for outstanding continuous-duty soldering, two extra tips, soldering aid and solder. Holiday wrapped Model SP23K-X.



At Your Electronic Parts Distributor . . . Available in Canada

**WELLER ELECTRIC CORP.,** Easton, Pa. World Leader in Soldering Technology

Circle 29 on reader's service card

Circle 30 on reader's service card ➔

tered by the unit I tested, using a standard-frequency test tape. Signal-to-noise ratio at 7½ ips was measured at 45 dB (as opposed to the 46 dB listed by the manufacturer). That's well within the classification of "excellent" for home recorders and better than some of the so-called "professional" recorders I've seen. More important, what little residual noise there was consisted of inobtrusive background hiss, or white noise, rather than the more annoying hum components so often prevalent in high-gain devices such as tape recorders.

While the amplifier section boasts a modest 7.5 watts per channel (15 watts combined music power), the model 830 speakers supplied with the unit I tested supplied plenty of sound—even for the concert-hall-level listener. This illustrates a seldom noted advantage of "modular component purchasing."

Since the manufacturer has control of speakers and amplifier selection, he will make sure to supply speakers which are efficient enough to operate properly with his own amplifier, regardless of its *electrical* power rating. It is, after all, *acoustic* power that counts: A 10%-efficient speaker fed by 2 watts of power will sound as loud as a 1%-efficient speaker fed by 20 watts of electrical power!

Obviously emphasizing recorder performance in the descriptive literature, Ampex failed to mention any FM or FM-stereo performance specifications, so I decided to measure them. They shouldn't have been ashamed to publish specs. IHF measured sensitivity was 5 µV, not the best there is, but certainly adequate. This was borne out by my ability to receive satisfactorily FM-stereo stations 20 miles away with full limiting action, using just the built-in dipole. Full limiting occurred with 8 µV of signal. The stereo beacon lit at 3 µV input, though reception at this level was quite noisy.

Separation for FM-stereo, with a 100-µV signal was 25 dB at 1,000 Hz on one channel, 22 dB on the other. At 10 kHz separation was still in excess of 15 dB, not bad at all for a multiplex section with only three transistors!

AM reception was quite adequate; the circuitry is conventional.

All electronics in the 985 are fully transistorized, employing a total of 42 transistors.

If tape recording is your special interest, and if the compactness of modular component approach to stereo sound has appeal, you would do well to check into the model 985 Ampex music center. —Leonard Feldman

Price: \$599.95



has  
everything  
in

# chemicals

From service cements to aerosol cleaners, from solvents to lubricants, only GC satisfies the critical chemical needs of the electronics field.

All GC chemicals are formulated to meet rigid requirements; packaged for convenience; and "proven in use" to make electronic jobs easier, faster, more profitable.

Remember too, with GC aerosols you get double value . . . highest product quality plus valuable GC "BONUS COUPONS".

Get more for your money . . . always insist on GC!

Write for your Giant FREE GC Catalog today . . . over 12,000 items including TV Hardware, Phono Drives, Chemicals, Alignment Tools, Audio, Hi-Fi, Stereo & Tape Recorder Accessories, Nuts & Bolts, Plugs & Jacks, Service Aids, and Resistive Devices.

*only GC gives you  
everything in electronics.  
..... for almost 40 years!*



Radio-Television  
Service Cement  
Cat. No. 30-2



SPRA-KLEEN  
Contact-Control Cleaner  
Cat. No. 8666



SPRA-LUBE  
Cleaner-Lubricant  
Cat. No. 8888



GC "JIF"  
Contact and Control  
Cleaner  
Cat. No. 8670



"Super Grip"  
Epoxy Glue  
Cat. No. 347



Super Freeze Mist  
Cat. No. 8888



**GC ELECTRONICS COMPANY**

400 South Wyman Street  
Rockford, Illinois 61101

A DIVISION OF HYDROMETALS, INC.

Circle 31 on reader's service card

# "King of the hill"

Keep on top of your solid-state replacements... with RCA "Top-Of-The-Line" SK-Series. They make up just a handful of types—17 transistors, 2 rectifiers, and 2 integrated circuits. Together these 21 RCA SK-Series types can keep you ahead of 9,000 solid-state replacements in entertainment-type equipment. Designed especially for this purpose, you'll find these devices useful in line-operated and battery-operated radios, phonographs, tape recorders, TV receivers, AF amplifiers, and automobile radios.

RCA SK-Series transistors and rectifiers and the 9,000 types they replace are cross-referenced in the RCA Solid-State Replacement Guide. It's a handy booklet listing comparably-rated types including industry standard EIA types, foreign types, and those identified only by device manufacturers' or equipment manufacturers' parts numbers.

Check with your RCA Distributor. He stocks the complete line in either cartons or see-through display packs. Also, pick-up your copy of the RCA Replacement Guide SPD-202-D available through your RCA Distributor.

RCA Electronic Components and Devices, Harrison, N.J. 07029



The Most Trusted Name  
in Electronics



SK-3017A



TOP-OF-THE-LINE

SILICON  
RECTIFIER

PRV 600V  
DC OUTPUT 1A MAX.  
(INSULATED TYPE)  
Replacement use  
Color, B&W TV  
Radios; Phon  
750 mA (Ca



SK-3009

TOP-OF-THE-LINE  
REPLACEMENT  
TRANSISTOR

pnp Type Audio Output  
Stages of Auto Radios



TOP-OF-THE-LINE  
REPLACEMENT  
TRANSISTOR

Silicon npn Type,  
AF Amplifier,  
Driver.



**Amphenol 870**  
**Millivolt Commander**  
*Circle 44 on reader's service card*



**Manufacturer's Specifications**

**Dc Voltmeter**  
 Ranges: 100 mV to 100 volts full scale  
 Accuracy:  $\pm 2\%$  of full scale  
 Input resistance: 10.6 megohms

**Ac Voltmeter**  
 Ranges: 10 mV to 300 volts rms full scale  
 Accuracy:  $\pm 3\%$  of full scale  
 Input impedance: 10 megohms, 50 pF

**Decibels**  
 Ranges: -40 to +50 dBm  
 Accuracy:  $\pm 3\%$  full scale, 50 Hz-50 kHz

**Ohmmeter**  
 Ranges: 10 ohms to 10 megohms center scale  
 Accuracy:  $\pm 3\%$  of arc

Size:  $9\frac{1}{4}'' \times 5\frac{3}{4}'' \times 6\frac{3}{8}''$   
 Weight: 5 lb  
 Price: \$99.95

FOR MANY YEARS, most of us have struggled with non-portable vtm's which had to be plugged into an ac line and warmed up every time we moved 'em. If you needed high input impedance to avoid circuit loading, you babied that vtm, 'cause a vom wouldn't do the job.

Amphenol's Millivolt Commander, model 870, will do the job. Input impedance is 10 megohms on all ranges, and the instrument has full-scale deflection of 100 mV on dc and 10 mV on ac. These features are obtained by using an FET input stage. The entire voltmeter is solid-state and battery-operated, for complete portability and stability.

There's still another advantage—you aren't tied to the ac line, so you can hang the meter across nearly any kind of circuit with no regard for where the ground is.

You'll find the model 870 can measure almost any voltage or resistance you run into in electronic servicing—with the possible exception of TV high voltage. Accuracy is good (see below) and the instrument is stable. In the dc mode, there is 60 dB of ac rejection at the 60-Hz line frequency.

The heart of this voltmeter is a dc amplifier which has good temperature stability. To eliminate drift, this amplifier is supplied with a constant bias voltage; the cells supplying this voltage are loaded with a constant current. Drain is minimal, and the cells should last two years in normal service.

Actually, there are three separate battery supplies: One is used for the ohms supply, one for the zero reference, and one for the amplifier supply. All batteries are AA size. Zinc-carbon cells are cheapest, but for best and longest performance, you might want to try alkaline cells.

One thing I noticed was the appreciable effect of the ohms battery on the accuracy of the Rx1 scale. I put a 15-ohm, 1% resistor across the test leads on the Rx1 scale of the 870 as supplied by Amphenol. The reading was 9 ohms. Then I replaced the ohms battery with a fresh cell and read 13 ohms (which is within specifications).

Good mechanical design is evident in the model 870. The meter movement has been designed to operate satisfactorily in both the horizontal and the vertical plane, so you can set up the voltmeter any way you want. A brace in back permits you to tilt the meter up at a 45° angle when reading it.

The circuit is shielded by a metal interior case (to avoid stray pickup) with a leatherette exterior case and front-panel cover (for portability).

You can do a lot with the Millivolt Commander. You can check microphones and phono cartridges for output level and balance, you can measure transistor bias voltages, and you can evaluate the performance of small-signal equipment. All in all, this is a most handy instrument.

—Ray Clifton

**R-E**

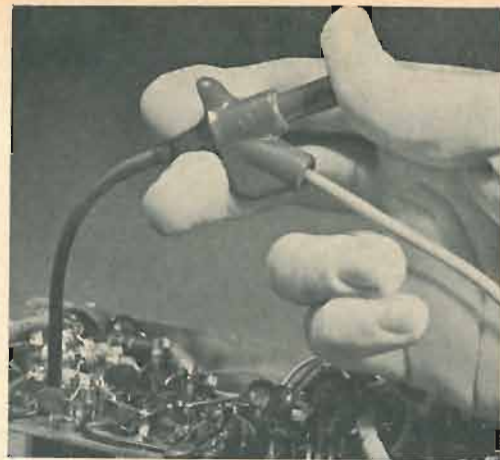

## Clever Kleps 30

Push the plunger. A spring-steel forked tongue spreads out. Like this  Hang it onto a wire or terminal, let go the plunger, and Kleps 30 holds tight. Bend it, pull it, let it carry dc, sine waves, pulses to 5,000 volts peak. Not a chance of a short. The other end takes a banana plug or a bare wire test lead. Slip on a bit of shield braid to make a shielded probe. What more could you want in a test probe?



Available through your local distributor, or write to:

**RYE INDUSTRIES INC.**  
 128 Spencer Place, Mamaroneck, N.Y. 10543  
*Circle 33 on reader's service card*

**\$147**

## GAS WELDING TORCH



*Uses OXYGEN and LP GAS*

- Completely self-contained.
- Produces 5000° pin-point flame.
- Welds, brazes, solders.
- Hundreds of lightweight uses.
- Suggested list — \$19.95.

GET COMPLETE DETAILS AT MOST INDUSTRIAL DISTRIBUTORS, OR WRITE TO MICROFLAME, INC.



**MICROFLAME, INC.**

7800 COMPUTER AVENUE  
 MINNEAPOLIS, MINNESOTA 55424

*Circle 34 on reader's service card*

# 14 KIT-GIVING IDEAS FROM HEATH...

For The Whole Family...

## New Deluxe "227" Color TV

Exclusive Heathkit Self-Servicing Features. Like the famous Heathkit "295" and "180" color TV's, the new Heathkit "227" features a built-in dot generator plus full color photos and simple instructions so you can set-up, converge and maintain the best color pictures at all times. Add to this the detailed trouble-shooting charts in the manual, and you put an end to costly TV service calls for periodic picture convergence and minor repairs. No other brand of color TV has this money-saving self-servicing feature.

Advanced Features. Boasts new RCA Perma-Chrome picture tube for 38% brighter pictures... 227 sq. in. rectangular viewing area... 24,000 v. regulated picture power... improved phosphors for brilliant, livelier colors... new improved low voltage power supply with boosted B+ for best operation... automatic degaussing... exclusive Heath Magna-Shield to protect against stray magnetic fields and maintain color purity... ACC and AGC to reduce color fade and insure steady, flutter-free pictures under all conditions... preassembled & aligned IF with 3 stages instead of the usual 2... preassembled & aligned 2-speed transistor UHF tuner... deluxe VHF turret tuner with "memory" fine tuning... 300 & 75 ohm VHF antenna inputs... two hi-fi sound outputs... 4" x 6" 8 ohm speaker... choice of installation — wall, custom or optional Heath factory assembled cabinets. Build in 25 hours.

**Kit GR-227**, (everything except cabinet)... \$42 dn., as low as \$25 mo. ... 114 lbs. .... **\$419.95**  
**GRA-227-1**, Walnut cabinet... no money dn., \$6 mo. .... **\$59.95**  
**GRA-227-2**, Mediterranean Oak cabinet (shown above) ... no money dn., \$10 mo. .... **\$94.50**



Kit GR-227  
**\$419.95** (less cabinet)  
 \$25 mo.



Kit GRA-27  
**\$19.95**

## New Remote Control For Heathkit Color TV

Now change channels and turn your Heathkit color TV off and on from the comfort of your armchair with this new remote control kit. Use with Heathkit GR-227, GR-295 and GR-180 color TV's. Includes 20' cable.



Kit GR-295  
**\$479.95**  
 (less cabinet)  
 \$42 mo.

## Deluxe Heathkit "295" Color TV

Color TV's largest picture... 295 sq. in. viewing area. Same features and built-in servicing facilities as new GR-227. Universal main control panel for versatile in-wall installation. 6" x 9" speaker.

**Kit GR-295**, (everything except cabinet), 131 lbs. ... \$48 dn., \$42 mo. .... **\$479.95**  
**GRA-295-1**, Walnut cabinet (shown above), 35 lbs. ... no money dn., \$7 mo. .... **\$62.95**  
 Other cabinets from \$94.50



Kit GR-180  
**\$349.95**  
 (less cabinet & cart)  
 \$30 mo.

## Deluxe Heathkit "180" Color TV

Same high performance features and exclusive self-servicing facilities as new GR-227 (above) except for 180 sq. in. viewing area.

**Kit GR-180**, (everything except cabinet), 102 lbs. ... \$35 dn., \$30 mo. .... **\$349.95**  
**GRS-180-5**, table model cabinet & mobile cart (shown above), 57 lbs. ... no money dn., \$5 mo. .... **\$39.95**  
 Other cabinets from \$24.95



**FREE...** 40-Lesson Record Course With Either Heathkit / Thomas Organ! A \$50 Value! Includes four 33 1/3 rpm records, music book & leatherette album.

Kit TO-67  
**\$995**  
 (including bench)  
 \$200 dn.,  
 as low as \$29 mo.

## Heathkit®/Thomas "Paramount" Theatre Organ

Save Up To \$500! Build in 80-100 hours. All Thomas factory-made parts... 15 manual, 4 pedal voices; instant-play Color-Glo; all-transistor circuit; 200 watts peak power; 2-speed rotating Leslie plus main speaker system with two 12" speakers; 44-note keyboards; horseshoe console with stop tablets; 28-note chimes; 13-note bass pedals; repeat & attack percussion; reverb; headset outlet; assembled walnut finish hardwood cabinet & bench; and more. 265 lbs. 7", 33 1/3 rpm demonstration record 50c.

## America's Lowest Cost Solid-State Organ

Kit GD-325B  
**\$394.90**  
 \$40 dn., \$34 mo.

Save Up To \$205! Instant-play Color-Glo; 10 voices; 13-note bass pedals; repeat percussion; 37-note keyboards; 75-watt peak power; vibrato; assembled walnut cabinet & bench. 172 lbs. 7", 33 1/3 rpm demonstration record 50c.



## Exclusive Band Box Percussion

Automatically or manually adds 10 percussion voices to any Heathkit/Thomas organ. Build & install in 12 hours.

**Kit TOA-67-1**, no money dn., \$14 mo. .... **\$145.00**

## Exclusive Playmate Rhythm Maker

Adds 15 fascinating rhythms to any Heathkit/Thomas Organ. Requires Band Box percussion (above) for operation.

**Kit TOA-67-5**, no money dn., \$18 mo. .... **\$189.90**



# USE COUPON BELOW TO ORDER NOW

## NEW! VOX "Jaguar" Transistor Combo Organ By Heathkit



Kit TO-68  
**\$349.95**  
\$35 dn., \$30 mo.

Save Up To \$150 on the world's most popular combo organ with this new Heathkit version. Features the most distinctive sound of any combo organ. Has a special bass output that gives a brilliant stereo bass effect when played through a separate or multi-channel amplifier, 4 complete octaves, vibrato, percussive effects and reversible bass keys. Includes hand crafted orange and black cabinet, fully plated heavy-duty stand, expression pedal and waterproof carrying cover and case for stand. Requires a bass or combo amplifier like Heathkit TA-17 (opposite page).

**Kit TO-68**, 80 lbs. . . \$35 dn., \$30 mo. . . . . **\$349.95**

## NEW! Deluxe Solid-State Combo Amplifier & Speaker System . . . Choose Kit Or Factory Assembled

Amplifier  
Kit TA-17  
**\$175**  
\$17 mo.  
(Assembled  
TAW-17 \$275)

Speaker System  
Kit TA-17-1  
**\$120**  
\$11 mo.  
(Assembled  
TAW-17-1 \$150)

**Special  
Combination Offer**  
Amplifier & Two  
Speaker Systems  
Save \$20  
Kit TAS-17-2  
**\$395**  
\$40 dn.  
\$34 mo.  
(Assembled  
TAW-17-2 \$545)



All the "big sound" features every combo wants . . . tremolo, built-in "fuzz", brightness, reverb, separate bass and treble boost and more. Delivers a shattering 120 watts EIA music power (240 watts peak power) through two TA-17-1 speakers . . . or 90 watts through one TA-17-1 speaker. Features 3 independent input channels, each with two inputs. Handles lead or bass guitars, combo organ, accordion, singer's mike, or even a record changer. All front panel controls keep you in full command of all the action.

Speaker system features two 12" woofers, special horn driver and matching black vinyl-covered wood cabinet with casters & handles for easy mobility.

## NEW! Lowest Cost Solid-State Stereo Receiver

Kit AR-17  
**\$72.95**  
(less cabinet)  
\$8 mo.



Features wide 18-60,000 Hz response @ ±1 db at full 5 watts RMS power per channel . . . 14 watts music power . . . inputs for phono and auxiliary . . . automatic stereo indicator . . . outputs for 4 thru 16 ohm speakers . . . adjustable phase for best stereo . . . flywheel tuning . . . and compact 9 3/4" D. x 2 7/8" H. x 11 3/4" W. size. 12 lbs. Optional factory assembled cabinets (walnut \$7.95, beige metal \$3.50).

**Kit AR-17**, (less cab.) 12 lbs. . . no money dn., \$8 mo. . . **\$72.95**  
**Kit AR-27**, 7-Watt FM Mono Only Receiver (less cab.)  
9 lbs. . . no money dn., \$5 mo. . . . . **\$49.95**



Kit AR-15  
**\$329.95**  
(less cabinet)  
\$28 mo.

Assembled  
ARW-15 \$499.50  
(less cabinet) \$43 mo.

## World's Most Advanced Stereo Receiver

Acclaimed by owners & experts for features like integrated circuits & crystal filters in IF amplifier; FET FM tuner; 150 watts music power; AM/FM and FM stereo; positive circuit protection; all-silicon transistors; "black magic" panel lighting; and more. Wrap-around walnut cabinet \$19.95

**Kit AR-15** (less cab.), 34 lbs. . . \$33 dn., \$28 mo. . . . **\$329.95**  
**Assembled ARW-15**, (less cab.), 34 lbs. . . \$50 dn.,  
\$43 mo. . . . . **\$499.50**

## Professional 10-Band Shortwave Receiver

Kit SB-310  
**\$249**  
\$23 mo.



Covers 49, 41, 31, 25, 19 & 16 meter shortwave . . . 80, 40 & 20 meter ham . . . 11 mete · CB Includes 5 kHz crystal filter for AM, SSB and CW listening. Features selectivity that slices stations down to last kHz; 11-tube circuit; crystal-controlled front-end and more. 20 lbs. SB-600 8 ohm 6" x 9" speaker in matching cabinet \$18.95.

## NEW! Solid-State Portable Volt-Ohm-Meter

Kit IM-17  
**\$19.95**



So Handy, So Low Cost we call it "every man's" meter. Just right for homeowners, hobbyists, boatowners, CBer's, hams . . . it's even sophisticated enough for radio & TV servicing! Features 12 ranges . . . 4 AC & 4 DC volt ranges, 4 ohm ranges; 11 megohm input on DC, 1 megohm input on AC; 4 1/2" 200 uA meter; battery power; rugged polypropylene case and more. Easy 3 or 4 hour kit assembly. Ideal gift for any man! 4 lbs.



## NEW FREE 1968 CATALOG!

Now with more kits, more color Fully describes these along with over 300 kits for stereo hi-fi, color TV, electronic organs, electric guitar & amplifier, amateur radio, marine, educational, CB, home & hobby. Mail coupon or write Heath Company, Benton Harbor, Michigan 49022.

HEATH COMPANY, Dept. 20-12  
Benton Harbor, Michigan 49022  
In Canada, Daystrom Ltd.

Enclosed is \$ \_\_\_\_\_, including shipping.

Please send model (s) \_\_\_\_\_

Please send FREE Heathkit Catalog.

Please send Credit Application.

Name \_\_\_\_\_

Address \_\_\_\_\_

City \_\_\_\_\_

State \_\_\_\_\_

Zip \_\_\_\_\_

Prices & specifications subject to change without notice.

CL-310

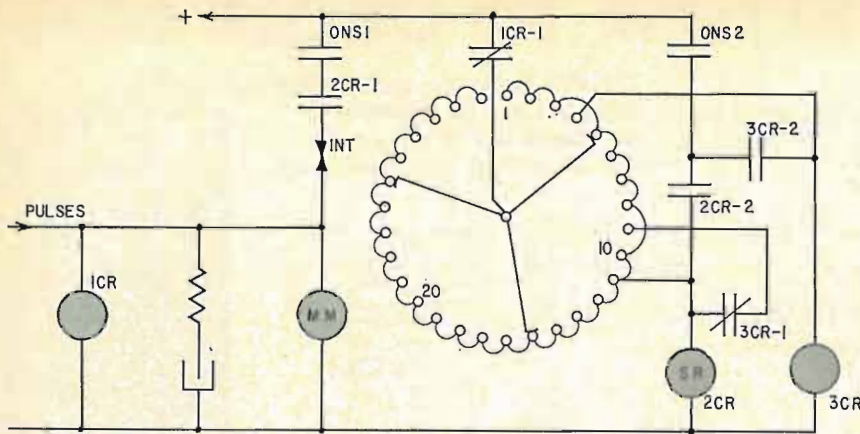

Fig. 6—A 3-digit selector using type 44 switch. Can be reset with a single pulse.

## Rotary Stepping Switches

(continued from page 48)

switch stay in the last position it reaches.

For example, with the circuit shown, we can dial circuit 9 only by dialing first 4 and then 5. Any other sequence causes the stepping switch to home. 1CR-1 opens at the beginning of the first series of pulses, disconnecting the battery from the wiper and prevents false triggering. At the end of the pulse 1CR-1 closes and connects the battery to the wiper. If the correct number (4) had been dialed, 3CR is energized and locked in through 3CR-2 and ONS2. The next series of 5 pulses steps the switch to position 9.

If the code is misdialled or 9 is dialed directly, 2CR is energized and the stepping switch homes through 2CR-1 and off-normal contacts ONS1.

For low digits an additional relay may be needed, to prevent landing on the third digit position. It would be necessary to use a second code of pulses to ensure that the switch comes to rest successively on all three points or not at all. Line connection is made through a second level of contacts (not shown in the diagram). Any additional pulse after the three-digit code will of course have the same effect as too many pulses—it will send the switch home.

Where only a few selectors are to be used on a line, relay RY1 can be eliminated simply by making the first digit 0 (tenth contact) and the second digit 9 or 0. This makes it unlikely that accidental connection could take place, yet allows for the use of 9 selectors. With that many pulses needed it is also unlikely that accidental connection could take place, yet the circuit allows for the use of 9 selectors. It is equally unlikely that random pulse noise might connect a selector.

The circuit of Fig. 6 has many applications. It can be used to read voltages or currents of a remotely located transmitter (or any other electronic device, for that matter). A suitable meter would be used at the dial (pulse-originating) location, while series and shunt connections would be made at the stepper (pulse-receiving) location.

Another use would be to switch microphone circuits remotely into a single amplifier and line.

Rotary stepping switches have been used for many years in telephone, communications and industrial electronics. Today's models are highly sophisticated and capable of complex functions. In spite of the hundreds of thousands of steppers in daily use, many persons interested in electronics have little knowledge of stepping-switch function. These switches aren't really so complicated, however, as this series has shown. **R-E**

# NO MORE GUESSWORK!



AMERICA'S MOST RELIABLE TUBE ANALYZER



# CONTINENTAL

You don't need three guesses to tell if a tube is bad—or why. With the new Sencore MU140 Continental, you **know**. Right now. And you simply can't go wrong. Because it's a complete tube analyzer for 4-way testing—true mutual conductance (using exclusive 5000 hertz square wave), full cathode emission, 100 megohm grid leakage, and internal shorts. Tests all tubes, including foreign—over 3000 in all. Obsolete-proof, too—with "new socket" panel, and controls so standard the switch numbers correspond to the pin numbers in any tube manual.

If it's reliability you want—for years to come—you need the Continental. It's the best way to be sure—

See America's most complete line of professional test instruments—at your Distributor now.

for only  
**\$179.50**



## SENCORE

NO. 1 MANUFACTURER OF ELECTRONIC MAINTENANCE EQUIPMENT  
426 SOUTH WESTGATE DRIVE, ADDISON, ILLINOIS 60101

Circle 37 on reader's service card



## The FCC License

(continued from page 2)

of stations: experimental, auxiliary, booster, translator, and instructional fixed TV; developmental and remote-pickup broadcast; noncommercial educational FM broadcast with power output not more than 1 kW; CATV relay; land, maritime, aviation, public safety, industrial, land transportation, and domestic public. You may perform maintenance at a ship radar station only with a ship radar endorsement.

If you get a *Radiotelephone First-Class license* you have the most privileges (and the most qualifications) in this group. You may operate all the preceding, plus AM broadcast stations with power output over 10 kW or with directional antennas, FM stations with power output over 25 kW, TV stations and shortwave broadcast stations.

You may also perform servicing and maintenance at those stations so listed under *Radiotelephone Second-Class*, plus AM broadcast, commercial FM, TV, shortwave broadcast, and noncommercial educational FM stations with power output over 1 kW. You may perform maintenance at a ship radar station only with a ship radar endorsement.

The *Radiotelegraph Third-Class permit* holder is quite limited in permissible duties, and may operate only land maritime telegraph and telephone stations, ship maritime telephone, public-safety telegraph and telephone, industrial telephone and telegraph, land transportation telephone and telegraph, domestic public telegraph, and international fixed public stations. He may not perform any servicing or maintenance.

A *Radiotelegraph Second-Class license* allows you to operate all the preceding, plus AM broadcast stations with both power output of 10 kW or less and nondirectional antennas, FM stations with power output of 25 kW or less, and remote-pickup broadcast stations. You may also operate aircraft telegraph stations but *only* if you are at least 18 years of age and have an aircraft telegraph endorsement, and have passed a code test of 25 wpm.

This license, like its radiotelephone counterpart, is for the technician. With it, you may perform maintenance at noncommercial educational FM stations with not more than 10 watts power, land and ship maritime telegraph, aircraft telegraph, public-safety telegraph and telephone, industrial telegraph and telephone, land transportation telegraph and telephone, and domestic public telegraph stations. You may perform maintenance at a ship radar station only with a ship radar endorsement.

The *Radiotelegraph First-Class license* is the most difficult ticket to get, and it really means something. To insure the safety of life at sea, the holder of this license may not only operate all the preceding, but *only he* may act as chief or sole operator on a cargo vessel (other than a vessel operated exclusively on the Great Lakes) which is required by treaty or statute to be equipped with a radiotelegraph installation, and only after he has completed 6 months' service as a radio operator aboard a US ship.

With this license, you may perform maintenance at those stations listed under *Radiotelegraph Second-Class*. You may also operate aircraft telegraph stations, but only with an aircraft telegraph endorsement. You may perform maintenance duties at a ship radar station only with a ship radar endorsement.

An FCC operator license can mean a lot in your electronics future. Make it easy on yourself—try for a Third, or maybe a Second. Study one element at a time. With a second phone you can do CB, two-way business radio and trucking company servicing. Then get that first phone. Or, if you'd like to go to sea, study code and try for a second telegraph. But get that ticket. You may find it's your meal ticket—and you may find yourself eating steak. **R-E**

# JERROLD

## Focusing on one thing... better reception

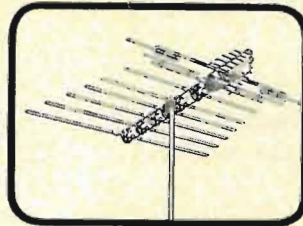

Outdoor antennas

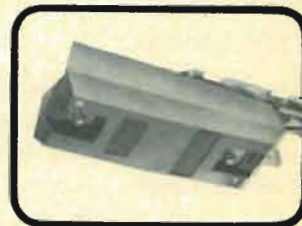

Home preamplifiers

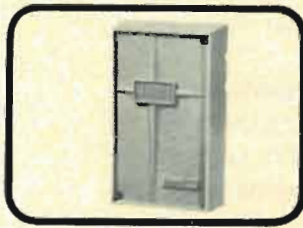

Distribution equipment

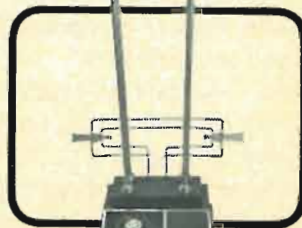

Indoor antennas

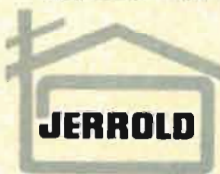

**Jerrold Electronics Corporation**

Distributor Sales Division  
401 Walnut St., Philadelphia, Pa. 19105

Circle 38 on reader's service card

## The Second Generation Arrives!

# TRAM<sup>®</sup> TITAN II

Standard AM and Double Sideband

Suppressed Carrier Citizens Band Base Station

Now—Tram wraps two CB rigs into one. The mighty Tram Titan II in sideband operation, focuses more talk-power than ever with much greater range, virtual immunity from pulse-type and skip interference, plus a choice of either upper or lower sideband reception or standard AM tuning. Completely compatible with AM, DSBRC, DSBSC and SSB.

Titan II, at authorized Tram dealers, \$482

SEND FOR BROCHURE No. G-12

**TRAM CORPORATION**

Lower Bay Road, Winnisquam, N. H. 03289  
Phone 603-524-0622

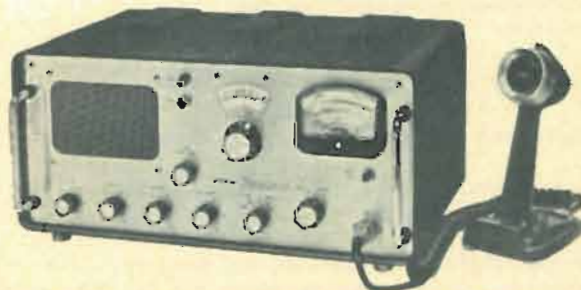

All use must conform with Part 95, F.C.C. regulations. Hobby type communications or aimless small talk prohibited.

Circle 39 on reader's service card

## RADIO-ELECTRONICS READER'S SERVICE

Here's how you can get manufacturers' literature fast:

1. Tear out the post card on the facing page. Clearly print or type your name and address.

**Include zip code! Manufacturers will not guarantee to fill your requests unless your zip code is on the reader service card!**

2. Circle the number on the card that corresponds to the number appearing at the bottom of the **New Products, New Literature or Equipment Report** in which you are interested.

For literature on products advertised in this issue, circle the number on the card that corresponds to the number appearing at the bottom of the advertisement in which you are interested. Use the convenient index below to locate quickly a particular advertisement.

3. Mail the card to us (no postage required in U.S.A.)

**Advertisements in this issue offering free literature (see the advertisements for products being advertised):**

ALLIED RADIO CORP. (Pg. 76)	Circle 107
ARCTURUS ELECTRONICS CORP. (Pg. 94)	Circle 141
ARTISAN ORGANS (Pg. 80)	Circle 113
BROOKS RADIO & TV CORP. (Pg. 88-89)	Circle 117
BURSTEIN-APPLEBEE CO. (Pg. 86)	Circle 126
CASTLE TV TUNER SERVICE, INC. (Pg. 91)	Circle 121
CLEVELAND INSTITUTE OF ELECTRONICS (Pg. 5)	Circle 12
CLEVELAND INSTITUTE OF ELECTRONICS (Pg. 63-64)	Circle 30
COOK'S INSTITUTE OF ELECTRONICS ENGINEERING (Pg. 62)	Circle 28
CORNELL ELECTRONICS CO. (Pg. 96)	Circle 145
DELTA PRODUCTS, INC. (Pg. 60)	Circle 26
EDMUND SCIENTIFIC CO. (Pg. 95)	Circle 142
EICO ELECTRONIC INSTRUMENT CO., INC. (Third Cover)	Circle 149
FINNEY CO. (Pg. 15)	Circle 19
GC ELECTRONICS COMPANY (Pg. 65)	Circle 31
HEALD COLLEGES. (Pg. 91)	Circle 122
HEATH COMPANY (Pg. 68-69)	Circle 36
INJECTORALL ELECTRONICS CORP. (Pg. 22)	Circle 22
INTERNATIONAL CRYSTAL MFG. CO., INC. (Pg. 98)	Circle 148

JERROLD ELECTRONICS CORPORATION (Distributor Sales Division) (Pg. 71)	Circle 38
JFD ELECTRONICS CO. (Pg. 2)	Circle 9
MALLORY DISTRIBUTOR PRODUCTS COMPANY (Div. of P. R. Mallory & Co., Inc.) (Pg. 17)	Circle 21
MICROFLAME, INC. (Pg. 67)	Circle 34
MIKE QUINN ELECTRONICS (Pg. 97)	Circle 146
MULTICORE SALES CORP. (Pg. 91)	Circle 120
MUSIC ASSOCIATED (Pg. 79)	Circle 111
NOVA-TECH, INC. (Pg. 79)	Circle 110
OLSON ELECTRONICS, INC. (Pg. 92)	Circle 123
OXFORD TRANSDUCER COMPANY (A Division of Oxford Electric Corporation) (Pg. 80)	Circle 112
PHILADELPHIA WIRELESS TECHNICAL INSTITUTE (Pg. 93)	Circle 125
POLY PAKS (Pg. 97)	Circle 147
QUAM-NICHOLS COMPANY (Pg. 6)	Circle 13
RCA ELECTRONIC COMPONENTS AND DEVICES SEMICONDUCTORS (Pg. 66)	Circle 32
READING IMPROVEMENT PROGRAM (Pg. 89)	Circle 118
RYE INDUSTRIES, INC. (Pg. 67)	Circle 33
SALCH & CO., INC., HERBERT (Marketing Division of Tompkins Radio Products) (Pg. 80)	Circle 114
SAMS & CO., INC., HOWARD W. (Pg. 14)	Circle 18
SCHOBBER ORGAN CORP., INC. (Pg. 4)	Circle 11
SCOTT, INC., H. H. (Pg. 22)	Circle 100
SEMITRONICS CORP. (Pg. 76)	Circle 108
SENCORE (Pg. 70)	Circle 37
SENCORE (Pg. 87)	Circle 115
SENTRY MANUFACTURING COMPANY (Pg. 27)	Circle 25
SHURE BROS. (Pg. 75, 77, 79)	Circle 106
SOLID STATE SALES (Pg. 95)	Circle 143
SONOTONE CORP. (Electronic Applications Div.) (Pg. 88)	Circle 116
SONY CORP. OF AMERICA (Pg. 4)	Circle 10
SONY/SUPERSCOPE (Pg. 16)	Circle 20
SPRAGUE PRODUCTS COMPANY (Pg. 78)	Circle 109
SURPLUS CENTER (Pg. 92)	Circle 124
SYLVANIA (Subsidiary of General Telephone & Electronics) (Pg. 23)	Circle 23
TAB BOOKS (Pg. 90)	Circle 119
TRAM CORPORATION (Pg. 71)	Circle 39
TRIPLETT ELECTRICAL INSTRUMENT COMPANY (Second Cover)	Circle 7
WARREN ELECTRONICS COMPONENTS (Pg. 96)	Circle 144
WELLER ELECTRIC CORP. (Pg. 62)	Circle 29
WINEGARD CO. (Pg. 24-25)	Circle 24
XCELITE, INC. (Pg. 14)	Circle 17

# NEW AUDIO EQUIPMENT

More new product information is available free from the manufacturers of items identified by a Reader's Service number. Turn to the Reader's Service Card facing page 72 and circle the numbers of the new products on which you would like information. Detach and mail the postage-paid card.

**65-WATT STEREO RECEIVERS,** FM stereo 342B, and AM/FM stereo 382B. Both feature Scott FET circuitry, which eliminates all cross modulation and drift in both AM and FM. Driver and output transformers are eliminated from the design of the two models. Output is direct coupled, each model has dual speaker switches for main, remote, both speakers, or all-speakers-off for headphone listen-



ing; noise filter; front panel headphone jack; separate bass, treble, and volume controls for each channel. Both receivers achieve 2.2  $\mu$ V sensitivity with 80 dB cross-modulation rejection. Separation is 36 dB. 382B features automatic variable bandwidth and automatic gain control. 342B features integrated circuit i.f. 342B is \$299.95 and 382B is \$339.95.—H. H. Scott, Inc.

Circle 46 on reader's service card

**FOUR SPEAKER SYSTEMS.** The *Maximus 22* is a 2-way system (shown) and *Maximus 55* is a 3-way system. Both may be used horizontally on bookshelves or in a vertical position, free standing. The *Maximus 33* and *Maximus 44*, along with the other models, offer an integrated line of speakers. All units employ the acoustic suspension principle with a

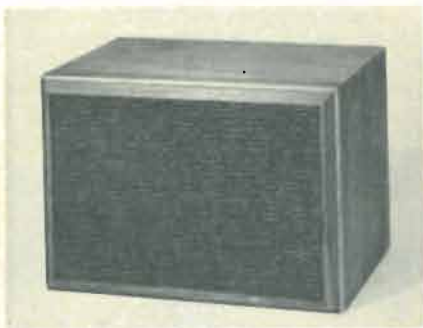

higher efficiency because of the magnetic design, permitting use of amplifiers of relatively low power. They all have removable grilles to permit use of custom grille fabrics to blend with room decor, and make cleaning easy. All speakers have hand-rubbed, oiled walnut cabinets. *Maximus* series 22, 55, 33, and 44 are \$39.95, \$99.50, \$56.00, and \$76.00 respectively.—UTC Sound, Div. of TRW.

Circle 47 on reader's service card

**CASSETTE CARTRIDGE TAPE RECORDER,** The M8320 is operated on four "C" batteries. Play, record, rewind and stop functions are controlled by a slide switch. This unit features a remote control microphone with pouch, a detachable carry strap, a neon recording-level



indicator, capstan drive for constant tape speed and a cassette guard which prevents accidental tape erasure. Optional accessories are an ac converter, a patch cord and an earphone. 60 or 120 minute blank or pre-recorded music cassettes may be used. \$49.95—General Electric

Circle 48 on reader's service card

**3-SPEED TAPE RECORDER,** Model 1040. Detachable speakers are this unit's feature. It uses 4-track stereo and mono at 7½, 3¾ and 1½ ips. Instant stopping permits editing as you go. The same single control is used for rewind, stop, play and fast forward operations. Novice and expert operators will find the digital counter and the two VU meters useful.

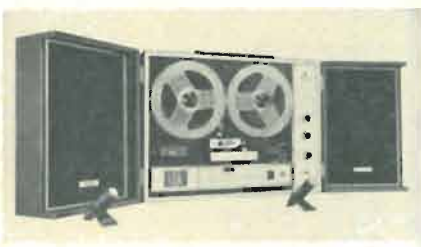

The solid-state amplifier (10-watt peak) has a fold-down panel which conceals recording controls, record interlock and inputs. The recorder and speaker fold into a compact portable case. Shutoff is automatic. Response: 30–18,000 Hz at 7½ ips; flutter and wow: less than 0.15% at 7½ ips. \$169.95 price includes two speakers, 2 microphones, 7" take-up reel and patch cords.—Allied Radio Corp.

Circle 49 on reader's service card

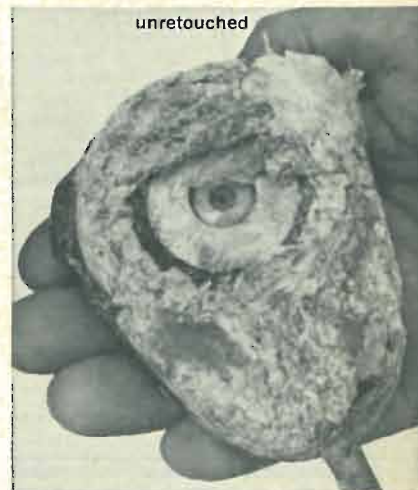
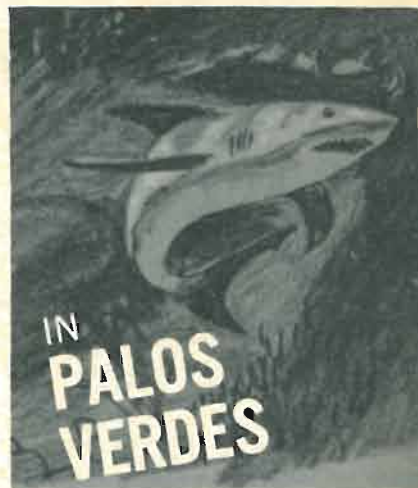

**SHURE  
MICROPHONE  
ATTACKED  
BY  
OCEAN  
TERROR**

This Shure hand-held microphone was suspended over Marineland of the Pacific to pick up the "voice" of a porpoise. An undiscovered pinhole break in an external protective plastic cover subjected the unit to ruinous salt spray for months on end. But since Shure routinely tests microphones with salt spray, it wasn't particularly surprising that after being corroded beyond recognition

**... IT STILL  
WORKED**

© 1967 Shure Brothers, Inc.

Circle 106 on reader's service card

# FREE!

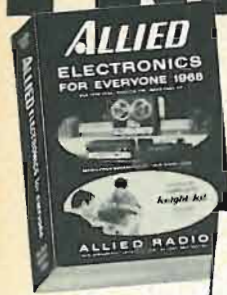

**ALLIED**  
NEW 1968  
CATALOG  
518  
PAGES

**SAVE ON:**

- Famous Knight-Kits®
- Stereo Hi-Fi
- Tape Recorders, Tape
- CB 2-Way Radios
- Walkie-Talkies
- FM-AM & AM Radios
- Shortwave Receivers
- Portable TV
- Phonographs
- Amateur Gear
- Intercoms & PA
- Automotive Electronics
- Test Instruments
- TV Antennas & Tubes
- Power Tools, Hardware
- Tubes, Transistors
- Parts, Batteries, Books

**TOP SAVINGS ON THE BEST IN ELECTRONICS FOR EVERYONE**

Shop by mail and save at Allied, world's largest electronics headquarters. Hundreds of money-saving values. NO MONEY DOWN. Up to 2 years to pay!

**MAIL COUPON BELOW**

ALLIED RADIO, Dept. 2M  
P.O. Box 4398, Chicago, Ill. 60680

NAME (Please Print) \_\_\_\_\_

ADDRESS \_\_\_\_\_

CITY \_\_\_\_\_

STATE \_\_\_\_\_

ZIP \_\_\_\_\_

Circle 107 on reader's service card

## EASY TO BUILD SOLID STATE ELECTRONIC KITS

FOR STUDENTS, BEGINNERS AND HOBBYISTS

With these Semitronic Kits, you learn by doing. Build complete, functional electronic equipment. Here are a few of the projects you can construct quickly. Each project works—all have been laboratory tested. No technical background needed, no special tools required—just pliers, screwdriver, & soldering iron.

**KITS NOW AVAILABLE:**

- 2-Transistor Radio, a hot little AM radio, w/plastic case and earphone . . . Model SS-1200, \$4.95
- Code Instructor, 2-transistor oscillator for practicing Morse code, for Ham license, etc. . . . Model CI-10, \$1.95 (w/spkr, \$2.95)
- Electronic Organ, 8 keys, plays tunes . . . Model EO-15, \$3.95 (w/spkr, \$4.95)
- Electronic Siren, for burglar alarms, fire, bike, auto, or model trains, etc. . . . Model ES-12, \$3.95 (w/spkr, \$4.95)
- Intercom, sensitive, uses 1 or more speakers, for room-to-room conversations . . . Model IC-20, \$3.95 (less spkrs)
- Universal Amplifier, a 3-transistor unit for dozens of uses in the lab, for mike and telephone . . . Model UA-3, \$3.95
- Electronic Project Book, by Semitron. With this book any student, beginner, hobbyist, can have fun and excitement of building electronic projects that work—even if you've never worked with electronics before. Projects use inexpensive parts . . . EP-1, \$2

**ALSO AVAILABLE:**

- Chass-Eze, electronic construction kit, great for bread-boarding experimental circuits quickly . . . Model PB-46, only \$1.89

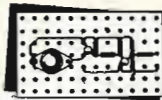

When ordering by mail, please include Model No.

### SEMITRONICS CORP.

265 Canal St., New York, N.Y. 10013  
School Discounts Available

Circle 108 on reader's service card

## New Audio Equipment

continued from page 75

**SOLID-STATE P.A. AMPLIFIERS, Challenger CHS series.** Available in four models ranging in power from 20 watts to 100 watts, this new line will operate at full output from  $-20^{\circ}\text{C}$  ( $-4^{\circ}\text{F}$ ) to  $+65^{\circ}\text{C}$  ( $+149^{\circ}\text{F}$ ). In higher powered models, CHS100 and CHS50, all-silicon semiconductors are used. Rated at 100 watts and 50 watts, respectively, these amplifiers have two microphone inputs. The 35-watt CHS35 offers two mike inputs and can be operated from a 12-volt battery as well as ac. Model CHS20 is rated at 20 watts and has one mike input.



All models have two auxiliary inputs on a fader control. The CHS chassis has a panel-mounted preamp designed for two additional microphones. The accessory, PMA-2, can be inserted in less than five minutes. All models have both high- and low-impedance microphone inputs. A built-in circuit permits microphone precedence over music or adjustment of volume from distances up to 2,000 feet. Memory Markers aid in returning controls to previously determined levels without blare or dead spots. Other features include wide-frequency response, individual amplifier control, constant-voltage output, light-weight cabinet. Accessories such as phonograph tops, locking cover, rack panel mounting kit, remote controllers, carrying case are available. Bogen CHS100 shown.—Bogen Communications Div./Lear Siegler, Inc.

Circle 50 on reader's service card

**STEREO HEADPHONES.** Norelco has introduced its new Models K-20 and K-60 stereo headphones. Both weigh eleven ounces. The standard K-20 has a single tension-spring head band and plastic ear cushions. Frequency range is 20 to 20,000 Hz; impedance is 600 ohms per



channel. The K-60 deluxe professional headset has a multi-adjustable dual head band and cushioned ear-fitting cups. Its frequency range and impedance level are the same as in model K-20. K-20 is \$19.50 and K-60 is \$39.50.—North American Philips Co., Inc.

Circle 51 on reader's service card

# NO COMPETITORS

Nobody else but **EMC** designs in so much value

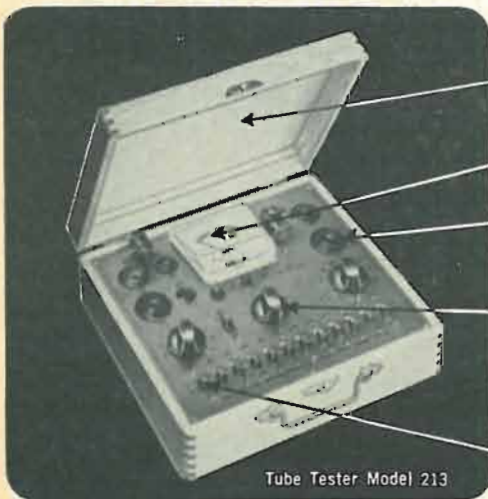

Tube Tester Model 213

Compact, light-weight portability. Use it on the bench or in the field.

Full-view meter gives direct, clear-cut quality indications.

Full complement of sturdy sockets accepts compactron (12-pin), nuvistor, novar, 10-pin, 9-pin, octal, loctal, and miniature tubes.

Three heavy-duty controls for quick set-up of all tests. Check a fistful of tubes in the time it often takes to test one.

Precise programming. Only one socket per tube-base configuration prevents accidental plug-in.

12 slide switches for individual selection of tube pins provides versatility in testing, prevents obsolescence.

THE MODEL 213 saves you time, energy, money ■ Checks for shorts, leakage, intermittents, and quality ■ Tests all tube types including magic eye, regulator, and hi-fi tubes ■ Checks each section of multi-purpose tubes separately ■ Gives long, trouble-free life through heavy-duty components, including permanently etched panel ■ Keeps you up to date with FREE, periodic listings on new tubes as they come out ■ Your best dollar value in a tube tester. Available in high-impact bakelite case with strap: \$31.40 wired; \$20.40 in kit form. Wood carrying case (illustrated) slightly higher.



**ELECTRONIC MEASUREMENTS CORPORATION**  
625 Broadway, New York 12, New York  
Export: Pan-Mar Corp., 1270 Bway, N. Y. 1, N. Y.

EMC, 625 Broadway, New York 12, N.Y.  
Rush me FREE catalog describing all EMC value-loaded test instruments and name of local distributor.

NAME \_\_\_\_\_

ADDRESS \_\_\_\_\_

CITY \_\_\_\_\_

ZONE \_\_\_\_\_ STATE \_\_\_\_\_

**MICROPHONE HEADSETS,** These new headsets permit two-way radio or wired communications in high ambient noise



areas, and are easily adapted to radio transceivers. The transistorized model works directly into common audio line.—Industrial Communications Co.

*Circle 52 on reader's service card*

**3 NEW MICROPHONES, Unispheres.** Model 585SAV has a volume control mounted on the microphone case, enabling the speaker to change the loudness of the PA system to which the mike is connected. Model 565S has an on-off switch as part of the swivel connector assembly. Model 566 (shown in photo)



offers shock mounting to prevent pickup of mechanical vibrations and handling noise. It also features a Cannon-type connector and a combination impedance change (50 or 150 ohms), on-off switch. All of these models are designed to minimize feedback, breath sounds and wind noise. Models 585SAV, 565S, and 566 are \$72.50, \$100.00, and \$140.00 respectively.—Shure Brothers, Inc.

*Circle 53 on reader's service card*

**AM/FM STEREO COMPACT SYSTEMS,** models 1050 and 1030. Model 1050 is a powerful unit which features the Elac/Miracord 50 automatic turntable, EMI model 92 speakers and a Benjamin solid-state receiver with 85-watt (IHF) output. A microphone and instrument input with gain controls permit playing guitar or other instruments through the system and doing "voice over" records. Model 1030 features the Miracord 620 player and EMI 62 speakers and delivers 50 watts (IHF) output. Both units use the Elac 244 compatible mono-stereo magnetic cartridge with dia-

mond stylus and they come with two EMI speakers. Model 1050 is \$499.50 and Model 1030 is \$399.50. Tape re-



order accessory that fits under the cabinet of either model is \$139.50.—Benjamin Electronic Sound Corp.

*Circle 54 on reader's service card*

**AM/FM STEREO MUSIC CENTER,** The LRC-60 solid-state 60-watt receiver features four IC's, FET front end, and a BSR McDonald 500 4-speed automatic stereo turntable with a Pickering V15/AC-3 Dustamatic stereo cartridge. It plays 7, 10, or 12" records at 16%, 33%, 45, and 78 rpm. Impedance: 8-16



ohms; frequency response: 20-20,000 Hz  $\pm$  1dB; tuner FM sensitivity: 1.8  $\mu$ V IHF; capture ratio: 1.25 dB. Provides a full set of audio controls; D'Arsonval tuning meter; automatic FM stereo/mono switching; stereo indicator light; stereo headphone jack; tape recorder jacks; and vernier dial drive. For 117V, 50/60 cycle ac.—Lafayette Radio Electronics Corp.

*Circle 55 on reader's service card*

**AM/FM STEREO RECEIVER** with IC's, Model S-7800. Each IC has 5 silicon transistors in a monolithic semiconductor package. Specs include 2-dB capture ra-



tio, 0.15% distortion at 100% modulation, and 55 dB of AM rejection. Features Field-Effect Transistors in rf and mixer stages for elimination of multiple responses. Receiver delivers 140 watts of music power into 4-ohm loads at 0.6% harmonic distortion. IM distortion is 0.1% at normal listening levels; FM sensitivity, 1.8  $\mu$ V. The unit carries a 3-year warranty for defective parts, including transistors. \$419.50. In walnut-grained leatherette case \$428.50.—Sherwood Electronic Laboratories, Inc. R-E

*Circle 56 on reader's service card*

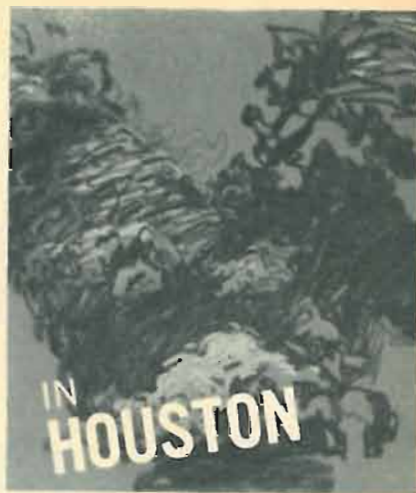

unretouched

**SHURE  
MICROPHONE  
BURNED  
IN  
CLUB  
BLAZE**

This Shure 55SW Unidyne survived a very hot time the night Rosalie's Club burned in Houston. Even though the heat melted the hard plastic section of the switch plate, the microphone was in almost perfect working order. But, since Shure routinely tests microphones at a searing 185° F. for day-long periods, it wasn't particularly surprising that after the fire

**... IT STILL  
WORKED**

© 1967 Shure Brothers, Inc.

*Circle 106 on reader's service card*

## SOME SHOP OWNERS DO MORE BUSINESS THAN OTHERS BY DOING BASIC THINGS LIKE THESE:

 <p><b>1</b> Reading what's new in leading technical magazines.</p>	 <p><b>2</b> Keeping their trucks ready to roll at a moment's notice.</p>	 <p><b>3</b> Arranging to have their phones answered promptly.</p>
 <p><b>4</b> Making sure their caddies are organized and properly stocked.</p>	 <p><b>5</b> Keeping accurate track of their time on each job.</p>	 <p><b>6</b> Smiling . . . often . . . both on and off the job.</p>



**7 INSTALLING SPRAGUE DIFILM® CAPACITORS**

**DIFILM® ORANGE DROP® . . .**  
The world's finest radial-lead capacitor

**DIFILM® BLACK BEAUTY® . . .**  
Ultimate in molded tubulars

These two great Sprague capacitors are expressly made for men who are in the TV service business to do business . . . as it should be done. Both feature the ultimate in tubular capacitor construction to keep you out of call-back trouble:

- Dual dielectric . . . combine best properties of both polyester film and special capacitor tissue.
- Impregnated with HCX® to provide rock-hard capacitor section.
- Because impregnant is solid, there's no oil to leak; no wax to drip.
- Designed for 105°C (220°F) operation without voltage derating.

### DIFILM® ORANGE DROP® Dipped Tubular Capacitors

A "must" for applications where only radial-lead capacitors will fit. Perfect replacements for dipped capacitors used in most leading TV sets. No other dipped tubular capacitors can match them. Double-dipped in rugged epoxy resin for positive protection against extreme heat and humidity.

### DIFILM® BLACK BEAUTY® Molded Tubular Capacitors

World's most humidity-resistant molded capacitors. Feature tough, protective outer case of non-flammable molded phenolic . . . which cannot be damaged in handling or installation. Will withstand the hottest temperatures of any radio or TV set . . . even in the hottest, most humid climates.

For complete listings, ask your Sprague distributor for Catalog C-617, or write to Sprague Products Company, 81 Marshall Street, North Adams, Massachusetts 01247.

**DON'T FORGET TO ASK YOUR CUSTOMERS  
"WHAT ELSE NEEDS FIXING?"**



Circle 109 on reader's service card

## New Antenna Equipment

**UHF-VHF LONG-RANGE ANTENNA, Model CPC-33G,** with a single down-lead receives all 82 channels plus FM. The "Piggy-Back" power pack insures extra reception quality for both

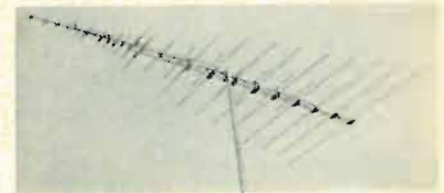

color and black and white, even in fringe areas. A band-splitter is provided for use at the TV set. Finished in K-T Gold Coat, the unit has a built-in-lead-in support and strain relief for durable installation.—Kay-Townes Antenna Co.

Circle 57 on reader's service card

**PERFORATED TV ANTENNA WIRE.** Improves color, uhf and vhf black and white reception. **PERFO 8-0** is constructed with 20-gauge copper conductors. Air spaces between the conduc-



tors allow little signal loss. Impedance is 300 ohms. Available in 500-ft. spools and 50, 75 and 100 ft. pre-cut lengths, the wire is light weight, flexible and less resistant to wind.—Jersey Specialty Co., Inc.

Circle 58 on reader's service card

**75-OHM SOLID COAX, model No. 8221.** Available in standard colors of black, white and gray, this 22-AWG coax has a foam polyethylene vinyl jacket. It is installed easily with RG-59/U connec-

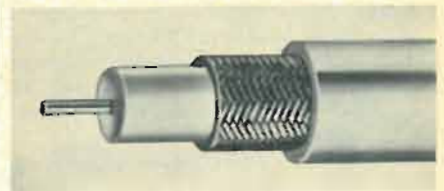

tors and meets MATV, CATV and CCTV requirements for indoor or outdoor use. Features a flexible all-weather jacket and comes in 100-, 500- and 1000-ft lengths as a standard catalog item.—Belden Corp. R-E

Circle 59 on reader's service card

### Miss-Q

Price of book, "Principles of Aerial Design," published by D. Van Nostrand Co. Inc., as reviewed (August 1967), should read \$8.95 and not \$1.75.



## New 5 Band POLICE PORTABLE

**"A SPECTACULAR CHRISTMAS GIFT"**

Hear all police communications: patrol cars, base stations, motorcycles, helicopters. Also tunes Fire Departments, State Highway Patrols, Sheriff's Departments, auto telephones, taxis, all radio equipped vehicles. *Fascinating and exciting listening 24 hours a day!* Marine/Shortwave Band brings in all marine communications. Special Weather Band gives accurate forecasts and reports around the clock. Regular AM Broadcast Band brings in stations ordinary radios never get. *Also plugs into regular house current.*

5 BANDS: 150-175 MC, 30-50 MC, 1.5-4.5 MC  
200-400 KC, 550-1600 KC

Complete with leather case, batteries, antennas, house current adapter. \$129.95. Unconditional 10 day money back return privilege. *Write for Free Booklet.*

Nova-Tech, Inc., 630 Meyer Lane,  
Dept. RE, Redondo Beach, Calif. 90278

Circle 110 on reader's service card

Enjoy the "music-only" programs  
now available on the FM broadcast  
band from coast to coast.

- NO COMMERCIALS •
- NO INTERRUPTIONS •



It's easy! Just plug Music Associated's Sub Carrier Detector into multiplex jack of your FM tuner or easily wire into discriminator. Tune through your FM dial and hear programs of continuous commercial-free music you are now missing. The Detector, self-powered and with electronic mute for quieting between selections, permits reception of popular background music programs no longer sent by wire but transmitted as hidden programs on the FM broadcast band from coast to coast. Use with any FM tuner. Size: 5½" x 9". Shipping weight approx. 7 lbs.

**KIT \$49.50**

(with pre-tuned coils, no alignment necessary)

**WIRED \$75.00** (Covers extra \$4.95 ea.)

Current list of FM Broadcast stations  
with SCA authorization \$1.00

**MUSIC ASSOCIATED**

65 Glenwood Road, Upper Montclair, N. J.  
Phone: (201)-744-3387 07043

Circle 111 on reader's service card

# NEW PRODUCTS

**IN-CONVERTER AND VOLTAGE REGULATOR**, accessories for converting polarity and/or voltage in automotive electrical systems. *In-Converter* has dc input of 6 or 12 V and output of 6 or 12 V of polarity desired, or output of 18 or 24 V



of same polarity as input. *Voltage Regulator* accepts 24-32 vdc and furnishes output of 13 vdc at 14 watts. *Voltage Regulator* (positive ground), \$14.95; (negative ground), \$17.95. *In-Converter*, \$22.95.—E. F. Johnson Co.

Circle 60 on reader's service card

**COLOR TEST TUBE PEDESTALS**, models C21, R19. For 19- and 21-in. TV's. Designed to secure test tube and convergence panel in position for

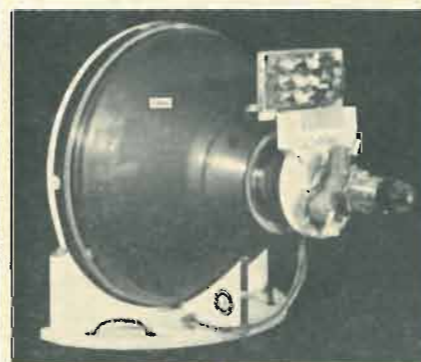

direct hookup. Provide a full picture view in service mirror. C21, for all 70° color tubes, 45 lb; R19, for 21-, 23-, 25-in., 90-92° color tubes. \$14.50—Eight Ball Co. R-E

Circle 61 on reader's service card

### How to Kill Color Ghosts

Improve your color-TV picture by getting rid of annoying ghosts and spurious signals. Learn how the professionals get clean color signals. Find out all about the color ghost situation in our January issue.

DECEMBER 1967

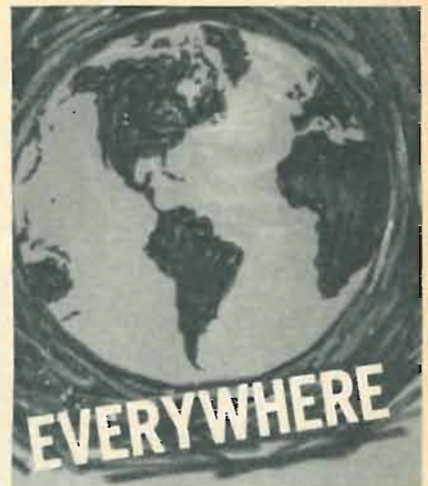

**SHURE**  
**MICROPHONES**  
**KEEP**  
**ON**  
**WORKING**

...ABOVE AND  
BEYOND THE CALL  
OF DUTY

Shure microphones undergo exceedingly rigid and demanding laboratory and field tests—are designed to perform faithfully for years even if subjected to severe use and abuse. They are backed by special know-how and critical quality-control that assure you the utmost in reliability. When the pressure is on they work!

send for complete catalogs:

Shure Brothers, Inc.  
222 Hartrey Ave., Evanston, Ill. 60204

© 1967 Shure Brothers, Inc.  
Circle 106 on reader's service card

**OXFORD**  
The Full Line

**Commercial Sound  
Speaker Source...**



You never compromise with fidelity or quality when you specify Oxford on all your speaker needs.



That's because Oxford electronic and sound engineers know that specialized applications require specialized developments. Oxford doesn't produce just horn or cone types. Oxford studies the application and the problem... develops specific units for specific needs. You're never stuck with trying to pour a bushel basket into a pint measure. Paging and talk-back horns, outdoor hi-fi systems, P.A. systems and other commercial sound installations all find the perfect speaker for the system at Oxford.



Match your skills with the Oxford line of speakers that bring out the best in every sound installation. Write for the Oxford catalog of "speakers for every purpose" today!

**OXFORD TRANSDUCER  
COMPANY**  
A Division of  
Oxford Electric Corporation

3911 S. Michigan Ave.  
Chicago, Ill. 60653

Circle 112 on reader's service card

## NEW LITERATURE

All booklets, catalogs, charts, data sheets and other literature listed here with a Reader's Service number are free for the asking. Turn to the Reader's Service Card facing page 72 and circle the numbers of the items you want. Then detach and mail the card. No postage required!

**TWO-WAY RADIO COMMUNICATIONS SYSTEMS.** This 16-page booklet enables a business/industrial user to select the right system for his requirements. It explains licensing requirements, range expandability and frequency selection, and how to create typical systems from Johnson units. With this booklet potential users of business/industrial radio can design their own two-way radio systems.—E. F. Johnson Co.

Circle 62 on reader's service card

**POTENTIOMETERS, TRIMMERS, DIALS, INSTRUMENT MOTORS, Catalog No. C-67.** This new 120-page catalog covers Amphenol products in depth. Each is shown in a cutaway view with a listing of mechanical, electrical and environmental specs.—Amphenol Corp.

Circle 63 on reader's service card

**THE TAPE CARTRIDGE: How it Began and What It's All About** is a 12-page booklet describing the tape cartridge as a medium of quality sound reproduction and recording for music lovers. It discusses the two types of cartridges—continuous loop and the cassette system. Diagrams make for easy understanding. Tips on proper cartridge handling are given.—Audio Devices, Inc.

Circle 64 on reader's service card

**FREE SAMPLE KIT OF WIRE/CABLE HARNESSES & MARKERS.** Engineers, draftsmen and contractors will be interested in this kit which includes Spiroband, strapping, cable tie and adjustable P-Clip harnessing systems; three types of markers, and a grommet-strip which is cut to size. A business reply card asking for additional information and samples is attached.—Electrovert, Inc.

Circle 65 on reader's service card

**MAGNETIC TAPE RECORDING HANDBOOK, Application Note No. 89.** 44-page handbook covers fundamentals of magnetic tape recording, including FM recording, predetection recording, pulse recording, how electrical signals are stored and recovered from magnetic tape and the function of the bias signal. Characteristics of recording head, tape transport mechanisms, record/reproduce electronics, and the tape itself are also covered.—Hewlett-Packard

Circle 66 on reader's service card

Write direct to the manufacturers for information on the item listed below:

**INTRODUCTION TO TAPE RECORDING, No. a67-21** "Let the Music Get Through to You," a 4-color 24-page booklet, tells how magnetic tape and the tape-recording process work, what to look for when selecting a stereo tape player/recorder, and the advantages of stereo tape libraries over disc collections. 25¢—Ampex Corp. P.O. Box 3728, Chicago, Ill. 60654

RE

80

RADIO-ELECTRONICS

**Yes, you can**



YOU  
CAN  
BUILD

AN ARTISAN TRANSISTORIZED ORGAN  
WITH KITS AND SUB-ASSEMBLIES

**save \$2000 or more**

Easy enough to be fun. Difficult enough to be challenging.

Relax with one of the world's most rewarding hobbies... build a full-size, concert quality transistorized organ. The Artisan Kit Organ has the same rich pipe-like tones, the same features, as the famous Artisan Custom Organ. There's not one bit of difference in tonal beauty, console style, high quality.

10 styles for home, church, school



Write for brochure

Dept. RE  
1372 East Walnut Street  
Pasadena, Calif. 91106

Circle 113 on reader's service card

## TUNAVERTER

**POLICE-FIRE-AIRCRAFT CALLS**  
—TUNABILITY — USABILITY — QUALITY —



TUNABLE, CALIBRATED solid state converters to change your auto and home radios into excellent, sensitive, selective, and calibrated VHF receivers!

"Of all of the converters tested by POPULAR ELECTRONICS there is little doubt that the "TRP TUNAVERTER" is the most versatile." —POPULAR ELECTRONICS MAGAZINE, August 1967.

- 6-1 reduction tuning! • Plug into auto radio!
- HF—2 gang tuning! • American Made!
- VHF—3 gang tuning! • 9 volt btry powered!
- FREE 24" conn. coax! • Size 2 1/4 x 3 1/2 x 4 1/2"
- 2 WEEK MONEY BACK GUARANTEE!

BAND	MODEL	COVERS	OUTPUT	PRICE	
Marine	Marine	2.0-2.85 mc	550 kc	\$19.95 ppd	
SW & WWV	SWL	9.3-10 mc	550 kc	\$19.95 ppd	
CB & 10 M	273	26.9-30 mc	1500 kc	\$29.95 ppd	
6 meters	504	50-54 mc	1500 kc	\$29.95 ppd	
2 meters	1450	144-150 mc	1500 kc	\$29.95 ppd	
Police, fire, & Marine	{ 308 30-38 mc 1500 kc { 375 37-50 mc 1500 kc { 1564 150-164 mc 1500 kc	1500 kc	\$29.95 ppd		
Alircraft		1828	118-128 mc	1500 kc	\$29.95 ppd

Radiation Loop & Extension Antenna for using TUNAVERTER with home and transistor radios \$3.95 ppd

Order from: Fast AIR MAIL add \$.85 ea.

**HERBERT SALCH & CO.** Marketing Division of  
Woodsboro RE12, Texas 78393 Tompkins Radio Products

Circle 114 on reader's service card



# RCA Announces two important new test instruments for service, industrial and lab applications.



## All solid-state battery operated VOLTOHMYST® WV-500A

Eliminate warm-up time! Eliminate zero-shift that can occur in tube-operated voltmeters! RCA's new WV-500A VoltOhmyst is an all solid-state, battery operated, completely portable voltmeter that is ideal for service, industrial and lab applications. Seven overlapping resistance ranges measure from 0.2 ohm to 1000 megohms. Eight overlapping dc-voltage ranges measure from 0.02 volt to 1500 volts (including special 0.5 dc volt range), ac peak-to-peak voltages of complex waveforms from 0.5 volts to 4200 volts, and ac (rms) voltages from 0.1 to 1500 volts. Input impedance of all dc ranges is 1.1 megohms.

All measurements are made with a sturdy, wired-in single-unit probe with fully shielded input cable. The probe is quickly adapted to either dc measurement or ac and resistance measurement by a convenient built-in switch. *And an accessory slip-on high-voltage probe is also available to make possible measurements up to 50,000 dc volts.*

Solid-state reliability and convenience for only \$75.00\*

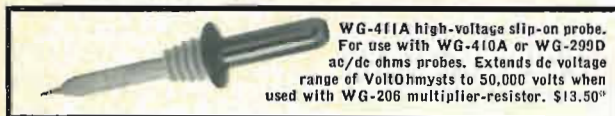

WG-411A high-voltage slip-on probe. For use with WG-410A or WG-299D ac/dc ohms probes. Extends dc voltage range of VoltOhmysts to 50,000 volts when used with WG-206 multiplier-resistor. \$13.50\*



## In-circuit / out-of-circuit TRANSISTOR TESTER WT-501A

Completely portable and requiring no external power source, RCA's new WT-501A tests transistors both in-circuit and out-of-circuit, tests both low and high power transistors, and has both NPN and PNP sockets to allow convenient transistor matching for complementary symmetry applications.

The instrument tests out-of-circuit transistors for dc beta from 1 to 1000, collector-to-base leakage as low as 2 microamperes, and collector-to-emitter leakage from 20 microamperes to 1 ampere. Special low impedance circuitry assures reliable in-circuit testing.

**Collector current is adjustable from 20 microamperes to 1 ampere in four ranges, permitting most transistors to be tested at rated current level. A complete DC Forward Current Transfer Ratio Curve can be plotted.** The three color-coded test leads are provided for in-circuit testing, and for out-of-circuit testing of those transistors that will not fit into the panel socket.

Extra features... RCA reliability... for only \$66.75\*

\*Optional Distributor resale price. All prices subject to change without notice. Prices may be slightly higher in Alaska, Hawaii and the West.

Ask to see them at your Authorized RCA Test Equipment Distributor, or write RCA Commercial Engineering Department L39W, 415 South Fifth Street, Harrison, N.J.



RCA Electronic Components and Devices, Harrison, N.J.

The Most Trusted Name in Electronics

# 1967 ANNUAL INDEX

RADIO-ELECTRONICS January-December 1967 of Vol XXXVIII

## A

Air-War Tactics, Efficiency Testing (Darr)	Apr	51
All-Silicon Regulated Power Supply (Rogers)*§ (Corres)	Aug	16
All-Transistor Mixer-Amplifier (Inman)*§	Aug	54
Amplifiers, see Audio—high fidelity—stereo		
Analog Fundamentals, Digital-to- (Math)	Feb	40
<b>ANTENNA(S)</b>		
Auto (JFD ATV111) (ER)	Mar	68
Breakthrough (NB)	Jul	4
Clinic (Darr)	Apr	22
Coupler, TV/FM (NC)	Jun	90
Grounding (CI)	Oct	26
Height (CI)	Apr	22
Ignition-noise pickup (CI)	Apr	22
Lead-ins, In's and Out's of (Lacy)	Aug	42
Lightning Arrester, CB	Apr	46
Masts, stowing (TTO)	Apr	89
Mounts, Two Useful Pitched-Roof (Pyle and Strand)	Apr	60
Preamp, Mast-Mounted (Schenfeld)	Apr	36
Report	Sep	50
Rotator harness, quick (TTO)	Oct	95
Tower, world's first multiantenna (WN)	Jan	45
Towers on Bonded Roofs, Erecting (Gupton)	Apr	53
Tuning stub, "second chance," (TTO)	Feb	88
Uhf TV (NB)	Sep	4
Appliances, Solid State in Electric (Haskett)	Jun 42; Jul	41
Attenuator, remote-controlled†	May	53
Audio Man's Audio System (Haskett)	Feb	52
<b>AUDIO—HIGH FIDELITY—STEREO, see also Servicing,</b>		
Audio—High Fidelity—Stereo		
Amplifier(s)		
Class-D Hi-Fi (Queen) §	Sep	72
Gain control, transistor variable (NC)	Mar	94
Mixer, All Transistor (Inman)*§	Aug	54
Transistor Power, Convert Heath WA-P2 for (Olson)	May	48
Tremolo circuit for guitar (NC)	Nov	96
Attenuator, remote-controlled†	May	53
Cannonic imitation via hi-fi (NB)	May	6
Components and systems†	Oct	36
Hi-fi		
Hi-Fi, All Around the House	Feb	47
1968	Oct	35
Wider the Band, the Higher the Fi? (Sutheim)	Oct	54
IC's in (NB)	Feb	6
L- and T-Pads, Know Your (Fred)	Sep	36
Mike mixer, 3-channel§ (NC)	Jul	90
Mixer		
Amplifier, All-Transistor (Inman) §	Aug	54
High-Impedance Transistor (Lehman)*§	Mar	40
Mike, 3-channel (NC)	Jul	90
Organ Music, Special Sounds of (Dorf)	Jun	52
PA		
Remote Control for Systems (Darr)	May	47
Switching circuit, audio (NC)	Sep	98
Tape recording from output (CI)	Nov	26
Preamp—Solid-State and High-Z Too (Wherry)*§, Corr	Jan	12
Record players		
Cartridge(s)		
and record to test it (Shure V-15 Type II) (ER)	Aug	71
1968	Oct	38
Systems and Quality (Silke)	Feb	35
Tracking Tests (Ward)	Oct	32
Mono disc to fade (NB)	Aug	4

## KEY TO SYMBOLS AND ABBREVIATIONS

* Construction Articles
† Section of full-length article
§ Transistorized
CI ..... Service Clinic
Corr ..... Correction
Corres ..... Correspondence
ER ..... Equipment Report
NB ..... News Briefs
NC ..... Noteworthy Circuits
Tech ..... Technotes
TTO ..... Try This One
WN ..... What's New
Regular departments not itemized are New Books, New Literature, New Products, What's Your EQ?

## Auto (continued)

Ignition, C-D Solid-State under \$25 (Ward)* § Feb 32; (Corres)	Apr	6
Inverter, Transistorized (Electro Products TI-100A) (ER)	Apr	64
Lights		
On?		
Are You? (NB)	Apr	4
Reminder for Your Car (Montan'e*), (Corres) Mar 16; (Corres)	Jun	14
Reminder, simpler (NC)	Mar	94
Parking, and brake, reminder (NC) Apr 90; Corres	Dec	12
Radio		
Servicing, see Servicing, radio, auto		
Solid-State (Motorola FM106M AM-FM) (ER)	Apr	66
Tachometer/Dwellmaster, Simplest (Sweet*); Corr (Corres)	Jul	14
Tape, fast-forward (NB)	Feb	4
Thieves, Crusade Against (Fasal)*	Mar	47
Voltage regulator, IC (NB)	Nov	22

## Audio—high fidelity—stereo (continued)

Speakers		
Baffle: Speaker-Air Interface (Novak) Jun 49; (Corres)	Sep	12
	Oct	39
Woofing the Tweeter (McCormick)	Nov	42
Stereo		
Adapter, Modern FM (Buegel)*§ Aug 32; (Corres)	Nov	14
Amplifier		
All-Transistor (Knight-Kit KG-895) (ER)	Feb	68
T-40/40 (Meyer)*§, output problem in (CI)	Jun	22
FM Stations Aug 34; (Corres)	Nov	12
Headphone Control Center (Sutheim)*	Nov	35
Hi-fi, Hi-fi, All Around the House	Feb	47
System, Audio Man's (Haskett)	Feb	52
Tape recorder(s)		
Car, fast-forward (NB)	Feb	4
Disc fights (NB)	Apr	6
Flutter Meter, Compact, High-Performance (Hansen) §	Dec	52
Music Center (Ampex 985) (ER)	Dec	62
1968†	Oct	40
Professional (Heathkit-Magnecord AD-16) (ER)	Nov	26
Recording from PA output (CI)	Jun	66
Tape/Slide Synchronizer, Solid-State (Havenhill) §	Dec	32
Tone control, five-channel (NC)	Oct	94
Transistors in, Engineer Talks About (Sutheim) Apr 57; May 55	Nov	96
Tremolo circuit for guitar amplifier (NC)	Nov	96
Audio Tone-Burst Generator (DeSa)* § Jul 44; Corres	Dec	12
<b>AUTO</b>		
Antenna (JFD ATV111) (ER)	Mar	68
Brake		
Laser (NB)	Mar	6
Reminder, parking light and (NC)	Apr	90
Electric		
Bike (NB)	Feb	4
Vehicles being tested (NB)	Jan	4
Electronics in the Modern (Holder)	Nov	43
Highway control system, micromodule (NB)	Oct	16

## B

Baffle: Speaker-Air Interface (Novak) Jun 49; (Corres)	Sep	12
Balls of Fire, Lightning, Plasma and (Smith)	Apr	40
Battery(ies)		
Eliminator from tube tester (TTO)	Aug	95
Fuel Cells—Power for Tomorrow (Smith)	Feb	44
Selection Guide Feb 60; (Corres)	Apr	16
20-year (NB)	Aug	12
Be Brave! Take On Transistor Radios! (Davidson)	Sep	51
Burglars Got It Bad—and That's Good (Darr)	Jun	46

## C

Camera, Solid-State, Is Here (Clifton)	Jun	58
Canada's First Satellite Station (Essex)	Aug	45
Capacitance relay, unusual (NC)	Jan	102
Capacitors, electrolytic ac (NC)	Dec	92
Careers		
Electronic Schools Directory	Dec	40
FCC License . . . and How to Get It (Haskett)	Dec	41
Man's World? Not to These Women (Smyth)	Jul	62
Q and A on an Electronics Career	Dec	40
Technician to Technical Writer (Holder)	Feb	49
Why Servicers Like Servicing (Glass and Tracy)	May	45
Your Future in Electronics (Clifton)	Dec	38
Car Thieves, Crusade Against (Fasal)*	Mar	47
Cartridge(s), see also Audio—high fidelity—stereo, record players		
Systems and Quality (Silke)	Feb	35
Tracking Tests (Ward)	Oct	32
CB, see Radio, CB		
C-D Ignition under \$25, Solid-State (Ward)*§ Feb 32; Corr	Apr	6
Characteristic Plotter, Transistor (Fasal) § Sep 44; (Corres)	Nov	6

Check and Recalibrate Test Gear (Getz) Jul 58

CB Frequencies with BC-221 and a Converter (Gunn)<sup>a</sup> Aug 50

Circuit-Breaker Testing (Darr) Feb 38; (Corres) Jul 14

Circuits from an Experimenter's File, Selected (Scott) May 53

Transistor, from Scratch (Van Houten) Mar 41

Class-D Hi-Fi Amplifier (Queen) § Sep 72

Coils Forms, quick, from tape (TTO) Apr 89

Toroids, Simple Winding Aid for (Null) Mar 81; (Corres) Aug 16

Color, see also Servicing, television, color; Television, color

TV Tube Popularity Guide Jan 100

Voltagages Ain't Circular to Me! (Kirk) Jan 53

Compact, High-Performance Flutter Meter (Hansen) § Dec 52

Computer(s) Airliner lands automatically (NB) May 6

D • U • D, Servicing with (Goodman) (fiction) Apr 39

Read handwritten numbers (NB) Jan 12

R/C (NB) May 4

Thinking? Think Small (Whitmer) May 34

Comsat: Communications in the Space Age (Thrower) May 49

**CONSUMER ELECTRONICS, see also specific subject**

Appliances, Solid State in Electric (Haskett) Jun 42; Jul 41

Burglars Got It Bad—and That's Good (Darr) Jun 46

Consumers Union, Radio-Electronics Interviews (Belt) Jun 60

House of Tomorrow (Ward) Jun 34

Light system, emergency (NC) Nov 96

Show, First, Sound Relay, IC (Greentee)<sup>a</sup> § Jun 57

Jun 77

Consumers Union, Radio-Electronics Interviews (Belt) Jun 60

Controlled Rectifiers, Quick-Checker for (Anglin)<sup>a</sup> Mar 70

Convergence Without a Color Generator (James) Apr 43

Convert Heath WA-P2 for Transistor Power Amp (Olson) May 48

Creative Electronic Servicing (Allen) Sep 39

Crusade Against Car Thieves (Fasal)<sup>a</sup> Mar 47

Crystal switching with diodes (NC) May 98

## D

Designing with Integrated Circuits Mar 32

Development of a Color-TV Signal (Sizer) Jan 59

Digital -to-Analog Fundamentals (Math) Feb 40

Voltmeter, Poor Man's (Todd)<sup>a</sup> §, (Corres) Jan 22; Apr 16

Direct-View 3-D Images! (Smith) Jan 46

Don't Neglect Color-TV Linearity (Mandl) Jan 76

Doorbell extension, unusual (NC) Feb 92

DOTnBAR—Professional Quality Pattern Generator (Lancaster)<sup>a</sup> § Jul 36

Double Feature, Starring Timers (Chesson and Ives)<sup>a</sup> Feb 56

Down with Knob Twisting (Hadrick and Michelotti) Jul 79

D • U • D, Servicing with (Goodman) (fiction) Apr 39

Dummy Load and Rf Meter (Rice and Mueller)<sup>a</sup> Nov 50

## E

**EDITORIALS**

Brainwaves and Electronics (Belt) Sep 2

Can Electronics Get Much Smaller (Belt) Mar 2

Careers in, see Careers

Electronics and the Worlds Beyond (Belt) May 2

FCC, CB and the Public (Haskett) Aug 2

Hands that Feed ETV (Belt) Apr 2; (Corres) Aug 14

Microelectronics and Test Instruments (Scott) Jul 2

Our Electronic Future (Belt) Jun 2

Psychology of Pay TV (Belt) Feb 2

What Price Color? (Belt) Jan 2

Efficiency-Testing Air-War Tactics (Darr) Apr 51

Electric Bike (NB) Feb 4

Vehicles being tested (NB) Jan 4

Electrolytic ac capacitors (NC) Dec 92

Electronic, see also Electronics

Antenna Rotation (Thrower)<sup>a</sup> Aug 47

Calculations, Nomorule in (Fasal) Apr 48

Flash Power of, Measure (Norman) Mar 83

Stave, for \$5 (Keith)<sup>a</sup> Jun 45

Schools Directory Dec 40

**ELECTRONICS, see also Electronic**

Airliner lands automatically (NB) May 6

Air-War Tactics, Efficiency Testing (Darr) Apr 51

Aluminum or copper? (NB) Apr 4

Business outlook (NB) Jun 12

Capacitance relay, unusual (NC) Jun 102

Capacitors, electrolytic ac (NC) Dec 92

Circuits from an Experimenter's File, Selected (Scott) May 53

Computers, see Computers

Consumer, see Consumer Electronics

Consumers Union, Radio-Electronics Interviews (Belt) Jun 60

Digital-to-Analog Fundamentals (Math) Feb 40

Fiber optics at IEEE (NB) Jun 4

Fuel Cells—Power for Tomorrow (Smith) Feb 44

Gamma Goat, Solar-Powered (Hoke)<sup>a</sup> Dec 34

House of Tomorrow (Ward) Jun 34

Hydronic-Radiation Transmitter (Althouse) § May 37

Hydronics, More About Aug 82

Imaginary Numbers Are a Cinch (Crowhurst) May 57

in the Modern Auto (Holder) Nov 43

Infrared Data transmission (NB) Jul 4

Detector, world's smallest (NB) Sep 4

Laser beam converted to green (WN) Jan 45

Insulation, Shrink on the (Jablin) Nov 61

Lamp, Two-Way, Two-Way (Wels)<sup>a</sup> Dec 59

Law and (NB) Jun 6

Light System, emergency (RC) Nov 98

Generator and detector, new (NB) Dec 4

Lightning, Plasma and Balls of Fire (Smith) Apr 46

Microscope, biggest (NB) Nov 22

Midyear Report (Allen) Jun 37

Polarity-reversal hint May 54

Printed-Circuit Boards, How to Make (Montan'e) Nov 62

Reaction-Time Testing of Race Drivers (Davis) May 32

Resistor breakthrough (NB) Oct 16

Rotary Stepping Switches—They're Everywhere (Jaski) Nov 39; Dec 46

Show, First Consumer Switch, noncontact (NB) Jan 12

Time-delay relay, SCRT<sup>†</sup> May 53

Treasure Finder (Rakes)<sup>a</sup> § Nov 32

Tuning, noninductive (NB) Aug 4

Zero-crossing detector, simple (NC) Jun 90

Electronics Culture Corner (Barlow) Mar 43

Engineer Talks About Transistors in Audio (Sutheim) Apr 57; May 55

Erecting Towers on Bonded Roofs (Gupton) Apr 53

Experimenter's Transistor Test Set (Hicke)<sup>a</sup> § Mar 57

Socket markings (Corr) May 12

Exploring the Jungle of Color Troubles (Davidson) Jan 56

## F

FCC License . . . and How to Get It (Haskett) Dec 41

Field Meter, Remote-Reading (White)<sup>a</sup> § Aug 60

First Consumer Electronics Show Jun 57

Five-in-One TV Shop (Smith) Jun 55

Flutter Meter, Compact High-Performance (Hansen)<sup>a</sup> § Dec 52

**FM** Antenna coupler, TV/FM (NC) Jun 90

at Your Fingertips (Buegel)<sup>a</sup> § Jul 47

Receiver boom (NB) Nov 22

Servicing, see Servicing, radio Stereo Adapter, Modern (Buegel)<sup>a</sup> § Aug 32; (Corres) Nov 14

Housewife Builds (Tracy and Spencer) Jun 32

Stations Aug 34; (Corres) Nov 12

Fuel Cells—Power for Tomorrow (Smith) Feb 44

## G

Gamma Goat, Solar-Powered (Hoke)<sup>a</sup> Dec 34

Generators, see Test instruments

Gernsback, Hugo, 1884-1967 Oct 6; (Shunaman) Nov 4

Getting to Know Low-Cost IC's (Scott) Mar 44

## H

Headphone Control Center, Stereo (Sutheim)<sup>a</sup> Nov 35

Hertz not new (Corres) Jan 16

Hi-Fi Hi-Fi, All Around the House Feb 47

1968 Oct 35

Wider the Band, the Higher the Fi? (Sutheim) Oct 54

High fidelity, see Audio—high fidelity—stereo

High-Impedance Transistor Mixer (Lehman)<sup>a</sup> § Mar 40

Holography Direct-View 3-D Images! (Smith) Jan 46

Lasers for (NB) Feb 13

3-D, with ordinary light (NB) Apr 12

Home Movies Time-Compression Machine (Johnson)<sup>a</sup> § Oct 41

House of Tomorrow (Ward) Jun 34

Housewife Builds FM Stereo (Tracy and Spencer) Jun 32

Hydronic-Radiation Transmitter (Althouse)<sup>a</sup> § May 37

Hydronics, More About Aug 82

**IC (s)** Designing with Integrated Circuits Mar 32

Getting to Know Low-Cost IC's (Scott) Mar 44

Glossary (Scott) Mar 85

in receivers (NB) Feb 6

Noninductive tuning (NB) Aug 4

Projects, 30 Basic (Marston) Dec 43

Sine-Square-Saw Generator (Hansen)<sup>a</sup> § Jul 54

Sound Relay (Greenlee)<sup>a</sup> § Jun 77

Voltage regulator (NB) Nov 22

Imaginary Numbers Are a Cinch (Crowhurst) May 57

Incentive Licensing and Distinctive Call Signs Nov 16

**Industrial Electronics** Computers, see Computers

Light system, emergency (NC) Nov 96

Servicing, see Servicing, industrial electronics

Telephone, no-talk (WN) Jan 45

Zip-code monitor (NB) Nov 22

**Infrared** Data transmission (NB) Jul 4

Detector, world's smallest (NB) Sep 4

Laser beam converted to red (WN) Jan 45

**Integrated Circuits, see IC**

in's and Out's of Lead-ins (Lacy) Aug 42

Insulation, Shrink on the (Jablin) Nov 61

Intercom remote will signal master (NC) Feb 92

Interference Nullers, Two (Althouse and Van Houten)<sup>a</sup> § Aug 38

Inverter, Transistorized (Electro Products TI-100A) (ER) Apr 64

It Can't Be All Bad (Prindle) Sep 58

## K

Know Your L- and T-Pads (Fred) Sep 36

## L

L- and T-Pads, Know Your (Fred) Sep 36

Lamp, Two-Way, Two-Way (Wels)<sup>a</sup> Dec 59

**Laser(s)** Brake for cars (NB) Mar 6

Broadband light modulators (NB) Mar 4

Infrared beam converted to green (WN) Jan 45

Latest on (NB) May 12

Medicine and (NB) Aug 4

More on (NB) Feb 12

Sun bottle (NB) Oct 16

Learn Color the Programed Way (Rawlings) Sep 32

Licensing, Incentive, and Distinctive Call Signs Nov 16

Light System, emergency (NC) Nov 96

Generator and detector, new (NB) Dec 4

**Lightning** Arrester, CB Apr 46

Plasma and Balls of Fire (Smith) Apr 40

Lights-on Reminder for Your Car (Montan'e<sup>a</sup>), (Corres) Mar 16; (Corres) Jun 14

Line-voltage indicator† May 53

Luck Is a Lady (Salerno) Aug 67

Lucky Hunts Horizontal Hold (Lemons) Feb 42

## M

Man's World? Not to These Women (Smyth) Jul 62

Mast-Mounted Preamp (Schenfeld) Apr 36

MAT • MOST • MOSFET • UFET • FET: Understanding Solid-State Talk (Turner) Sep 48





Time-delay relay, SCRT†  
 Timers, Double Feature, Starring (Chesson and Ives)\*  
 Time signals (NB)  
 Tone-Burst Generator, Audio (DeSa)\*§  
 Tools and Tests for Transistor TV (Darr)  
 Toroids, Simple Winding Aid for (Null) Mar 81; (Corres)  
 T-Pads, Know Your L- and (Fred)  
 Transmitter Monitor, Professional Quality (Neil)\*§

**TRANSISTOR(IZED)(S)**, see also IC; subject article with § following author's name  
 Audio, Engineer Talks About (Sutheim) Apr 57; May 55  
 Characteristic Plotter (Fasal)\*§ Sep 44; (Corres) Nov 6  
 Circuits from Scratch (Van Houten) Mar 41  
 Fundamentals (Cl) Mar 22  
 Gain control, variable (NC) Mar 94  
 Kink (TTO) Feb 89  
 Mini-Tester, Diode and (Randall) § Oce 46  
 Mixer, High-Impedance (Lehman)\*§ Mar 40  
 MOS FET, What's a (Jackson) Oct 50  
 Plastic—The Future Billions (Bose) Mar 55  
 Power Amplifier, Convert Heath WA-P2 for (Olson) May 48  
 Power Resistor, Need a? (Pepper) Feb 51  
 Radios—Be Brave! Take On! (Davidson) Sep 51  
 Replacement (Admiral) (Tech) Jun 85  
 Slide changer (NC) Aug 94  
 Stereo Generator (Payne)\*§ Jul 32  
 Test Set, Experimenter's (Hicke)\*§ Mar 57  
 Sockat markings (Corr) May 12  
 Three for a penny? (NB) Dec 4  
 TV, Tools and Tests for (Darr) Mar 35  
 Voltmeter, 22-Mehohm FET DC (Jaques)\*§ Oct 44  
 Treasure Finder (Rakes)\*§ Nov 32  
 Triggered Scope for Color (Allen Jan 51; (Corres) Jun 14  
 Trouble That Couldn't Happen (Lowens) Jan 94; Feb 72  
 Troubleshooting Chroma with Vtvm (Babcoke) May 60  
 Tube(s)  
 Brighter color ahead (NB) Mar 14  
 Dimensions, TV (NB) Feb 4

May 53  
 Feb 56  
 Jul 4  
 Jul 44  
 Mar 35  
 Aug 16  
 Sep 36  
 Dec 56  
 May 55  
 Nov 6  
 Mar 41  
 Mar 22  
 Mar 94  
 Feb 89  
 Oce 46  
 Mar 40  
 Oct 50  
 Mar 55  
 May 48  
 Feb 51  
 Sep 51  
 Jun 85  
 Aug 94  
 Jul 32  
 Mar 57  
 May 12  
 Dec 4  
 Mar 35  
 Oct 44  
 Nov 32  
 Jun 14  
 Feb 72  
 May 60  
 Mar 14  
 Feb 4

Tube(s) (continued)  
 Popularity Chart, Color-TV Jan 100  
 Solid-state TV camera pickup "tube" (NB) Feb 4  
 Tester  
 Battery eliminator from (TTO) Aug 95  
 CRT rejuvenator repair (Sencore CR-133) (Tech) Jul 84  
 Sencore MU-140 (ER) Nov 72  
 Twin 200-Watt-Second Solid-State Strobe Slaves (Rice)\*§ Mar 49  
 Two Interference Nullers (Althouse and Van Houten)\*§ Aug 38  
 Two Useful Pitched-Roof Antenna Mounts (Pyle and Strand) Apr 60  
 Two-Way, Two-Way Lamp (Wels)\* Dec 59

**W**  
 Walkie-talkie  
 Power Booster (Crane) § Mar 60; Corres May 16; Corr Apr 6; Jul 4  
 Rule change (NB) Apr 6; Jul 4  
 WANTED: Test Instrument Info (Scott) Jul 50  
 Weather photos, low-cost, by satellite (NB) Jun 12  
 What Happened at Oslo? (Haskett) Jan 41  
 What Kind of Noise Annoys a Tape? (Stillwell) Sep 43  
 Why Servicers Like Servicing (Glass and Tracy) May 45  
 Wider the Band, the Higher the Fi? (Sutheim) Oct 54  
 Wire, stripping enameled (TTO) Jul 91  
 Woofing the Tweeter (McCormick) Nov 42  
 World's Toughest R/C Job (Smith) May 39

**U**  
 Uhf  
 Multiantenna tower, world's first (WN) Jan 45  
 Translator (Lectrotech U-75) (ER) Mar 67  
 Ultrasonic Cleaners, Servicing (Roatger) Sep 62  
 Updating the Self-Holding Relay (Ives) Sep 61

**X**  
 X-ray  
 Callbacks (NB) Aug 6  
 Radiation in TV Sets, What You Should Know About (Lachenbruch) Nov 54

**V**  
 Verifying Amplifier Performance (Sutheim) Jul 80  
 Vertical Sweep Manual (Davidson) Dec 49  
 Video Tapes, Record and Play, with Your TV Set (McGinty)\*§ Apr 32  
 Voltages, Color, Aren't Circular to Me! (Kirk) Jan 53  
 Vom, see Test instruments  
 Vtvm's, see Test instruments, vtvm's

**Y**  
 Your Future in Electronics (Clifton) Dec 38  
 Your Own Shortwave Receiver (Queen)\* Aug 57; (Corr) Sept 12

**Z**  
 Zener Clipper, Nonpolarized (Ives) Feb 55  
 Zero-crossing detector, simple (NC) Jun 90

# FREE!



**BRAND NEW EDITION  
 FALL AND WINTER  
 RADIO-TV  
 ELECTRONICS  
 CATALOG**

THE WORLD'S MOST  
 FAMOUS CATALOG OF  
 ELECTRONIC EQUIPMENT!

YOUR BUYING GUIDE FOR:  
 • Stereo & Hi-Fi Systems & Components • Tape Recorders • Electronic Parts, Tubes, Tools • Phonos & Records • Ham Gear • Test Instruments & Kits • Cameras & Film • PA • Citizens Band • Radio & TV Sets • Musical Instruments

SEND FOR YOURS TODAY!

**MAIL TODAY TO:**

**BURSTEIN-APPLEBEE**  
 Dept. REL, 1012 McGee, Kansas City, Mo. 64106

Name \_\_\_\_\_  
 Address \_\_\_\_\_  
 City \_\_\_\_\_ State \_\_\_\_\_ Zip Code \_\_\_\_\_

DO YOUR FRIEND A FAVOR... ALSO INCLUDE HIS NAME  
 AND ADDRESS IN ENVELOPE WHEN MAILING YOUR REQUEST

Circle 126 on reader's service card

## Coming Next Month . . .

# COLOR TELEVISION

Learn how to get rid of color ghosts and see the best possible picture. Keep up to date on modern high-voltage and shunt-regulator circuits in color sets. Find out how to make purity adjustments, and attack intermit-tents in chroma circuits.

## SERVICING

Take a guided tour of your scope—how to get the most out of it. Learn how to troubleshoot relays and keep them in tiptop condition. Add to your file of case histories in CB transceiver troubles.

## PLUS

Painless dB's—or how to use decibels without knowing logarithms. More applications for an 80-cent IC. Story of an unusual problem (how to use two-way radio in a subway tunnel) and its unusual solution. All these—and more construction projects—you'll find in our January issue.

# TECHNOTES

## RCA CTC 16X HV RECTIFIER

Field reports show that the 3A3-A is being substituted for the 3CA3 high-voltage rectifier in this chassis. The 3A3-A

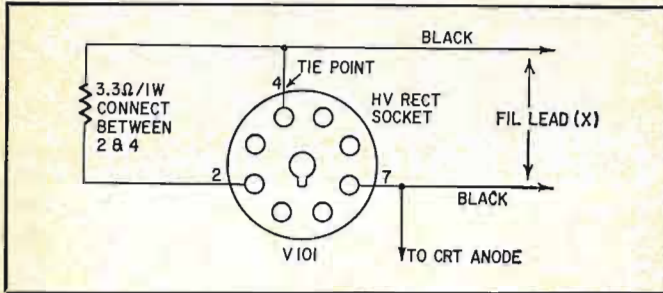

is an improved tube type and is a recommended replacement *provided* a 3.3-ohm, 1-watt resistor is inserted in series with the filament lead.

Some replacement tubes are double-branded 3A3-A/3CA3. These should be considered as type 3A3-A's when

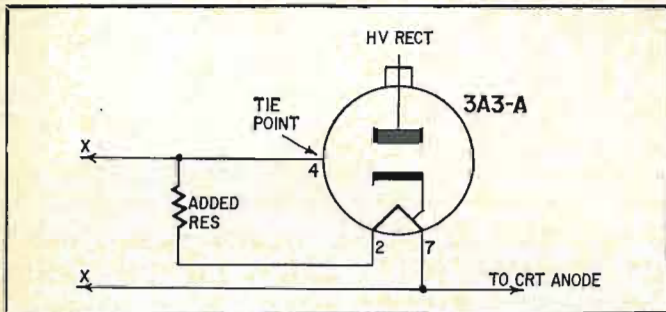

used as replacements in the CTC 16X chassis, requiring the addition of the filament resistor.

The resistor can be installed at the rectifier socket *without removing the chassis*. Transfer the black filament lead from pin 2 to pin 4 (used as a tie point). Connect the resistor between pins 2 and 4 as shown in the diagrams.—*RCA Television Service Tips*

## ADMIRAL TV TEST-JIG ADAPTER

This diagram shows an adapter that enables you to use a color TV test jig having a 7-lead yoke to test current color TV sets employing 4-lead yokes. Plug P1 (Admiral part No.

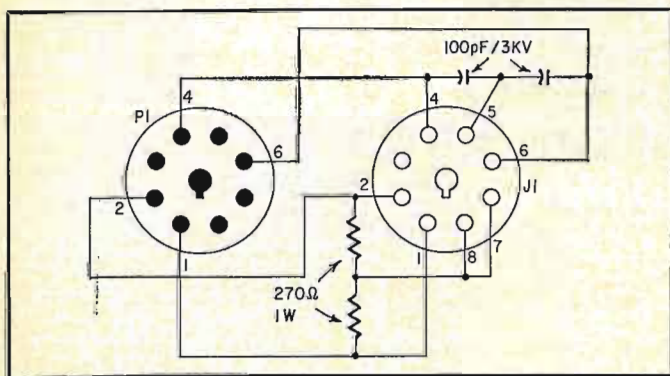

88A23-6) fits 3H10, 4H10, 5H10, 6H10 and 9H10 chassis. Socket (part No. 87A84-2) fits 94D304-1, -2, -3, -4; 94D275-1 and 94D306-1 deflection yokes.—*Admiral Service News Letter*

R-E

Swingin'  
Combo  
for  
Top  
Performance!



## NEW SENCORE SM112B SERVICE MASTER VTVM/VOM

Here it is—the third generation of Sencore's famous Service Master—the two-in-one professional instrument that saves your time, speeds your service work, puts extra profits in your pocket.

- Just one function switch, one range switch and one probe provide all functions of VTVM and VOM.
- Voltage, current and resistance in 33 ranges — for accurate measurements anywhere, anytime.
- VTVM operates from 115v AC for precise bench or lab work; battery powered VOM gives you a 5000 ohms per volt meter.
- Lighted arrows automatically indicate VTVM scales.
- Large, easy-to-read 6-inch two percent meter covers all measurements.
- Handsome new styling in tough, vinyl-clad steel case.
- Optional high voltage probe attaches for measuring up to 30,000 volts DC.

So why use two when one will do — the new Sencore SM112B. Truly professional quality, and still only **\$89.95**  
High Voltage Probe HP118 ..... **\$9.95**



**SENCORE**

NO. 1 MANUFACTURER OF ELECTRONIC MAINTENANCE EQUIPMENT

426 SOUTH WESTGATE DRIVE, ADDISON, ILLINOIS 60101

# Our policies are your best insurance:



Sonotone has been the reliable, quality name in replacement phono cartridges since 1947. We've made and sold 20 million of them. When you service with Sonotone cartridges, you can be assured you are servicing with the best. *We'll stake our name on that.*

REPLACE WITH SONOTONE CARTRIDGES. There's a complete line for immediate replacement of virtually every cartridge in use today. Prove it to yourself — fill out and mail coupon TODAY for your free copy of Sonotone's 1967 "computer-programmed" cartridge replacement manual.

Send today for complete information:

Sonotone Corporation, Dept. 107  
Elmsford, New York 10523

Just fill out and mail this coupon for your free copy of Sonotone's 1967 "computer-programmed" cartridge replacement manual.

YOUR NAME \_\_\_\_\_

ADDRESS \_\_\_\_\_

CITY \_\_\_\_\_

STATE \_\_\_\_\_ ZIP \_\_\_\_\_

Circle 116 on reader's service card

# NEW SEMICONDUCTORS

## FIELD-EFFECT DIODES

The Motorola 1N5283 through 1N5314 series of current regulators are field-effect diodes that establish a constant current flow regardless of applied voltage. They are the analog of the Zener diode which establishes a constant voltage independent of current.

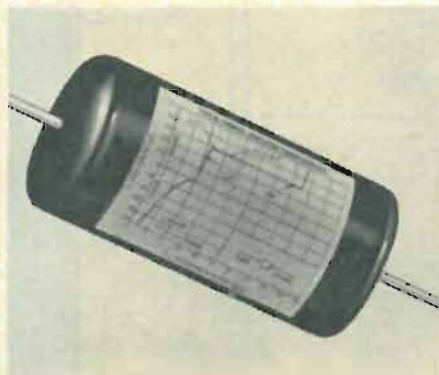

The diodes are ideal for use as constant-current sources for differential amplifiers, ramp generators and for

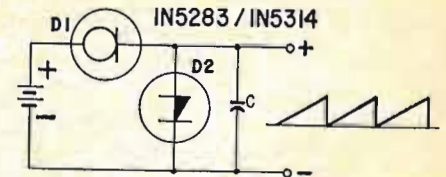

transistor biasing. In voltage-reference circuits, the current regulator can supply a temperature-compensated Zener diode with a constant current to limit voltage changes caused by large swings in an unregulated circuit.

The current regulators can be used to simplify the design of sawtooth and ramp generator circuits. The diagram shows a simple sawtooth generator with a linear positive-going ramp. D1 is the current regulator diode and D2 is a 4-layer diode. The period of one cycle of the oscillator (T) is  $C \times V_{BR}/I_F$ ; where  $I_F$  is the pinch-off current of D1, C is the value of the capacitor in  $\mu F$  and  $V_{BR}$  is the breakover voltage of the 4-layer diode.

The diodes are in a DO-7 glass

# "CHRISTMAS SALE" YOU-HELPED US BUILD A BIG INVENTORY! THESE AMAZING BUYS-ARE YOUR DIVIDENDS

FREE GIFT WITH EVERY ORDER      FREE \$1 BUY WITH EVERY 10 YOU ORDER      Only applies to "\$1" Buys

- TAPE RECORDER — assorted types good, bad, broken, as-is, potluck \$4
- TRANSISTOR RADIO *asst type* good, bad, broken, as-is, potluck \$1.50
- 50 — TUBE CARTONS (colored) assorted sizes for Popular Tubes or—50 of any size you select .. \$1
- 10 — ASSORTED TUBES Radio, Television and Industrial .. \$1
- ALL AMERICAN TUBE KIT Top Standard Brand — 12BA6, 12BE6, 12AV6, 500C5, 35W4 ... \$2
- 1 — LB SPOOL ROSIN-CORE SOLDER 40/60 top quality .... \$1
- 2—G.E. PIECES OF EQUIPMENT stacked with over 200 useful parts \$1
- 100 — MIXED DEAL "JACKPOT" Condensers, Resistors, Surprises .. \$1
- 10—ASSORTED SLIDE SWITCHES SPST, SPDT, DPDT, etc. .... \$1
- 20 — EXPERIMENTER'S COIL "JACKPOT" assorted for 101 uses \$1
- 20—ASST. PILOT LIGHTS #44, 46, 47, 51, etc. .... \$1
- 50 — ASST. DISC CERAMIC CONDENSERS popular numbers .. \$1
- 10 — ASST. RADIO ELECTROLYTIC CONDENSERS ..... \$1
- 20 — STANDARD TUBULAR CONDENSERS .047-800v ..... \$1
- 3—½ MEG VOLUME CONTROLS with switch, 3" shaft ..... \$1
- 25 — SYLVANIA HEAT SINKS for Transistor and other circuits .. \$1
- WIRE "JACKPOT" good variety \$1
- 25 — TUNGSOIL FLASHLIGHT BULBS #T416, bayonet, 3.3 v, 2w \$1
- 50 — ASSORTED MYLAR CONDENSERS popular selected types \$1
- 40 — ASSORTED TV KNOBS all standard types, \$20 value ... \$1
- 7 — ASST. TV ELECTROLYTIC CONDENSERS popular selection .. \$1
- 10 SETS — DELUXE PLUGS & JACKS *asst.* for many purposes .. \$1
- 10 — SETS PHONO PLUGS & PIN JACKS RCA type ..... \$1
- 10 — SURE-GRIP ALLIGATOR CLIPS 2" plated ..... \$1
- 50 — RADIO & TV SOCKETS all type 7 pin, 8 pin, 9 pin, etc. \$1
- 50 — ASSORTED #3AG FUSES popular ampere ratings ..... \$1
- 100 — STRIPS ASSORTED SPAGHETTI handy sizes ..... \$1
- 100—ASSORTED RUBBER GROMMETS best sizes ..... \$1
- 10—ASSORTED VOLUME CONTROLS less switch ..... \$1
- 7—ASSORTED VOLUME CONTROLS with switch ..... \$1
- \$15.00 RADIO PARTS "JACKPOT" handy assortment ..... \$1

**RCA 110° FLYBACK TRANSFORMER**

We scooped the Market Latest type — standard for all 110° TV's

RCA's design of large Coil produces 18KV — assuring adequate width

Incl Schematic Diagram application for any TV

List price \$13.90

Your price .. \$3

10% off in lots of 3

110° TV DEFLECTION YOKE for all type TV's incl schematic same as Thorlarsen Y502 list \$20 \$3

"COMBINATION SPECIAL" RCA 110° FLYBACK plus 110° DEFLECTION YOKE .. \$5

- 90° FLYBACK TRANSFORMER for all type TV's incl schematic \$2
- 90° TV DEFLECTION YOKE for all type TV's incl schematic .. \$2
- 70° FLYBACK TRANSFORMER for all type TV's incl schematic \$1
- 70° TV DEFLECTION YOKE for all type TV's incl schematic \$1
- 20—ASSORTED TV COILS I.F. video, sound, ratio, etc. .... \$1
- 4 — TV ALIGNMENT TOOLS most useful assortment ..... \$1
- \$15.00 TELEVISION PARTS "JACKPOT" best buy ever ..... \$1

**MARKET SCOOP COLUMN**

Famous Electrolytic Condensers sparkling new—all sold at 3 for \$1

<input type="checkbox"/> 3 — 50/50/50mfd — 450/250/250v .....	\$1
<input type="checkbox"/> 3 — 100/80/20mfd — 300/300/300v .....	\$1
<input type="checkbox"/> 3 — 250/200/50mfd — 175/175/175v .....	\$1
<input type="checkbox"/> 3 — 80/40/20mfd — 300/300/300v .....	\$1
<input type="checkbox"/> 3 — 200/200/40mfd — 200/150/150v .....	\$1
<input type="checkbox"/> 3 — 80/40/40mfd — 150/150/150/25v .....	\$1
<input type="checkbox"/> 3 — 1000/1000/500mfd — 35/35/20v .....	\$1
<input type="checkbox"/> 3 — 50/10/160mfd — 450/400/250v .....	\$1
<input type="checkbox"/> 3 — 40/40/40mfd — 450/300/150v .....	\$1
<input type="checkbox"/> 3 — 30/200/4/4mfd — 475/475/475/25v .....	\$1
<input type="checkbox"/> 3 — 150/100/100mfd — 350/350/300v .....	\$1
<input type="checkbox"/> 3 — 50/40/30/30mfd — 450/350/300/300v .....	\$1
<input type="checkbox"/> 15/15/15mfd — 450/250/100v .....	\$1

IMMEDIATE DELIVERY . . . Scientific light packing for safe delivery at minimum cost.  
HANDY WAY TO ORDER: Pencil mark or write amounts wanted in each box, place letter F in box for Free \$1 BUY. Enclose with check or money order, add extra for shipping. Tearsheets will be returned as packing slips in your order, plus lists of new offers.

Name .....

Address .....

Cost of goods .....

Shipping estimated .....

TOTAL .....

Please specify refund on shipping overpayment desired:  CHECK  POSTAGE STAMPS  MERCHANDISE (our choice) with advantage to customer

**BROOKS RADIO & TV CORP., 487 Columbus Ave., New York, N. Y. 10024** TELEPHONE 212-874 5600



# AND MICROCIRCUITS

cartridge. They have a peak operating voltage rating of 100, power dissipation is 600 mW and cover 32 current ranges. Minimum dynamic impedance for diodes in the series ranges from 25.0 megohms for the 1N5283 (a 0.22-mA device) to 235,000 ohms for the 1N5314, a 4.7-mA unit.

The price is \$4.90 in lots of 100 and up—but can be expected to drop as usage increases.

## TRIAC WITH INTEGRAL TRIGGER

The RCA 40431 and 40432 Triacs are gate-controlled full-wave ac silicon switches with built-in triggers. They are intended for phase control of ac loads in such applications as light dimming, speed controls for universal and induction motors and in heating controls.

They are sealed in modified TO-5 packages which are tin-plated so they can be soldered to heat sinks.

The 40431 is for applications requiring repetitive peak off-state voltages

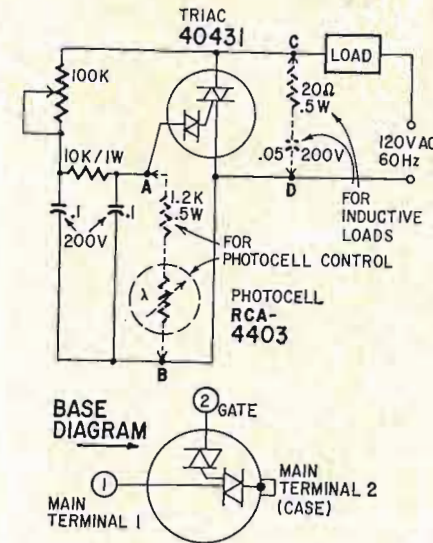

up to 200 and an on-state rms current up to 6 amps with case temperatures up to 75°C. The 40432 is for off-state voltages up to 400 under the same conditions. R-E

# Why Do You Read So Slowly?

A noted publisher in Chicago reports there is a simple technique of rapid reading which should enable you to double your reading speed and yet retain much more. Most people do not realize how much they could increase their pleasure, success and income by reading faster and more accurately.

According to the publisher, anyone, regardless of his present reading skill, can use this simple technique to improve his reading ability to a remarkable degree. Whether reading stories, books, technical matter, it becomes possible to read sentences at a glance and entire pages in seconds with this method.

To acquaint the readers of this publication with the easy-to-follow rules for developing rapid reading skill, the company has printed full details of its interesting self-training methods in a new booklet, "How to Read Faster and Retain More" mailed free to anyone who requests it. No obligation. Send your name, address, and zip code to: Reading, 835 Diversey Parkway, Dept. 684-01D, Chicago, Ill. 60614. A postcard will do.

Circle 118 on reader's service card

## Raleigh AM-FM RADIO

No. 1682



An Elegance in Ebony & Chrome  
Unsurpassed in Clarity & Volume  
16 Transistors — a Powerhouse of Quality Reception with AFC  
Operates on Batteries & Electric  
Batteries & AC Adapter included  
7 1/2" x 4 1/4" x 2" weight 4 lbs  
Money refund if not better than any Known Brand, selling for even twice the price

Complete... \$23.75

## Raleigh WALKIE TALKIE

Deluxe Professional Transceiver Set



No. 1122  
● 11 TRANSISTORS  
● RANGE 5 MILES  
● MIKE & SPEAKER separate  
● SQUELCH CONTROL  
● BEEP CONTROL

Channel 7 27.035mc  
Uses 6 Penlike Batteries  
9" x 2 3/4" x 2 3/4" 7 lbs  
Complete SET \$49.66

AC Adapter \$3.00 extra

## Raleigh WALK TALK

No. 91



9 TRANSISTORS  
RANGE 3 MILES  
130 MW OUTPUT  
USES 9v BATTERY

For Home — Business  
TV Antenna orienting  
Intercom — Outings  
Meets approval all over. 6" x 2 3/4" x 1 3/4" 4 lbs.

Complete SET \$29.97

## Mastercraft RADIO

Deluxe No. 606



We tested hundreds of brands of 6 Transistor Radios side-by-side and picked the:

- BEST LOOKING
- BEST PERFORMER
- BEST PRICE

HERE IT IS!

4 1/4" x 2 1/2" x 1 1/4"

\$3.99

Red, White, Blue, Black mention alternate color Complete

1000—ASST. HARDWARE KIT \$1 screws, nuts, washers, rivets, etc.

300 — ASSORTED HEX NUTS \$1 2/66, 4/40, 5/40, 6/32, 8/32 ..

250—ASST. SOLDERING LUGS \$1 best types and sizes .....

250—ASST. WOOD SCREWS \$1 finest popular selection .....

250 — ASST. SELF TAPPING SCREWS #6, #8, etc. ....

150—ASST. 6/32 SCREWS and 150 6/32 HEX NUTS ....

150—ASST. 8/32 SCREWS and 150—8/32 HEX NUTS ....

150—ASST. 2/56 SCREWS and 150—2/56 HEX NUTS ....

150—ASST. 4/40 SCREWS and 150—4/40 HEX NUTS ....

150—ASST. 5/40 SCREWS and 150—5/40 HEX NUTS ....

500—ASSORTED RIVETS most useful selected sizes .....

500—ASSORTED WASHERS most useful selected sizes .....

100—ASST. RUBBER BUMPERS \$1 for cabinet bottoms & other uses ..

UNIVERSAL 4" PM SPEAKER \$4.95 Alnico 5 magnet, quality tone ..

100 — ASST. RADIO KNOBS \$1 all selected popular types .....

100 — ASST. TUBULAR CONDENSERS .001 to .47 to 600 v. ..

3—ELECTROLYTIC CONDENSERS most popular number 50/30—150v

15 — G.E. #NE-2 TUBES Neon Glow Lamp for 101 uses ..

CLEAN UP THE KITCHEN "JACK-POT" Big Deal only one to a customer .....

CHAPT ZU DI MITZIA "JACK-POT" double your money back if not completely satisfied .....

50 — ASST. TERMINAL STRIPS all types, 1-lug to 8-lug .....

25 — INSTRUMENT POINTER KNOBS selected popular types ..

5 — I.F. COIL TRANSFORMERS sub-min for Transistor Radios ....

5 — AUDIO OUTPUT TRANSFORM Sub-min for Trans Radios

4 — TOGGLE SWITCHES SPST, SPDT, DPST, DPDT .....

32—TEST PROD WIRE deluxe quality, red or black ....

10 — STANDARD TRANSISTORS \$1 NPN & PNP 2N404, 2N414, etc.

10—ASSORTED DIODE CRYSTALS \$1 1N34, 1N48, 1N60, 1N64, etc. ..

3 — TOP BRAND SILICON RECTIFIERS 1 amp, 1000 PIV .....

5 — TOP HAT SILICON RECTIFIERS 500ma-400v — big value ..

100—ASST 1/4 WATT RESISTORS stand. choice ohmages, some in 5%

100 — ASST 1/2 WATT RESISTORS stand. choice ohmages, some in 5%

70 — ASST 1 WATT RESISTORS stand. choice ohmages, some in 5%

35 — ASST 2 WATT RESISTORS stand. choice ohmages, some in 5%

50 — PRECISION RESISTORS asst. list-price \$50 less 98% ..

20 — ASS'TED WIREWOUND RESISTORS, 5, 10, 20 watt ....

100 — ASST. MICA CONDENSERS some in 5% .....

5 — PNP TRANSISTORS general purpose, TO-5 case .....

5 — NPN TRANSISTORS general purpose, TO-5 case .....

10 — G.E. SAPPHIRE NEEDLES 4G, VR-11, etc. (\$25.00 value) ..

## ELITE RADIO-PHONO COMB.

Elite No. 300 Portable — "Has Everything"

Solid State Circuit — All Transistorized

Speeds — Plays all Records

Plays on Batteries — Plays on Electric

Good Clarity & Volume — Latest Type Radio

Beautiful modern in 2-tone walnut & gray

Compact 11 1/2" x 11 1/2" x 3" — weight 8 lbs.

Handy — for Home, Travel, Beach, Party

This \$55.00 Value is sold on a money-back-basis

\$29.45 Complete



IBM COMPUTER SECTIONS

8 assorted Units we sell for \$1 are loaded with over 150 valuable parts.

Incl. — Transistors Condensers, Resistors, Heat Sinks, Diodes, Etc.

8 for \$1 100 for \$10

BONANZA "JACKPOT" not gold, not oil, but a wealth of electronic Items—Money-Back-guarantee .. \$5

# Be Sure and See These Brand-New GL-TAB Books at Your Parts Distributor!



**SERVICING TV RECEIVER CIRCUITS**—Just the kind of "how-to-do-it" handbook every practicing TV service technician should have. Contains the TV service data most needed for troubleshooting both monochrome and color receivers, all in one handy volume. Emphasis is on practical data which can be used in the home or at the service bench. 224 pps., 34 chapters. No. 414 Paperback \$2.95



**ELECTRONIC ENGINEERING MEASUREMENTS FILEBOOK**—A single source of measurement principles and practices. Describes detailed techniques, complete with test setups, waveforms, mathematical analyses, etc., for measuring. One of the most complete collections of its type available today, containing 60 complete "How-to-Measure" sections. 256 pps. No. T131 Paper \$4.95



**TEN-MINUTE TEST TECHNIQUES FOR ELECTRONICS SERVICING**: Describes how trouble in any piece of electronic equipment may be pinpointed quickly and easily. Step-by-step techniques are outlined for localizing trouble to an improperly operating stage and then to the defective component itself, using a minimum amount of test equipment. 176 pps., 125 illus. No. 424 Paperback \$2.95



**TV TROUBLESHOOTER'S HANDBOOK**: A carefully-planned reference source of over 350 different, tried and tested solutions to "tough-dog" TV servicing problems. A complete digest of late-model TV receiver troubles and cures, new and unusual circuits and descriptions of how they work, field and factory changes, recurring defects, etc. 125 illus. No. T-401 Paperback \$2.95

defective component itself, using a minimum amount of test equipment. 176 pps., 125 illus. No. 424 Paperback \$2.95

work, field and factory changes, recurring defects, etc. 125 illus. No. T-401 Paperback \$2.95

## OTHER GERNSBACK LIBRARY BOOKS . . . practical and authoritative aids . . .

### BASIC SERIES

- Basic Transistor Course by Paul R. Kenian No. 111 Paperback \$4.10
- Basic Oscillator Handbook by Norman H. Crowhurst No. 130 Paperback \$2.95
- Basic TV Course by George Kravitz No. 105 Paperback \$4.10
- Basic Radio Course by John T. Frye No. 104 Paperback \$4.10
- Basic Math Course for Electronics by Henry Jacobwitz No. 100 Paperback \$4.50

- Jack Darr's Service Clinic compiled by James Belt No. 133 Paperback \$2.95
- Rapid Radio Repair by G. Warren Heath No. 78 Paperback \$2.90
- Servicing Transistor Radios by Leonard D'Airo No. 76 Paperback \$2.90
- Radio TV Repair by G. Warren Heath No. 60 Paperback \$2.90
- Servicing Record Changers by Harry Mileaf No. 59 Paperback \$2.90

### TRANSISTORS

- Pinpoint Transistor Troubles in 12 Minutes by L. Garner No. 430 Hardcover \$6.95
- Getting Started with Transistors by Louis E. Garner, Jr. No. 116 Paperback \$3.95
- Transistor Projects by Editors of Radio-Electronics No. 89 Paperback \$2.90
- Transistors No. 94 Paperback \$1.95
- Transistor Circuits by Rufus P. Turner No. 63 Paperback \$2.75
- Transistor Techniques No. 61 Paperback \$1.50
- New Skill-Building Transistor Projects and Experiments by Louis E. Garner, Jr. No. 129 Paperback \$2.95
- Fundamentals of Semiconductors by M. G. Scroggie No. 92 Paperback \$2.95

### HOBBIES

- Fun with Radio-Controlled Models by Edward L. Safford, Jr. No. 106 Paperback \$3.20
- Radio-Control Handbook by H. G. McEntee No. 93 Paperback \$2.65
- Fun with Electricity by Thomas Kennedy, Jr. No. 83 Paperback \$2.65
- Model Radio-Control by Edward L. Safford, Jr. No. 74 Paperback \$2.65
- Electronic Puzzles and Games by Matthew Mandl No. 70 Paperback \$1.95
- Electronic Hobbyists' Handbook by Rufus P. Turner No. 69 Paperback \$2.50

### DATA BOOKS

- Charts and Nomographs for Electronics Technicians and Engineers by Donald W. Moffat No. 121 Clothbound \$5.95

- Electronics Data Handbook by Martin Clifford No. 118 Paperback \$2.95
- Electronic Design Charts by Norman Crowhurst No. 110 Clothbound \$5.95

- Handbook of Electronic Tables by Martin Clifford No. 125 Paperback \$2.95

### SERVICING

- New Way to Service Color TV by C. Babcock No. 136 Paperback \$3.25
- Horizontal Sweep Servicing Handbook by Jack Darr No. 115 Paperback \$4.10
- Pinpoint TV Troubles in 12 Minutes by H. Manly No. 428 Hardcover \$6.95
- Radio Servicing Made Easy by Leonard C. Lane No. 107 2 vol. Paperback \$7.20
- Servicing AGC Circuits by Harry E. Thomas No. 126 Paperback \$3.95
- Practical TV Troubleshooting No. 102 Paperback \$2.35
- Servicing Sync Circuits by Art Margolis No. 134 Paperback \$2.95

### TEST INSTRUMENTS

- Test Instruments for Electronics by Martin Clifford No. 131 Paperback \$2.95
- How to Test . . . Almost Everything Electronic by Jack Darr No. 132 Paperback \$2.95
- The Oscilloscope by George Zwick No. 108 Paperback \$3.65
- How to Get the Most out of your VOM by Tom Jaski No. 85 Paperback \$2.90
- Oscilloscope Techniques by Alfred Haas No. 72 Paperback \$2.90
- The VTVM by Rhys Samuel No. 57 Paperback \$2.50
- Probes for Test Instr's. by Bruno Zucconi & Martin Clifford No. 54 Paperback \$2.50

### THEORY & FUNDAMENTALS

- Elements of Electron Physics by Norman Crowhurst No. 113 Paperback \$3.95
- Learn Electronics By Building by John Schroeder No. 112 Paperback \$3.85
- Industrial Electronics Made Easy by Tom Jaski No. 99 Paperback \$3.95

### HIGH FIDELITY

- Hi-Fi Troubles by Herman Burstein No. 120 Paperback \$3.95
- Designing and Building Hi-Fi Furniture by Jeff Markell No. 79 Paperback \$2.90
- Elements of Tape Recorder Circuits by Herman Burstein and Henry C. Pollak No. 67 Paperback \$2.90
- Understanding Hi-Fi Circuits by Norman Crowhurst No. 64 Paperback \$2.90
- Maintaining Hi-Fi Equipment by Joseph Marshall No. 58 Paperback \$2.90



## SINGLPAK MANUAL

### TV SERVICE MANUAL

# 79¢

**ONLY SINGLPAK GIVES YOU AUTHENTIC FACTORY SERVICE DATA**



SINGLPAK MANUALS, BLUE RIDGE SUMMIT, PA. 17214

CONTAINS

SCHEMATICS  
PARTS LISTS  
CHASSIS VIEWS  
PARTS LOCATIONS  
TUNERS (UHF-VHF)  
PHOTOS  
TUBE COMPLAINTS  
ADJUSTMENTS  
ALIGNMENTS  
WAVE FORMS  
VOLTAGES  
REVISIONS  
REMOTES  
SUPPLEMENTS

. . . and, don't forget to see SINGLPAK MANUALS®

Here's a TV Service Manual with all data in a single pack!

Only SINGLPAK Manuals give you authentic Factory Service Data for over 8,000 TV sets—black and white or color—in SINGLE MANUAL packs.

And the cost . . . just 79¢!

No need to pay for several manuals to get the one manual you want.

SINGLPAK Manuals are now available for the 10 most popular makes introduced from 1955 to 1965—fulfills 90% of TV service data needs for this period. **SEE YOUR DISTRIBUTOR** If he doesn't have them send us his name

- SINGLE PAK MANUALS AVAILABLE FOR 1955-65 SETS BY:**

  - ADMIRAL
  - EMERSON
  - GENERAL-ELECTRIC
  - MAGNAVOX
  - MOTOROLA
  - PHILCO
  - RCA
  - SYLVANIA
  - WESTINGHOUSE
  - ZENITH

If your distributor does not have the books you wish in stock, feel free to use the handy coupon below to order.

### NO RISK COUPON — MAIL TODAY

TAB Books, Blue Ridge Summit, Pa. 17214  
Please send me the books listed below:

I enclose \$..... (Save postage by remitting with order)  
 Please invoice on 10-day FREE trial

Name .....

Company .....

Address .....

City ..... State ..... Zip .....

My distributor is: ..... RE 127

Circle 119 on reader's service card

## Build A Tape/Slide Synchronizer

continued from page 33

this is not important as there is plenty of signal for recording.

### Construction

The parts layout is not critical as all circuits are low impedance. Figs. 6 and 7 are top and underside views and show the location of the few parts used.

The Triac is conveniently mounted on the small aluminum plate which is insulated from and fastened to the case with 1/2" insulated, threaded spacers. Transformer T1 is mounted on the opposite side of the cabinet (Fig. 7). P1, J1, J2 and J3 are mounted on the front. As Fig. 6 shows. R3, S1 and S2 are mounted on the top of the case.

Resistor R1 should be chosen to produce a 1-volt sync signal. The resistance value will depend on the voltage value and the amount of current drawn by the slide-changer motor or solenoid. If the motor draws about 0.3 amp, which is normal for home-type changers, R1 should be 3 ohms. Check the nameplate on your projector to find

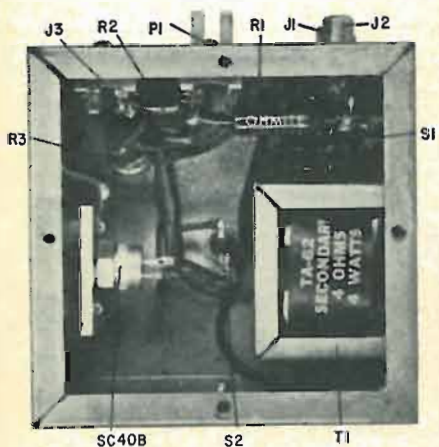

Fig. 7—Parts placement isn't critical within the box as the circuit is chiefly low impedance. Mount Triac carefully.

out how much current it draws. This figure may include the projector lamp wattage, which you must subtract. Better still, use an ac voltmeter across R1 and try different values until you come up with a 1-volt signal.

You will need a two-wire power cable with a receptacle to mate with P1 on one end. The other end of the cable should match the slide-changer remote socket. For the sync connections to the tape recorder, use phone plug on one end, and whatever you need on the other to match the recorder jacks. **R-E**

**WORLD'S FINEST**  
**5-CORE SOLDER**

**ERSIN MULTICORE**  
**NEW EASY DISPENSER PAK** ONLY **69¢**

BUY IT AT RADIO-TV PARTS STORES  
MULTICORE SALES CORP. WESTBURY, N.Y. 11590  
Circle 120 on reader's service card

**COMPLETE TUNER OVERHAUL**  
**995**  
**ALL LABOR AND PARTS**  
(EXCEPT TUBES & TRANSISTORS)\*

VHF UHF COLOR UV TRANSISTOR

**COLOR TUNERS** GUARANTEED COLOR ALIGNMENT — NO ADDITIONAL CHARGE

Simply send us the defective tuner complete; include tubes, shield cover and any damaged parts with model number and complaint. Your tuner will be expertly overhauled and returned promptly, performance restored, aligned to original standards and warranted for 90 days.  
UV combination tuner must be single chassis type; dismantle tandem UHF and VHF tuners and send in the defective unit only.  
Exact Replacements are available for tuners unfit for overhaul. As low as \$12.95 exchange. (Replacements are new or rebuilt.)  
And remember—for over a decade Castle has been the leader in this specialized field . . . your assurance of the best in TV tuner overhauling.

**CASTLE**  
TV TUNER SERVICE, INC.

5715 N. Western Ave., Chicago 45, Illinois  
41-96 Vernon Blvd., Long Island City 1, N. Y.

For service in Canada write to Chicago or use reader service card in this magazine.  
\*Major parts are charged extra in Canada.

Circle 121 on reader's service card

Radio-Electronics' 5th Annual Color TV issue coming next month. Learn how to kill color ghosts, how to whip intermittent trouble in a color TV set, how to get more life out of high-voltage circuits and how to improve purity.

# ELECTRONICS

## Engineering-Technicians

**Bachelor of Science Degree, 30 Months**  
**Save Two Years' Time**

- Radio-Television Plus Color Technician (12 Months)
- Electronics Engineering Technology (15 Months)
- Electronics Engineering (B.S. Degree)
  - Electrical Engineering (B.S. Degree)
  - Mechanical Engineering (B.S. Degree)
  - Civil Engineering (B.S. Degree)
  - Architecture (B.S. Degree) (36 Months)

The Nation's increased demand for Engineers, Electronic Technicians, Radio TV Technicians is at an all time high. Heald Graduates are in demand for Preferred High Paying Salaries. Train now for a lucrative satisfying lifetime career.

**Approved for Veterans**  
**DAY AND EVENING CLASSES**

Write for Catalog and Registration Application. New Term Starting Soon.

Your Name .....

Address .....

City .....

State .....



1215 Van Ness Avenue  
San Francisco, California

Circle 122 on reader's service card

# Olson®



Fill in coupon for a **FREE** One Year Subscription to **OLSON ELECTRONICS' Fantastic Value Packed Catalog—Unheard of LOW, LOW PRICES on Brand Name Speakers, Changers, Tubes, Tools, Stereo Amps, Tuners, CB, Hi-Fi's, and thousands of other Electronic Values. Credit plan available.**

NAME \_\_\_\_\_  
 ADDRESS \_\_\_\_\_  
 CITY \_\_\_\_\_ STATE \_\_\_\_\_  
 GIVE ZIP CODE \_\_\_\_\_

If you have a friend interested in electronics send his name and address for a **FREE** subscription also.

**OLSON ELECTRONICS, INC.**

770 S. Forge Street Akron, Ohio 44308

Circle 123 on reader's service card

# NOTEWORTHY CIRCUITS

## ELECTROLYTIC AC CAPACITORS

Occasionally an industrial electronic technician has to find a temporary substitute for a defective large-value ac capacitor. The old trick of replacing it with two capacitors of double the capacitance, back to back, is well known. Unfortunately, large-capacitance high-voltage electrolytics are not easily obtainable. In some instances the technician would have to parallel two capacitors to get the needed value, and thus would find himself using four capacitors to replace one.

The problem is solved in a neater way with isolating diodes. Their current rating should be at least equal to the peak ac. On the half-cycle when the upper electrode of the top capacitor in the drawing is positive, current flow (conventional) is as shown. The reverse is true, of course, on the next half-cycle.

Another advantage of this hookup is that the reverse voltage across each

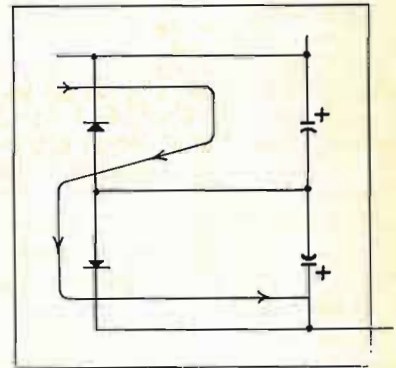

capacitor is limited to the forward voltage drop across its associated capacitor. Thus there is no reverse current. And, of course, the capacitors can be the same size as the one to be replaced.

In one instance, this circuit was used to replace a defective 150 $\mu$ f, 330-Vac capacitor in a Xenon arc-lamp power supply with two 150- $\mu$ f, 450-Vdc capacitors and two 1N3254 diodes.

—R. W. Neale

R-E

## U.S. GOV'T ELECTRONIC SURPLUS

Nationally Known—World Famous SURPLUS CENTER offers finest, most extensive, Government Surplus electronic units and components at a fraction of their original acquisition cost.

ORDER DIRECT FROM AD or WRITE FOR CATALOGS

### STANDARD DIAL TELEPHONE

(ITEM #715) -- Standard, commercial telephone—same as used throughout U.S.A. Attractive polished black, like new condition. Use as extension phone to private systems or connect several phones together for local intercom system. Full instructions are furnished. Wt. 9 lbs. Original Cost \$24.50. **F.O.B. \$5.95**



### STEP-BY-STEP AUTOMATIC SWITCH

(ITEM #738) -- Amazing "up-and-around" electro-magnetic telephone switch. Dial any bank pair from 1 to 100. Make your own telephone system. Can also be used to remotely control up to 100 circuits over a single pair of wires.

One of our FOUR STAR bargains. Comes complete with data, one dial and one line bank. Size, 3" x 7" x 13". Wt. 10 lbs. Cost Gov't Over \$75.00. Complete. Switch, cover, dial, line bank, instructions..... **F.O.B. \$9.95**



### TYPICAL BUYS FROM OUR 1967 CATALOGS

- \$ 350.00 - Geared 2-hp Battery Golf Car Motor ..... **\$24.95**
- \$ 15.00 - Westinghouse DC Ammeter, 0 to 300 ..... **\$ 7.11**
- \$ 40.00 - Vacuum/Pressure Pump, 12-VDC ..... **\$11.95**
- - - 80-MW Walkie-Talkies, Per Pair ..... **\$19.60**
- - - Deluxe, Multi-Range, AC/DC Tester ..... **\$ 8.98**
- \$4000.00 - Carrier Telephone Amplifier System ..... **\$13.91**

### SPECIAL SALE

Correspondence Course In **ELECTRICAL ENGINEERING**

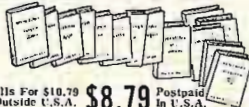

Sells For \$10.79 Outside U.S.A. **\$8.79** Postpaid In U.S.A.

(ITEM #A181) -- Wonderful chance to obtain technical training at Amazing Low Cost! Lincoln Engineering School has suspended its Correspondence Courses because of increased operating costs. We offer a limited number of the school's complete Electrical Engineering Course but without the examination paper grading service. The course consists of 14 lesson unit books. Each book has the regular exams, and in a separate section, "Standard Answers" to each exam question.

Course is well written, easy to understand, profusely illustrated. Reader's Digest size, easy to carry and study in spare time. Many Lincoln Engineering School students holding excellent jobs as a result of L.E.S. training. Course contains latest information on transistors, silicon diodes, etc. Additional book on how to build and operate a "Home Laboratory and Experimental Bench" furnished with each course.

SEND 25c COIN OR STAMPS FOR 3 MAIN CATALOGS

All Items FOB Lincoln Money Back Guaranteed

**SURPLUS CENTER**

DEPT. RE-127 LINCOLN, NEBR. 68501

Circle 124 on reader's service card



"It's a vibrator . . . I got tired of kicking it."

# TRY THIS ONE

ELECTRICAL TAPE SOFTENS

WISE JAWS

Don't let the hard, coarse jaws of your vise mar the finish on a new chassis or panel. Instead, wrap several turns of electrical or plastic tape around the jaws before clamping the work in place. The number of turns is determined by how tight the chassis will be clamped—more protection is needed for tighter clamp-



ing. The tape is easily removed and discarded after the job is finished.

—Robert E. Kelland

R-E

## NAVY MARINE BAND WALKIE TALKIE

**TRANS. & RECEIVER**—Crystal controlled, can be operated on any one channel in freq. range 2.3 to 4.5 MC. Voice (A3) communication only; output of Trans. is 0.2 watts & satisfactory communication between units should be maintained up to approx. one (1) mile. With tubes: 1/1S5, 1/1R5, 2/1T4, 3/3S4. Voltages required: 67.5 VDC 3 MA; 135 VDC 4 MA; 1.5 VDC 225 MA for REC. —67.5 VDC 1.5 MA; 135 VDC 19 MA; 1.5 VDC 225 MA; & -6 VDC 30 MA for T1ANS. Waterproof plastic case w/space for batt. or power supply. Telescoping antenna 8 ft. has special loading coil. Complete w/tubes, antenna, 2 crystals FT-243 (no choice of freq.) headphones, carbon mic., canvas cover, & manual. Size: 8 x 8 x 2 1/2"; Wt.: 8 lbs. **\$9.95**

**"DAV" MODEL**—Same as above, but with direction finding loop circuit for homing; & lip. mic. Ply-wood case w/ carrying straps. Wt.: 11 lbs. **\$12.95**

Dry Charge Battery N-T-8 1/2/abov. Pow. Sup. \$3.95  
Vibrator Power Supply f/MAB & DAV—New \$6.95  
Prices F.O.B. Lima, O. —25% Deposit on COD's—**81¢ FREE CATALOG**—Send for your copy now. Dept. RE

**FAIR RADIO SALES**

1016 E. EUREKA • Box 1105 • LIMA, OHIO • 45802

STATEMENT OF OWNERSHIP, MANAGEMENT AND CIRCULATION. (Act of October 23, 1962, Section 4369, Title 39, United States Code.)

1. Date of filing: October 1, 1967.
2. Title of publication: RADIO-ELECTRONICS.
3. Frequency of issue: Monthly.
4. Location of known office of publication: Ferry Street, Concord, Merrimack County, New Hampshire 03302.
5. Location of the headquarters or general business offices of the publishers: 154 West 14 Street, New York, New York 10011.
6. Names and addresses of publisher, editor, and managing editor: Publisher, M. Harvey Gernsback, 154 West 14 Street, New York, New York 10011; Editor, Robert Cornell, 154 West 14 Street, New York, New York 10011; Managing Editor, Thomas R. Haskett, 154 West 14 Street, New York, New York 10011.
7. Owner: Gernsback Publications, Inc., 154 West 15 Street, New York, New York 10011; M. Harvey Gernsback, 154 West 14 Street, New York, New York 10011; Mary H. Gernsback, M. Harvey Gernsback, Maurice Coyne, Benjamin E. Winston As Trustees Under Trust Agreement dated September 30, 1965 c/o Benjamin E. Winston, Esq., 330 Madison Avenue, New York, New York 10017.

8. Known bondholders, mortgagees, and other security holders owning or holding 1 percent or more of total amount of bonds, mortgages or other securities: None.

9. For completion by nonprofit organizations authorized to mail at special rates: Does not apply in this case.

10. Extent and nature of circulation. The average number of copies each issue during preceding 12 months are: (A) Total number copies printed (net press run): 223,037; (B) Paid circulation: (1) Sales through dealers and carriers, street vendors and counter sales: 46,074; (2) Mail subscriptions: 110,011; (C) Total paid circulation: 156,085; (D) Free distribution (including samples) by mail, carrier or other means: 2,416; (E) Total distribution: 158,501; (F) Office use, left-over, unaccounted, spoiled after printing: 64,536; (G) Total: 223,037. The number of copies single issue nearest to filing date are: (A) Total number copies printed (net press run): 216,677; (B) Paid circulation: (1) Sales through dealers and carriers, street vendors and counter sales: 47,789; (2) Mail subscriptions: 108,405; (C) Total paid circulation: 156,194; (D) Free distribution (including samples) by mail, carrier or other means: 2,187; (E) Total distribution: 158,381; (F) Office use, left-over, unaccounted, spoiled after printing: 58,296; (G) Total: 216,677.

I certify that the statements made by me above are correct and complete.

(Signed) M. Harvey Gernsback  
Publisher

# SCHOOL DIRECTORY

## GET INTO ELECTRONICS

V.T.I. training leads to success as technicians, field engineers, specialists in communications, guided missiles, computers, radar and automation. Basic & advanced courses in theory & laboratory. Electronic Engineering Technology and Electronic Technology curricula both available. Assoc. degree in 29 mos. B.S. also obtainable. G.I. approved. Graduates in all branches of electronics with major companies. Start Feb., Sept. Dorms. campus. High school graduate or equivalent. Catalog.

VALPARAISO TECHNICAL INSTITUTE  
Dept. C, Valparaiso, Indiana 46383



## Learn Electronics for your SPACE-AGE EDUCATION at the center of America's aerospace industry

No matter what your aerospace goal, you can get your training at Northrop Tech, in sunny Southern California.

**COLLEGE OF ENGINEERING.** Get your B.S. degree in engineering in just 36 months by attending classes year round. Most Northrop Tech graduates have a job waiting for them the day they're graduated!

**A & P SCHOOL.** Practical experience on real aircraft. One-year course prepares you for F.A.A. A & P certificate. **WRITE TODAY FOR CATALOG.**

**NORTHROP INSTITUTE OF TECHNOLOGY**  
1199 W. Arbor Vitae, Inglewood, Calif.



## ENGINEERING MATHEMATICS

**NOW! A NEW WAY TO LEARN**—I. H. S. I. WAY. A complete home study course in engineering math to help you get the position you want—**MORE MONEY—MORE RESPECT.** **COURSE PREPARED BY COLLEGE PROFESSORS**

who have lectured to thousands of men on math and engineering. You learn at home quickly, easily—**AS FAST** as you want.

**YOU SIGN NO CONTRACTS**

Pay only if satisfied—you owe it to yourself to examine the **INDIANA HOME STUDY INSTITUTE COURSE IN ENGINEERING MATH.**

**FREE BONUS**—if you join now, a refresher course in basic arithmetic.

Write for Brochure—No Obligation.

**THE INDIANA HOME STUDY INSTITUTE**  
Dept. RE-12, P.O. Box 1189  
Panama City, Fla. 32401

## for a professional career

Tri-State graduates hold important engineering and business administration posts throughout the U. S. This professionally-oriented small college has outstanding placement record. Four-quarter year permits degree in three years. Excellent faculty. Well-equipped labs. Beautiful 300-acre campus. Accredited. Small classes. Modest costs. One-year Drafting-Design Certificate program. Enter Jan., March, June, Sept. For Catalog, write Director Admissions. Approved for veterans.



**TRI-STATE COLLEGE**

24127 College Avenue, Angola, Indiana 46703

## Prepare today . . . for an ELECTRONICS CAREER

- Radio Broadcasting
- Television
- Computers • Radar
- Industrial Electronics
- Transistors • Transmitters
- Microwave Techniques

Free Catalog

No Salesman Will Call

Tuition Weekly

No Down Payment

VETERAN APPROVED

## PHILADELPHIA WIRELESS TECHNICAL INSTITUTE

1533 PINE STREET

PHILADELPHIA, PA. KI 6-0745

Circle 125 on reader's service card

# MARKET CENTER

## GENERAL

CONVERT ANY TELEVISION to sensitive Big-Screen Oscilloscope. Only minor changes required. No electronic experience necessary. Illustrated plans \$2.00. RELCO-A25, Box 10563, Houston 18, Texas

TV SERVICE ORDER BOOKS for use with your rubber stamp. Duplicate or triplicate. Low cost. Write for FREE 32 PAGE CATALOG and Special Rubber Stamp Offer. OELRIC PUBLICATIONS, 6556 W. Higgins, Chicago, Ill. 60656

FREE ELECTRONICS (new and surplus) Parts catalog. We repair multimeters. BIGELOW ELECTRONICS, Bluffton, Ohio 45817

## ARCTURUS INVENTORY REDUCTION SALE

• Tube Bargains. to name just a few: #6939, \$3.50; #6360, \$3.50; #6688, \$3.50; #5842/417A, \$2.50; #5847/ #404A, \$2.50; #2D21, 49¢; #6146, \$2.95; #7025, 59¢; #616, 49¢; #6K7, 39¢ each, 3 for \$1; #UX200, \$1.69; #1AX2, 49¢ each; 5 for \$2; #12BN6, 39¢ each, 3 for \$1; #25L6, 59¢ each, 3 for \$1.49; #6CG7, 59¢; #6BQ7, 94¢; 6A5, 56¢; #6U8, 77¢; #6T8, 84¢.

• Tube Cartons: 6AU6 etc. size, \$1.75 per 100. 6SN7 etc. size, \$2.10 per 100. 5U4GB size, \$2.50 per 100. 5U4G size, 03¢ each.

• Kit of 15 sub-miniature Tubes made by Sonotone for Walkie-Talkie etc. use, Cat. #29, 99¢ per kit.

• 7 Inch 90 degree T.V. bench test picture tube with adapter. No Ion trap needed. Cat. #7BP7, \$6.99.

• Silicon Rectifier octal-based long-life replacement for 5U4, 5Y3, 5AS4, 5AW4, 5T4, 5V4, 5Z4. With diagram. Cat. #Rect 1, 99¢ each.

• OZ4 Silicon Rectifier replacement, octal based. Cat. #Rect. 2, 99¢ each.

• 10 Flangeless Rectifiers, 1 amp, 400 to 1000 p.i.v. Cat. #RS10, \$2.98.

• 10 Silicon Rectifiers, 750 MA., 50 to 300 p.i.v. Cat. #330F, 99¢.

• 12 Zener Diodes, amperages from 250 mw to 1 watt, voltages 2.7 to 40, each value marked. Axial and stud types. Cat. #ZD12, \$1.98.

• 2 Silicon controlled Rectifiers, 1 amp, general purpose units with instructions. Cat. #SCR1, \$1.00.

• 5 Transistor Circuit Boards containing up to 6 transistors, plus diodes, resistors, capacitors, etc. Cat. #TB10, 99¢.

• Color Yokes, 70 degree for all round color CRT's. Cat. #XRC70, \$12.95. 90 degree for all rectangular 19 to 25 inch color CRT's. Cat. #XRC90, \$12.95.

• Transistorized U.H.F. Tuners used in 1965 to 1967 TV sets made by Admiral, RCA, Motorola, etc. Removable gearing may vary from one make to another. Need only 15 volts d.c. to function. No filament voltage needed. Easy replacement units. Cat. #U.H.F. 567, \$4.95.

• General Electric U.H.F. miniature transistorized Tuner, G.E. Part #ET85X-83. Cat. #GE85, \$4.95.

• F.M. Tuner, Hi-Fi amplifier tuning unit complete with diagram, 2 tubes. Sam's Photofacts #620 lists 2 applications. Cat. #FM20, \$3.98.

• Flyback Transformer, in original cartons, made by Merit or Todd. Most with schematic drawing of unit. Please do not request specific type. Cat. #506, 99¢.

• Flyback Transformer Kits, 2 flybacks per kit. #502E, Emerson; #502Y, Silvertone; #502W, Westinghouse; #507, Philco; #502, RCA. Any kit \$2.99.

• Kit of 30 tested Germanium Diodes. Cat. #100, 99¢.

• Kit of 10 NPN Transistors. Cat. #371, 99¢. 10 PNP Transistors. Cat. #370, 99¢. All tested.

Send for our FREE CATALOG listing thousands of similar best buys in tubes, parts, kits, transistors, rectifiers, etc. Orders under \$5.00, add 50¢ handling charge. Include 4% of dollar value of order for postage.

## ARCTURUS ELECTRONICS CORP.

502-22nd St., Union City, N.J. 07087 Dept. MRE

Circle 141 on reader's service card

TREASURE HUNTERS! PROSPECTORS! Relco's new instruments detect buried gold, silver, coins. Kits, assembled models. Transistorized. Weighs 3 pounds, \$19.95 up. Free catalog. RELCO-A25, Box 10839, Houston, Texas 77018

BACK-ISSUES, Electronic, Scientific Magazines. SEMCO, Box 130, Roxboro, Quebec, Canada

SAMS PHOTOFACT FOLDERS 1-150, fifteen binders, (few pages missing), \$502.50 value, only \$95. Extra blank binders, \$1.50 each. Old Rider Manuals, \$3 each. 100 different radio magazines, \$15. Fifty pounds radio-television diagrams, \$20. Shipped freight collect. HARTFORD, 1760 Balsam Road, Highland Park, Ill. 60035

MAGNETS, ALL TYPES. Specials—20 disc magnets, or 2 stick magnets, or 10 small bar magnets, or 8 assorted magnets, \$1.00. MARYLAND MAGNET COMPANY, 5412-G Gist, Baltimore, Maryland 21215

## TRANSISTOR BOARDS

#103 2EA 2N706, 6EA IN917 ... 6 Boards \$3.00  
 #101 6EA 2N711 ... 2 Boards \$3.00  
 #301 3EA 2N1411 ... 4 Boards \$3.00  
 Above, new, minimum salvageable lead length ½ in.

Audio Tape, ¼ in. 1½ mil, approx. 4000 ft., 2 reels \$7.50 Shipped Prepaid Continental U.S.A.

LEED'S RADIO, 57 WARREN ST., N.Y.C. 10007  
 Tel: (212)-267-3440

## "TAB" • SILICON ONE-AMP DIODES

Full Leads Factory Tested & Gtd U.S.A. Mfg

Piv/Rms	Piv/Rms	Piv/Rms	Piv/Rms
50/35	100/70	200/140	300/210
.05	.07	.10	.12
400/280	600/420	800/560	900/630
.14	.21	.30	.40
1000/700	1100/770	1700/1000	2400/1680
		1.00	1.75

## SCR-SILICON-CONTROL-RECTIFIERS!!!

PRV	7A	25A	PRV	7A	25A
50	.45	.75	500	2.50	3.00
100	.65	1.15	600	2.75	3.50
200	1.00	1.60	700	3.00	4.00
300	1.50	2.00	800	3.60	4.75
400	2.00	2.50	900	4.30	5.50

## SILICON POWER DIODES & STUDD

D.C. Amps	50 Piv	100 Piv	200 Piv	600 Piv
15	35 Rms	70 Rms	140 Rms	420 Rms
45	.75	.85	1.15	1.85
160	2.50	2.65	3.50	6.50
250	3.25	4.50	6.00	12.25

## "TAB" TERMS: Money Back Guarantee

Our 2212 Year A.M. Shipping Charges  
 111 GX LIBERTY ST., N.Y., N.Y. 10006  
 Send 25¢ Phone REctor 2-6245 for Catalog

## LIKE MUSIC WITHOUT COMMERCIALS?

67K HZ FM SUB-CARRIER ADAPTER (COMPLETELY WIRED) SMALL SCA-2 FOR ONLY \$34.95

UNIT REQUIRING NO FIELD ADJUSTMENT. Available in General Electric Model T2230 table radio. This is an AC operated, 13 transistor, AM/FM radio with a four inch speaker, for \$49.95. Send order to: KENZAC, P.O.B. 66251, Houston, Tex. 77006.

The SCA-2 sub-carrier adapter makes it possible for you to enjoy the background music transmitted on a 67KHz sub-carrier on many FM stations. (These programs cannot be heard on a FM set without an adapter) In the US there are approximately 400 FM stations authorized by the FCC to transmit the 67KHz programs. If you are within 50 miles of a city of 100,000 or more, it is probable that you are within the satisfactory reception range of one or more of these stations. If in doubt write for a list of such stations in your area.

Only four connections to your FM receiver or FM tuner/amplifier. These are: Multiplex output, audio input, and DC power. If your FM set does not have a multiplex output jack, we supply instructions of where to connect.

ONE YEAR FACTORY GUARANTEE

THE SCA-2 IS A STABLE, EXTREMELY LOW NOISE UNIT REQUIRING NO FIELD ADJUSTMENT.

Available in General Electric Model T2230 table radio. This is an AC operated, 13 transistor, AM/FM radio with a four inch speaker, for \$49.95. Send order to: KENZAC, P.O.B. 66251, Houston, Tex. 77006.

# ADVERTISING INDEX

RADIO-ELECTRONICS does not assume responsibility for any errors which may appear in the index below.

Allied Radio Corp. ....	76
Arcturus Electronics Corp. ....	94
Artisan Organs ....	80
Brooks Radio & TV Corp. ....	88-89
Burstein-Applebee Co. ....	86
Capitol Radio Engineering Institute, The ...	18-21
Castle TV Tuner Service, Inc. ....	91
<b>CLASSIFIED</b> ...	94-97
Cleveland Institute of Electronics ...	5, 63-64
Cook's Institute of Electronics Engineering ...	62
Cornell Electronics Co. ....	96
Delta Products, Inc. ....	60
DeVry Institute of Technology (A Subsidiary of Bell & Howell) ....	7
Edmund Scientific Co. ....	95
EICO Electronic Instrument Co., Inc. Third Cover Electro-Voice, Inc. ....	61
Electronic Measurement Corp. (EMC) ....	76
Fair Radio Sales ...	93
Finney Co. ....	15
GC Electronics Company ....	65
General Electric ...	12
Grantham School of Electronics ...	1
Heald Colleges ...	91
Heath Company ...	68-69
Injectorall Electronics Corp. ....	22
International Crystal Mfg. Co., Inc. ....	98
Jerrold Electronics Corporation (Distributor Sales Division) ...	71
JFD Electronics Co. ....	2
Mallory Distributor Products Company (Div. of P. R. Mallory & Co., Inc.) ...	17
Microflame, Inc. ....	67
Mike Quinn Electronics ...	97
Multicore Sales Corp. ....	91
Music Associated ...	79
National Radio Institute ...	8-11
National Technical Schools ...	13
Nova-Tech, Inc. ....	79
Olson Electronics, Inc. ....	92
Oxford Transducer Company (A Division of Oxford Electric Corporation) ...	80
Philadelphia Wireless Technical Institute ...	93
Poly Paks ...	97
Quam-Nichols Company ...	6
RCA Electronic Components and Devices Semiconductors ...	66
Test Equipment ...	81
Tubes ...	Fourth Cover
RCA Institutes ...	28-31
Reading Improvement Program ...	89
Round Hill Associates Inc. (A Milo Electronics Subsidiary) ...	26
Rye Industries, Inc. ....	67
Salch & Co., Herbert (Marketing Division of Tompkins Radio Products) ...	80
Sams & Co., Inc., Howard W. ....	14
Schober Organ Corp., Inc. ....	4
Scott, Inc., H. H. ....	22
Semiconitors Corp. ....	76
Score ...	70, 87
Sentry Manufacturing Company ...	27
Shure Bros. ....	75, 77, 79
Solid State Sales ...	95
Sonotone Corp. (Electronic Applications Div.)	88
Sony Corp. of America ...	4
Sony/Superscope ...	16
Sprague Products Company ...	78
Surplus Center ...	92
Sylvania (Subsidiary of General Telephone & Electronics) ...	23
TAB Books ...	90
Tram Corporation ...	71
Triplet Electrical Instrument Company ...	Second Cover
Warren Electronic Components ...	96
Weller Electric Corp. ....	62
Winegard Co. ....	24-25
Xcelite, Inc. ....	14
<b>MARKET CENTER</b> ...	94-97
Edmund Scientific Co. Kenzac Leed's Radio McGee Radio Spectrum Products Corp. Sydnam Electronics Specialties TAB	
<b>SCHOOL DIRECTORY</b> ...	93
Indiana Home Study Institute, The Northrop College of Science & Engineering Tri-State College Valparaiso Technical Institute	

BURGLAR, Fire Alarm supplies and information. Send \$1.00 (refundable) for catalog to PROTECTO ALARM SALES, Box 357 Birch Run, Michigan 48415

POPULAR ELECTRONICS complete file. Slip cased, mint condition. Make offer. BILL DODSON, 210 Arterburn, Lyndon, Ky. 40222

## WANTED

QUICK CASH . . . for Electronic EQUIPMENT, COMPONENTS, unused TUBES. Send list now! BARRY, 512 Broadway, New York, N.Y. 10012, 212 WALKER 5-7000

Wanted, HEATHKIT Q-METER, HAROLD MURRAY, Box 74, Neffsville, Pa. 17556

## ELECTRONICS

BARGAINS in Canadian Electronic equipment and surplus. Send \$1.00 for giant catalogs. ETCO, Box 741, Dept. R, Montreal, Canada

TUBES. "Oldies", latest. Lists free. STEINMETZ, 7519 Maplewood, Hammond, Indiana 46324

RECEIVING & INDUSTRIAL TUBES, TRANSISTORS, All Brands—Biggest Discounts. Technicians, Hobbyists, Experimenters—Request FREE Giant Catalog and SAVE! ZALYTRON, 469 Jericho Turnpike, Mineola, N.Y. 11501

Discharge IGNITION, PHOTOFLASH. Free catalog parts, kits. TRANSPARK, Carlisle, Mass. 01741

RADIO & TV TUBES 33¢ each. One year guaranteed. Plus many unusual electronic bargains. Free catalog. CORNELL, 4217-E University, San Diego, California 92105

MESHNA'S TRANSISTORIZED CONVERTER KIT Converts car radio to receive police & fire. 35-50Mc or 100-200Mc. (one Mc tuning) with simple step instructions \$5.00. MESHNA, No. Reading, Mass. 01864

TV CAMERAS: Assembled and kits. Also plans, vidicons, lenses, scan coils, etc. NEW catalog 10¢. ATV RESEARCH, Box 453, Dakota City, Nebr. 68731

GIANT JAPANESE ELECTRONICS CATALOG. \$1. DEE, 10639A Riverside, North Hollywood, Calif. 91602

BRAND NEW TUBES. World's lowest prices on Radio, TV-industrial-special purpose tubes. Write for free parts catalog. UNITED RADIO CO., Newark, N.J. 07101

UNUSUAL solid-State kits. Amplifiers, mikes, power units, controls. Amazingly low-priced quality products. Free brochure. COSMOSE ENTERPRISES, 507 Fifth Avenue, New York, N.Y. 10017

"COIL WINDING" Handbook—50¢. Experimenter's catalog includes 250 exclusive items—25¢, refundable. LABORATORIES, 12041-B Sheridan, Garden Grove, Calif. \$2640

## AUDIO — HI-FI

RENT STEREO TAPES—over 2,500 different—all major labels — free brochure. STEREO-PARTI, 1616-R Terrace Way, Santa Rosa, Calif. 95404

WRITE for highest discounts on components, recorders, tapes, from franchised distributors. Send for FREE monthly specials. CARSTON, 1686-R Second Ave. N.Y.C. 10028

HI-FI COMPONENTS, Tape Recorders, at guaranteed "WE will not be undersold" prices. 15-day moneyback guarantee. Two-year warranty. NO Catalog. Quotations Free. HI-FIDELITY CENTER, 239R East 149th St., N.Y., N.Y. 10451

TAPE RECORDER SALE. Brand new, latest models, \$10.00 above cost. ARKAY SALES, 1028-E Commonwealth Ave., Boston, Mass. 02215

TAPEMATES makes available to you ALL 4-TRACK STEREO TAPES—ALL LABELS—post-paid to your door—at tremendous savings. For free brochure write TAPEMATES CLUB, 5727 W. Jefferson Blvd., Los Angeles, Calif. 90016

INSTALLERS! HAMMOND Reverberation mechanism—\$4. CAL'S, Box 234, Dearborn, Michigan 48121

STEREO TAPES, Save 30% and up; no membership or fees required; postpaid anywhere USA. FREE 70-page catalog. We discount batteries, recorders, tape/accessories. Beware of slogans, "not undersold", as the discount information you supply our competitor is invariably reported to the factory. SAXITONE, 1776 Columbia Road, N.W., Washington, D.C. 20009

AMPEX VR7000 VTR with 1" tape. Portable case. Used 400 hours. New price \$3400. Selling for \$2800. MARTIN SHALEK, 87 Fairmont St., Malden, Mass. 02148 (617) 324-2411

OLD RADIO PROGRAMS ON TAPE. Inner Sanctum, Suspense, Jack Armstrong, Gangbusters, Sam Spade, hundreds more. Sample reel \$5.00. Hobby Magazine for collectors of old radio tapes, old comics and strips, pulp mags, etc., \$1.00 or sent free with tape order. NOSTALGIC HOBBIES, Dept. R.E., 9875 SW 212 St., Miami, Fla. 33157

## INVENTIONS & PATENTS

INVENTIONS-IDEAS developed: Cash/Royalty sales. Member: UNITED STATES CHAMBER COMMERCE, Raymond Lee, 230-U Park Avenue, New York City 10017

WE WANT YOU TO MAKE

THE SWITCH.

JOIN OUR GROWING LIST

OF THOUSANDS OF

SATISFIED CUSTOMERS

Our semiconductors have full factory length leads, are American made, unused, and in good physical condition. Our technical descriptions and pictures are accurate.

### ZENERS

1 Watt 6-33V	\$ .50
10 Watt 6-200V	\$ .75
50 Watt 6-200V	\$ 1.75

### 1 AMP

Top Hat & Epoxy

PRV	AMP
100	.07
200	.09
400	.12
600	.18
800	.22

PRV	AMP
1000	.35
1200	.50
1400	.65
1600	.80
1800	.90

## TRIACS

TO-66  
5 AMPS

PRV
100
200
300
400
500

SIM TO 2N3429 (NPN)  $S1, \frac{1}{2}''$  stud, min Hfe of 30, 7.5 amps, 175 watts, Vce of 75. \$2.75

SILICON BILATERAL SWITCH. Replaces two SCR's by firing in either direction when breakdown voltage is exceeded. Used in light dimmers, etc. . . . .2/\$1.00

1000 PRV at 3A full wave bridge . . . . . \$3.50

NEON LIGHT OF NIXIE TUBE DRIVERS. An NPN, TO-18, Si Transistor with a V<sub>CB0</sub> of 120 3/\$1.00

500 Hfe PLASTIC TRANSISTORS (NPN) TO-18, S1 unit sim to 2N3565. 3/\$1.00

SIM. to 2N2875 (PNP). Silicon 20 watts with 30 MHz cut off \$ .75

HIGH-VOLTAGE NPN 150V VCB0 at 2.5A, hi gain in TO-66 pack . . . . . \$ .75

### Silicon Power Rectifiers

PRV	3A	12A	20A	40A
100	.09	.30	.40	.75
200	.16	.50	.60	1.25
400	.20	.70	.80	1.50
600	.30	1.00	1.20	1.80
800	.40	1.25	1.50	2.30
1000	.55	1.50	1.80	2.70

## MORE INTEGRATED CIRCUITS



- SR FLIP FLOPS . . . . . \$ .90
- JK FLIP FLOPS . . . . . \$1.15
- DUAL NAND NOR GATES . . . \$1.00
- SR CLOCKED FLIP FLOPS . . . \$1.15
- SRT FLIP FLOPS . . . . . \$1.15
- 8 INPUT NAND NOR GATES . . \$1.00
- DUAL AND GATE . . . . . \$1.00
- QUAD NAND NOR GATES . . \$1.00

TO-85 flat pack with holder. Guaranteed to work. They come complete with schematic, elect. characteristic sheet and some typical applications.

CADMIUM SELENIDE PHOTO CONDUCTIVE CELLS. Dark resistance of 500 megohms. Sensitivity of 1-4.99  $\mu\text{A}/\text{ft candle}$  \$1.25

### Silicon Control Rectifiers TO-66 pack Studs

PRV	3A	7A	20A
50	.35	.45	.70
100	.50	.65	1.00
200	.70	.95	1.30
300	.90	1.25	1.70
400	1.20	1.60	2.10
500	1.50	2.00	2.50
600	1.80	2.40	
700	2.20	2.80	
1000		4.00	

Terms: FOB Cambridge, Mass. Send check or Money Order. Rate companies 30 days net. Include Postage, Average Wt. per package 1/2 lb. Allow for C.O.D. Minimum Order \$3.00

## UNUSUAL BARGAINS

EXCELLENT XMAS GIFTS!

### GIANT WEATHER BALLOONS



"Balls of fun" for kids, traffic stoppers for stores, terrific for amateur meteorologists. Create a neighborhood sensation. Great backyard fun. Exciting beach attraction. Made of heavy duty neoprene. Inflate with vacuum cleaner or auto air hose; or locally available helium for high rise.

- Stock No. 60,568EH . . . . . (8' diam.) . . . . . \$2.00 Ppd.
- Stock No. 60,632EH . . . . . (16' diam.) . . . . . \$7.00 Ppd.

### NICKEL-CADMIUM BATTERY BARGAINS

Terrific value—used government surplus. Quick-charge, lightweight 6-volt nickel-cadmium battery. 4-amp. hour capacity. Almost unlimited life—thousands of discharge-charge cycles with minute deterioration. Charges fully in approx. 1 hr. with Edmund Charger Kit. Hundreds of uses for hobby, photography, model building, industry, etc. Only few drops of water yearly for full maintenance. Recharge minimum of electrolyte-sealed to prevent loss. Delivers nearly 100% output at below freezing. Maintains constant voltage through major portion of capacity. Five vented 1.2 volt cells strapped in 3 polypropylene bands. 3 1/2"x2"x6", 10 & "Jumbo" 275 Ampere Hour Batteries also available. Write for info.



- Stock No. 70,942EH . . . . . \$15.00 Ppd.
- ONE NEW 1.2 VOLT NICKEL-CADMIUM CELL
- Stock No. 40,798EH . . . . . \$ 3.95 Ppd.
- CHARGER KIT FOR 6-VOLT BATTERY
- Stock No. 70,807EH . . . . . \$ 8.00 Ppd.

Order by Stock No. Check or M. O.—Money-Back Guarantee.

**EDMUND SCIENTIFIC CO.** 300 EDCORP BLDG., BARRINGTON, N.J. 08007

## CLIP AND MAIL COUPON TODAY

SEND FOR FREE CATALOG "EH"

EDMUND SCIENTIFIC CO. 300 EDCORP BUILDING BARRINGTON, N.J. 08007

Completely new 1968 edition. New items, categories, illustrations, dozens of electrical and electromagnetic parts, accessories. Enormous selection of Astronomical Telescopes, Microscopes, Binoculars, Magnifiers, Magnets, Lenses, Prisms. Many war surplus items: for hobbyists, experimenters, workshop, factory. Mail coupon for catalog "EH".



NAME . . . . .  
ADDRESS . . . . .  
CITY . . . STATE . . . ZIP . . .

Circle 142 on reader's service card

## SILICON RECTIFIER SALE

IMMEDIATE DELIVERY  
FULLY GTD AMERICAN MADE  NEWEST TYPE FULLY TESTED

1 AMP SILICON "TOPHAT" & EPOXY DIODES  
LOW LEAKAGE FULL LEAD LENGTH

PIV/RMS	PIV/RMS	PIV/RMS	PIV/RMS
50/35 .05 ea.	100/70 .07 ea.	200/140 .10 ea.	300/210 .12 ea.
PIV/RMS 400/280 .14 ea.	PIV/RMS 500/350 .19 ea.	PIV/RMS 600/420 .21 ea.	PIV/RMS 700/490 .23 ea.
PIV/RMS 800/560 .25 ea.	PIV/RMS 900/630 .30 ea.	PIV/RMS 1000/700 .40 ea.	PIV/RMS 1300/970 .50 ea.

ALL TESTS AC & DC & FWD & LOAD  
SILICON POWER DIODE STUDS

D.C. AMPS	50 PIV 35 RMS	100 PIV 70 RMS	150 PIV 105 RMS	200 PIV 140 RMS
3	.08 ea.	.12 ea.	.16 ea.	.22 ea.
12	.25	.50	.65	.75
35	.65	.90	1.25	1.40
100	1.50	2.00	1.50	3.00
160	2.50	3.00		3.75

D.C. AMPS	300 PIV 210 RMS	400 PIV 280 RMS	500 PIV 350 RMS	600 PIV 450 RMS
3	.27 ea.	.29 ea.	.37 ea.	.45 ea.
12	.90	1.30	1.40	1.65
35	2.00	2.35	2.60	3.00
100	2.50	3.50	4.00	5.00
160	4.25	4.75	5.10	Ask

"SCR" SILICON CONTROLLED RECTIFIERS "SCR"

PRV	AMP	AMP	PRV	AMP	AMP
7	.50	.75	1.00	2.50	2.50
25	.60	.90	1.25	3.00	2.40
50	.80	1.25	1.50	4.00	2.75
100	.90	1.60	2.00	6.00	3.25
150	1.25	1.80	2.25	8.00	3.40
200	1.50	2.00	2.50	10.00	4.50

SPECIALS! SPECIALS!

Westinghouse 160 AMP, 500 PIV SILICON HI-POWER STUD RECTIFIER IN1666.  
Limited quantity. \$5.10 ea. 10 for \$45.00

100 Different Precision Resistors  
1/2-1-2 Watt 1/2%-1% TOL \$1.25

Asst transistor Kit. P.N.P.—N.P.N.  
All popular types. Unchecked  
100 for \$2.95 500 for \$9.95

Computer Grade Condenser 15,500 MFD  
12 VDC American Mfg. .75 ea.

Type IN34 DIODE GLASS .07 ea 100 for \$5  
Money Back guarantee. \$2.00 min. order. Include additional \$ for postage. Send check or money order. C.O.D. orders 25% down.

Warren Electronic Components

230 Mercer St., N. Y., N. Y. 10012 • 212 OR 3-2620

Circle 144 on reader's service card

# MARKET CENTER

## BUSINESS AIDS

JUST STARTING IN TV SERVICE? Write for FREE 32 PAGE CATALOG of Service Order books, invoices, job tickets, phone message books, statements and file systems. OELRICH PUBLICATIONS, 6556 W. Higgins, Chicago, Ill. 60656.

1,000 Business Cards, "Raised Letters" \$3.95 postpaid. Samples. ROUTH, 5717 Friendswood, Greensboro, N. C. 27409

TWO-WAY RADIO SERVICE INVOICE FORMS—Detailed. Free Sample Form No. 50 and Catalog. OELRICH PUBLICATIONS, 6554 W. Higgins, Chicago, Ill. 60656

Attention: TV Service Dealers. HIGHLY DETAILED TV SERVICE ORDER FORM STOPS PRICE COMPLAINTS BEFORE THEY START. FREE CATALOG AND SAMPLE NO. 206. OELRICH PUBLICATIONS, 6554 W. Higgins, Chicago, Ill. 60656

Attention: TV Service Dealers. TV SERVICE CONTRACTS FORMS. Free Catalog and Samples No. 105. OELRICH PUBLICATIONS, 6554 W. Higgins, Chicago, Ill. 60656

"PROFIT GUARD" BOOKKEEPING SYSTEM FOR TV SERVICE. Complete—easy to use. Free Catalog and Sample No. 1800 Page. OELRICH PUBLICATIONS, 6554 W. Higgins, Chicago, Ill. 60656

WRITE NOW FOR 1968 SENT FREE

## MCGEE'S CATALOG

1001 BARGAINS IN SPEAKERS—PARTS—TUBES—HIGH FIDELITY COMPONENTS—RECORD CHANGERS—Tape Recorders—Kits—Everything in Electronics  
1901 McGee Street, Kansas City (RE), Missouri 64108



Mod. Size Hwd Net Ea.  
536 2x6.2x5 \$1.89  
538 3x8.2x5 2.19  
Other models available free literature

EQUIPMENT CABINETS  
Modern, deluxe-styled aluminum cabinets, rich leatherette covered top in black or brown with silver grey or gold panel. Rubber feet. At your dealer or order direct from:

SPECTRUM PRODUCTS CORP.  
13946 Blackstone, Detroit, Mich. 48223

## 8 PIECE TOOL KIT

69¢  
-10 Shipping  
contains 4 Bristo Wrenches  
1 Hex Blade  
2 Alignment (tuning) Tools  
in original mfr's bags and boxes

## CORNELL

# 33¢

PER TUBE  
100 TUBES OR MORE:  
30¢ PER TUBE

## TUBES 1 YR. GUARANTEED

Mutual Conductance Lab-tested, Individually Boxed, Branded and Code Dated. Tubes are new, or used and so marked.

OZ4	6A55	6CD6	6K6	6X4	12BF6
1B3	6AT6	6CF6	6K7	6XB	12BH7
1J3/1K3	6AT8	6CG7	6Q7	7A7	12BL6
1H5	6AU4	6CG8	6S4	7A8	12BY7
1L4	6AU5	6CM7	6SA7	7B6	12C5
1T4	6AU6				12CA5
1U4	6AW8				12SN7
1X2	6AX4				12SQ7
3B26	6BA6				25L6
3DG4	6BA7				25Z6
5U4	6BC5				35W4
5U8	6BD6				35Z3
5Y4	6BG6	6CZ5	6SH7	7C5	
5Y3	6BJ6	6D6	6SJ7	7N7	50L6
6A6	6BL7	6DA4	6SK7	7Y4	
6A8	6BN4	6DE6	6SL7	12AD6	24
6AB4	6BN6	6D06	6SN7	12AE6	27
6AC7	6BQ6	6EAT	6SQ7	12AF6	77
6AG5	6BQ7	6EM5	6SR7	12AT7	78
6AK5	6BQ7	6F6	6U7	12AU7	84/6Z4
6AL5	6BZ6	6GH8	6U8	12AX7	5687
6AN8	6C4	6H6	6V6	12BA6	6350
6A05	6C6	6J5	6W4	12BD6	6463
	6CB6	6J6	6W6	12BE6	7044

Other tubes at low prices—send for free list  
NO SUBSTITUTIONS WITHOUT YOUR PERMISSION

INTERFERENCE TV TRAPPER  
SUPPRESS PICTURE INTERFERENCE CAUSED BY:

- AUTO IGNITION
- AIRPLANES
- APPLIANCES
- NEON SIGNS
- OIL BURNERS
- AMATEUR RADIO TRANSMITTERS

\$1.59 + 10c shipping

TV LIFESAVER!  
STOP TUBE BURNOUTS!

\$1.79 + 20c shipping

SILICON RECTIFIERS

all purpose ELECTRONIC CLEANER 89c plus shipping

TUBE CARTONS

SIZE	FOR TUBE SIZE	PRICE PER 10 CARTONS	PRICE PER 100 CARTONS
3 1/2" x 3 1/2" x 4 1/2"	6A55	.39	3.49
3 1/2" x 3 1/2" x 4 1/2"	6AT8	.59	5.29
3 1/2" x 3 1/2" x 4 1/2"	6C4	.89	7.99

11,000 TUBE SUBSTITUTES \$1.25

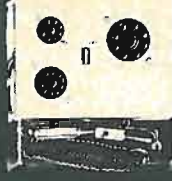

RADIO-TV TUBE TESTER \$2.89 plus 30c shipping

Special! With every \$10 Order  
**25¢** per tube  
(No Limit) from this list.  
6AG5 6SN7  
6AQ5 6CB6 6S4  
6AU6 6J6 6W4

COLOR TV, 395 DEGAUSSER plus 40c shipping

Solder Iron 1.49  
Elect Tape .89  
Epoxy (pr.) .79  
Diode Kit .39  
Noise Filter .89  
Neon Tester .59  
Solder .39  
Antenna Coupler 1.89  
Battery Charger 4.95

Prestige & Success are yours as an ELECTRONIC EXPERT

FOR CORNELL CUSTOMERS ONLY by special arrangement with the publisher, these amazing bargains are available

COMPLETE RADIO SERVICING HND BASIC ELECTRONICS COURSE ONLY \$3.00 (52.50 + 50 postage charges)

NEW PRACTICAL TV TRAINING COURSE ONLY \$3.50 (52.50 + 50 postage charges)

Both above courses \$6.00

## CORNELL ELECTRONICS CO.

Dept RE12 4217 University Ave., San Diego, Calif. 92105

TERMS: Add 3c per tube shipping. Orders under \$5.00 add 3c per tube shipping plus 50c handling. Canadian orders add approximate postage. Send 25% deposit on C.O.D. orders. No C.O.D. orders under \$5.00 or to Canada. No 24 hr. free offer on personal check orders. 5-DAY MONEY BACK OFFER.

SEND FOR FREE CATALOG

Circle 145 on reader's service card





# Meet The Dividers!

## ICD SERIES INTEGRATED CIRCUIT DIVIDERS

They are new from International. Use them for crystal controlled time bases, scope calibrators, and clock sources.

International ICD units are totally integrated circuit frequency dividers. They are smaller than a pack of cigarettes (1" x 2¼" x 2¾"). All have two separate outputs. They are packaged in nine types providing divide ratios 2 thru 10. No tuning or adjustment is required. The output pulse has the same stability as the driving pulse. Voltage required, 3.6 vdc  $\pm$  10%.

### FREQUENCY RANGE

ICD-10 to 10 MHz ..... \$19.95 ea.

ICD-2 thru ICD-9 to  
2 MHz ..... \$19.95 ea.

ICD Buffer (for feeding  
more than one circuit) \$ 9.95 ea.

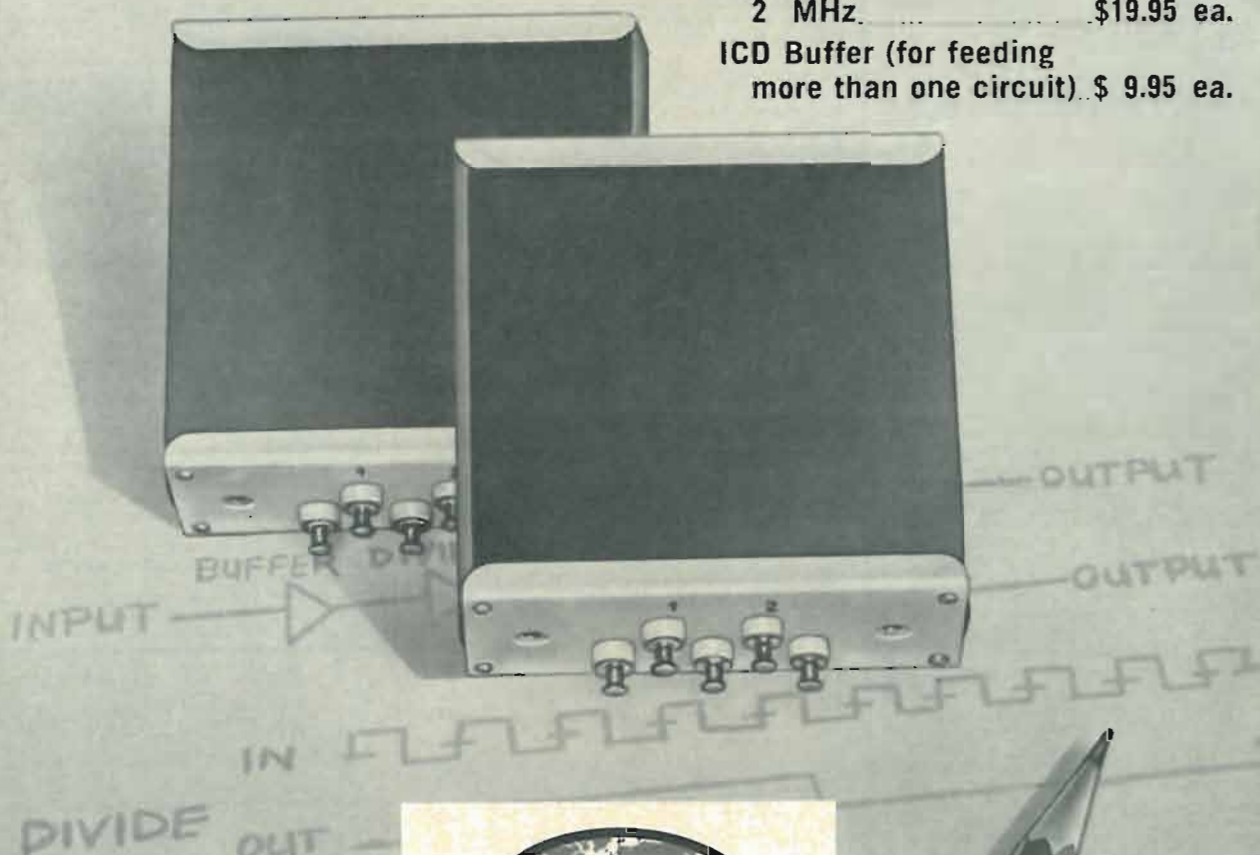

WRITE FOR COMPLETE CATALOG.



**CRYSTAL MFG. CO., INC.**  
10 NO. LEE • OKLA. CITY, OKLA. 73102

Circle 148 on reader's service card

# EICO Makes It Possible

Uncompromising engineering—for value does it!  
You save up to 50% with Eico Kits and Wired Equipment.

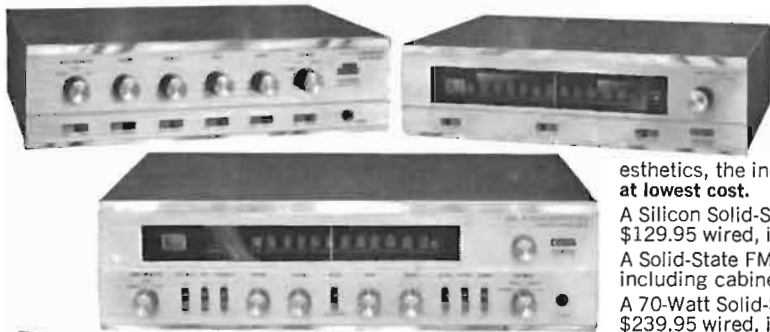

## Cortina Stereo

Engineering excellence, 100% capability, striking esthetics, the industry's only **TOTAL PERFORMANCE STEREO** at lowest cost.

A Silicon Solid-State 70 Watt Stereo Amplifier for \$89.95 kit, \$129.95 wired, including cabinet. Cortina 3070.

A Solid-State FM Stereo Tuner for \$89.95 kit, \$129.95 wired, including cabinet. Cortina 3200.

A 70-Watt Solid-State FM Stereo Receiver for \$159.95 kit, \$239.95 wired, including cabinet. Cortina 3570.



## Eicocraft

The newest excitement in kits. 100% solid-state and professional.

Fun to build and use. Expandable, interconnectable. Great as "jiffy" projects and as introductions to electronics. No technical experience needed. Finest parts, pre-drilled etched printed circuit boards, step-by-step instructions.



Electronic Siren \$4.95, Burglar Alarm \$6.95, Fire Alarm \$6.95, Intercom \$3.95, Audio Power Amplifier \$4.95, Metronome \$3.95, Tremolo \$8.95, Light Flasher \$3.95, Electronic "Mystifier" \$4.95, Photo Cell Nite Lite \$4.95, Power Supply \$7.95, Code Oscillator \$2.50, FM Wireless Mike \$9.95, AM Wireless Mike \$9.95, Electronic VOX \$7.95, FM Radio \$9.95, AM Radio \$7.95, Electronic Bongos \$7.95.



## Citizen's Band

**Two years ahead! Model 7923**  
All Solid-State 23-Channel 5W Transceiver. 4 exclusives: dual-crystal lattice filter for razor-sharp selectivity; efficient up-converter frequency synthesizer for advanced stability; precision series-mode fundamental crystals; Small: only 3"H, 8"W, 8¼"D. \$189.95 wired only.

The best buy in tube-type CB—"Sentinel-Pro" 23-channel dual conversion 5W Transceiver \$169.95 wired only.

EICO Trans/Match (Model 715) is a professional test set designed for complete checking of ham and CB equipment. Kit \$34.95; Wired \$49.95.



## Truvohm

Professional Portable Multimeters by EICO.

The industry's greatest V-O-M values.

Designed, made to Eico's high standards of professionalism. Each complete with batteries & test leads.

Backed 100% by famous EICO warranty.

Model 100A4, 100,000Ω/V, \$34.95.

Model 30A4, 30,000Ω/V, \$19.95.

Model 30A3, 30,000Ω/V, \$15.95.

Model 20A3, 20,000Ω/V, \$12.95.

Model 4A3, 4000Ω/V, \$8.95.

Model 1A1, 1000Ω/V, \$5.95.



## Automotive

EICO 888—Car/Boat Engine Analyzer.

For all 6V/12V systems; 4, 6, 8-cyl. engines.

Now you can keep your car or boat engine in tip-top shape with this solid-state, portable, self-powered universal engine analyzer. Completely tests your total ignition/electrical system.

Complete with a Tune-up & Trouble-shooting Manual. Model 888; \$44.95 kit, \$69.95 wired.



## Test Equipment

100 best buys to choose from.

"The Professionals"  
—laboratory precision at lowest cost.

Model 460 Wideband Direct-Coupled 5" Oscilloscope. DC-4.5mc for color and B&W TV service and lab use. Push-pull DC vertical amp., bal. or unbal. input. Automatic sync limiter and amp. \$109.95 kit, \$149.95 wired.

Model 232 Peak-to-Peak VTVM. A must for color or B&W TV and industrial use. 7 non-skip ranges on all 4 functions. With exclusive Uni-Probe.® \$29.95 kit, \$49.95 wired.

FREE 1968 CATALOG

RE-12

EICO Electronic Instrument Co., Inc.  
131-01 39th Ave., Flushing, N. Y. 11352

Send me FREE catalog describing the full EICO line of 200 best buys, and name of nearest dealer.

Name \_\_\_\_\_

Address \_\_\_\_\_

City \_\_\_\_\_

State \_\_\_\_\_ Zip \_\_\_\_\_

# Yours FREE with purchase of any RCA 21" color picture tube!

In RCA's "VOLUMES OF VALUE" Program.

\*Except test tubes.

**LIFE Science Library**

SPECIAL OFFER ON



COLOR PICTURE TUBES

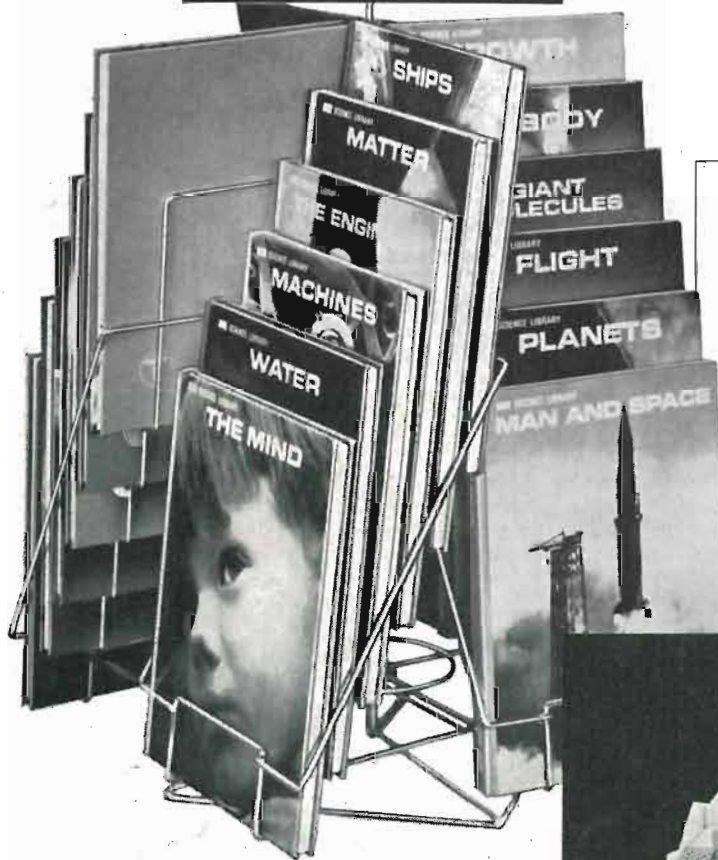

### Choice of 24 Volumes LIFE Science Library

- |          |                    |
|----------|--------------------|
| Flight   | Sound and Hearing  |
| Ships    | Health and Disease |
| Time     | Man and Space      |
| Wheels   | Giant Molecules    |
| The Cell | Drugs              |
| The Body | The Scientist      |
| The Mind | The Planets        |
| Matter   | The Engineer       |
| Energy   | The Physician      |
| Growth   | Food and Nutrition |
| Water    | Mathematics        |
| Weather  | Machines           |

### Any two LIFE Science Library books

Earn a gift that not only enriches the mind but one that will become a valued family possession. Choose from the 24 volumes of this nationally advertised library.

Each hardbound Life Science Library book comprises about 200 pages, 35,000 words of text, and hundreds of drawings, photographs, charts and diagrams, many of them in full color. Size is 8½ by 11 inches. The Library is beautifully matched and will bring to your family an ever-ready source of lively and concise information on virtually every scientific subject.

ASK YOUR AUTHORIZED RCA COLOR PICTURE TUBE DISTRIBUTOR FOR THE DETAILS! OFFER GOOD TILL JANUARY 31, 1968.

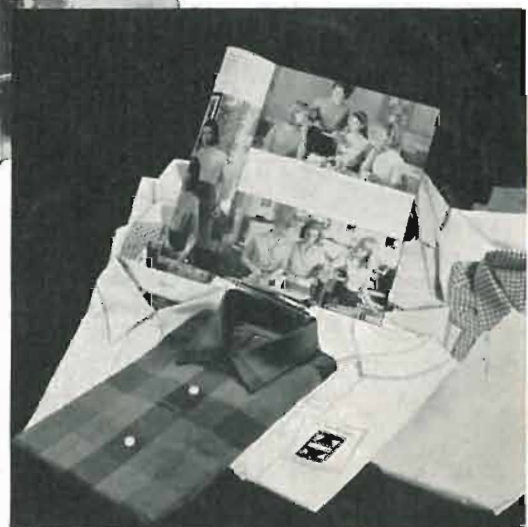

### Or your choice of a Van Heusen® shirt

A huge selection of colors and styles for both men and ladies. All are Vanopress™—the permanently pressed shirt that never needs ironing. A 20-page catalog to choose from.

RCA Electronic Components and Devices, Harrison, N. J.



The Most Trusted Name in Electronics